

Compliance Document for New Zealand Building Code Clauses C1, C2, C3, C4 Fire Safety

Prepared by the Department of Building and Housing

This Compliance Document is prepared by the Department of Building and Housing. The Department of Building and Housing is a Government Department established under the State Sector Act 1988.

Enquiries about the content of this document should be directed to:



Department of
Building and Housing
Te Tari Kaupapa Whare

Department of Building and Housing
PO Box 10-729, Wellington.
Telephone 0800 242 243
Fax 04 494 0290
Email: info@dbh.govt.nz

Compliance Documents are available from www.dbh.govt.nz

New Zealand Government

© Department of Building and Housing 2011

This Compliance Document is protected by Crown copyright, unless indicated otherwise. The Department of Building and Housing administers the copyright in this document. You may use and reproduce this document for your personal use or for the purposes of your business provided you reproduce the document accurately and not in an inappropriate or misleading context. You may not distribute this document to others or reproduce it for sale or profit.

The Department of Building and Housing owns or has licences to use all images and trademarks in this document. You must not use or reproduce images and trademarks featured in this document for any purpose (except as part of an accurate reproduction of this document) unless you first obtain the written permission of the Department of Building and Housing.

Status of Compliance Documents

Compliance Documents are prepared by the Department of Building and Housing in accordance with section 22 of the Building Act 2004. A Compliance Document is for use in establishing compliance with the New Zealand Building Code.

A person who complies with a Compliance Document will be treated as having complied with the provisions of the Building Code to which the Compliance Document relates. However, a Compliance Document is only one method of complying with the Building Code. There may be alternative ways to comply.

Users should make themselves familiar with the preface to the New Zealand Building Code Handbook, which describes the status of Compliance Documents and explains alternative methods of achieving compliance.

Defined words (italicised in the text) and classified uses are explained in Clauses A1 and A2 of the Building Code and in the Definitions at the start of this Compliance Document.

C1, C2, C3 and C4: Document History				
	Date	Alterations		
First published December 2000	Effective from 1 June 2001	This document replaces all previous editions of the individual documents C1, C2, C3 and C4.		
Errata	1 July 2001	p. 2 Document History, Status p. 29 Definitions	p. 43 Table 2.1	
Amendment 1	6 January 2002	pp. 4-7 Code Clauses C2, C3		
Amendment 2	24 April 2003	p. 201 A1.3, A2.1.1 Type 1	p. 219 Index	
Amendment 3	25 February 2004	pp. 16-17 Contents pp. 19-22 References p. 27 Definitions p. 33 VM1	pp. 193-199 Part 9 pp. 213-214, 221-223, 226-228 Index	
Amendment 4 4 July 2005	Effective 1 October 2005	p. 2 Document History, Status p.13 Contents pp. 19-20 References pp. 23-29, 31-32 Definitions p. 43 Table 2.1 p. 58 3.5.4 p. 73 3.15.3 p. 89 3.18.1 p. 98 4.5.8 p. 99 4.5.19-4.5.22	pp. 101-106 Table 4.1 p. 108 5.3.1, 5.3.2 pp. 109-11 5.6.2-5.6.13 p. 116 5.9.4 p. 119 6.2.1 p. 120 6.5-6.6.2 p. 121 6.6.4, 6.6.7, 6.7.2 p. 122 6.7.5, 6.7.6, 6.7.9 p. 123 6.9.2 p. 125 6.10.2	p. 127 6.11.1 p. 131 6.14.3 pp. 133-5 6.16.2-6.16.7 p. 142 6.19.13 p. 145 6.20.16 p. 175 7.9.3 p. 176 7.9.8 pp. 179-180 7.10.2-7.10.8 pp. 210-212 Appendix D pp. 213-215, 217-221, 224, 225, 227, 228, Index
Reprinted incorporating Amendment 4	July 2005			
Amendment 5 1 October 2005	1 October 2005	p. 2 Document History p.19 References p. 37 1.3.6 pp. 40-41 2.2.2, 2.2.10 p. 43 Table 2.1 p. 96 4.3.2 p. 98 4.5.5, 4.5.7 p. 100 Comment	p. 101-4 Table 4.1 p. 107-113 5.1.1, 5.2.1, 5.3.2, 5.3.3, 5.6.1, 5.6.4, 5.6.5, 5.6.8, 5.6.11, 5.7.9 p. 119 6.1.1, 6.6.3 p. 122 6.7.5 p. 123 6.8.5 p. 126 6.10.2	p. 127 6.11.2 p. 143 6.19.14 p. 150 6.22.12 p. 152 6.23.4 p. 153-154 Table 6.1, 6.2 p. 179 7.10.2, 7.10.8 p. 181-182 Tables 7.1, 7.2 p. 188-190 Tables 7.3-7.5
Amendment 6	Effective 21 June 2007	pp. 2-2A Document History	p. 5 Code Clause C2	

C1, C2, C3 and C4: Document History (continued)

	Date	Alterations		
Amendment 7	Effective 1 November 2008	pp. 2-2A Document History p. 5 Code Clause C2 p.17 Contents pp. 19-21 References pp. 29-32 Definitions p. 41 2.3.7 p. 43 Table 2.1 p. 81 3.17.1, 3.17.3 p. 89 3.17.15, 3.17.16 p. 96 4.2.4 Comment, 4.2.5 p. 97 4.5.4 p. 98 4.5.10, 4.5.11 p. 101 Table 4.1	p. 102 Table 4.1/1 p. 103 Table 4.1/2 p. 104 Table 4.1/3 p. 105 Table 4.1/4 p. 106 Table 4.1/5 p. 110 5.6.6 p. 111 5.6.13 p. 121 6.6.4, 6.7.1 p. 122 6.8.1 Comment p. 127 6.11.4 p. 141 6.19.7 p. 145 6.20.16, 6.20.17 p. 147 6.21.6	p. 149 6.22.6 p. 154 Table 6.2 p. 159 7.2.2 p. 173 7.8.5, Comment p. 180 7.11.2 pp. 201-203 Appendix A p. 205 Appendix B pp. 207-209 Appendix C p. 210 Appendix D pp. 213, 214, 218-221, 227, 228 Index
Amendment 8	Published 30 June 2010 Effective from 30 September 2010	p. 2A, Document History, Status p. 8, Code Clause C3 p. 19, References	p. 140, C/AS1 6.18.10 p. 210, Appendices D 1.1.2	
Amendment 9	Effective 10 October 2011	p. 2A, Document History, Status pp. 19-22, References p. 81, C/AS1 3.17.2	p. 115, C/AS1 5.18.10 p. 141, C/AS1 6.19.7 p. 208, Appendices C 7.1.1	

Note: Page numbers relate to the document at the time of Amendment and may not match page numbers in current document.

Document Status

The most recent version of this document, as detailed in the Document History, is approved by the Chief Executive of the Department of Building and Housing. It is effective from 10 October 2011 and supersedes all previous versions of this document.

People using this Compliance Document should check for amendments on a regular basis. The Department of Building and Housing may amend any part of any Compliance Document at any time. Up-to-date versions of Compliance Documents are available from www.dbh.govt.nz

New Zealand Building Code Fire Safety Clauses

The mandatory provisions for building work are contained in the New Zealand Building Code (NZBC), which comprises the First Schedule to the Building Regulations 1992. The relevant NZBC Clauses for Fire Safety in buildings are C1, C2, C3 and C4.

1992/150	<i>Building Regulations 1992</i>	21
FIRST SCHEDULE—continued		
Clause C1—OUTBREAK OF FIRE		
Provisions	Limits on application	
OBJECTIVE		
C1.1 The objective of this provision is to safeguard people from injury or illness caused by <i>fire</i> .		
FUNCTIONAL REQUIREMENT		
C1.2 In <i>buildings</i> fixed appliances using the controlled combustion of solid, liquid or gaseous fuel, shall be installed in a way which reduces the likelihood of <i>fire</i> .		
PERFORMANCE		
C1.3.1 Fixed appliances and services shall be installed so as to avoid the accumulation of gases within the installation and in <i>building</i> spaces, where heat or ignition could cause uncontrolled combustion or explosion.		
C1.3.2 Fixed appliances shall be installed in a manner that does not raise the temperature of any <i>building element</i> by heat transfer or concentration to a level that would adversely affect its physical or mechanical properties or function.		

FIRST SCHEDULE—*continued*

Clause C2—MEANS OF ESCAPE

Provisions

Limits on application

OBJECTIVE

C2.1 The objective of this provision is to:

- (a) Safeguard people from injury or illness from a *fire* while escaping to a *safe place*, and
- (b) Facilitate *fire* rescue operations.

FUNCTIONAL REQUIREMENT

C2.2 *Buildings* shall be provided with *means of escape from fire* which:

- (a) Give people *adequate* time to reach a *safe place* without being overcome by the effects of *fire*, and
- (b) Give fire service personnel *adequate* time to undertake rescue operations.

PERFORMANCE

C2.3.1 The number of *open paths* available to each person escaping to an *exitway* or *final exit* shall be appropriate to:

- (a) The *travel distance*.
- (b) The number of occupants,
- (c) The *fire hazard*, and
- (d) The *fire safety systems* installed in the *firecell*.

C2.3.2 The number of *exitways* or *final exits* available to each person shall be appropriate to:

- (a) The *open path travel distance*,
- (b) The *building height*,
- (c) The number of occupants,
- (d) The *fire hazard*, and
- (e) The *fire safety systems* installed in the *building*.

C2.3.3 *Escape routes* shall be:

- (a) Of *adequate* size for the number of occupants,

Amend 1
Jan 2002

FIRST SCHEDULE—continued

Provisions

- (b) Free of obstruction in the direction of escape,

- (c) Of length appropriate to the mobility of the people using them,
- (d) Resistant to the spread of *fire* as required by Clause C3 “Spread of Fire”,
- (e) Easy to find as required by Clause F8 “Signs”,
- (f) Provided with systems for visibility during failure of the main lighting, as required by Clause F6 “Visibility in escape routes”, and
- (g) Easy and safe to use as required by Clause D1.3.3 “Access Routes”.

Limits on application

Performance C2.3.3(b) must not prevent a door that forms part of an *escape route* from being locked if the person who locks it is satisfied that no-one is in that part of the *building* served by the *escape route* and that no one is likely to enter that part of the *building*, except in an emergency, without unlocking that door.

Amend 1
Jan 2002

Amend 7
Nov 2008

FIRST SCHEDULE—*continued*

Clause C3—SPREAD OF FIRE

Provisions

OBJECTIVE

C3.1 The objective of this provision is to:

- (a) Safeguard people from injury or illness when evacuating a *building* during *fire*.
- (b) Provide protection to fire service personnel during firefighting operations.
- (c) Protect adjacent *household units*, other residential units, and *other property* from the effects of *fire*.
- (d) Safeguard the environment from adverse effects of *fire*.

FUNCTIONAL REQUIREMENT

C3.2 *Buildings* shall be provided with safeguards against *fire* spread so that:

- (a) Occupants have time to escape to a *safe place* without being overcome by the effects of *fire*,
- (b) Firefighters may undertake rescue operations and protect property,
- (c) Adjacent *household units*, other residential units, and *other property* are protected from damage, and
- (d) Significant quantities of *hazardous substances* are not released into the environment during *fire*.

PERFORMANCE

C3.3.1 Interior surface finishes on walls, floors, ceilings and suspended *building elements*, shall resist the spread of *fire* and limit the generation of toxic gases, smoke and heat, to a degree appropriate to:

- (a) The *travel distance*,
- (b) The number of occupants,

Limits on application

Requirement C3.2(d) applies only to *buildings* where significant quantities of *hazardous substances* are stored and processed.

Amend 1
Jan 2002

Amend 1
Jan 2002

FIRST SCHEDULE—continued

Provisions

- (c) The *fire hazard*, and
 - (d) The active *fire safety systems* installed in the *building*.
- C3.3.2** *Fire separations* shall be provided within *buildings* to avoid the spread of *fire* and smoke to:
- (a) Other *firecells*,
 - (b) Spaces intended for sleeping, and
- (c) *Household units* within the same *building* or *adjacent buildings*.
 - (d) *Other property*.
- C3.3.3** *Fire separations* shall:
- (a) Where openings occur, be provided with *fire resisting closures* to maintain the *integrity* of the *fire separations* for an *adequate* time, and
 - (b) Where penetrations occur, maintain the *fire resistance rating* of the *fire separation*.
- C3.3.4** *Concealed spaces* and cavities within *buildings* shall be sealed and subdivided where necessary to inhibit the unseen spread of *fire* and smoke.
- C3.3.5** *External walls* and roofs shall have resistance to the spread of *fire*, appropriate to the *fire load* within the *building* and to the proximity of other *household units*, other residential units and *other property*.
- C3.3.6** Automatic *fire* suppression systems shall be installed where people would otherwise be:
- (a) Unlikely to reach a safe place in *adequate* time because of the number of storeys in the *building*,
 - (b) Required to remain within the *building* without proceeding directly to a *final exit*, or where the *evacuation time* is excessive,

Limits on application

Performance C3.3.2(b) does not apply to *Detached Dwellings* or within *household units* of *Multi-unit Dwellings*.

Performance C3.3.4 shall not apply to *Detached Dwellings*.

Amend 1
Jan 2002

Amend 1
Jan 2002

FIRST SCHEDULE—*continued*

Provisions

- (c) Unlikely to reach a *safe place* due to confinement under institutional care because of mental or physical disability, illness or legal detention, and the *evacuation time* is excessive, or
- (d) At high risk due to the *fire load* and *fire hazard* within the *building*.

C3.3.7 Air conditioning and mechanical ventilation systems shall be constructed to avoid circulation of smoke and *fire* between *firecells*.

C3.3.8 Where an automatic smoke control system is installed, it shall be constructed to:

- (a) Avoid the spread of *fire* and smoke between *firecells*, and
- (b) Protect *escape routes* from smoke until the occupants have reached a *safe place*.

C3.3.9 The *fire safety systems* installed shall facilitate the specific needs of fire service personnel to:

- (a) Carry out rescue operations, and
- (b) Control the spread of *fire*.

C3.3.10 Environmental protection systems shall ensure a low probability of *hazardous substances* being released to:

- (a) Soils, vegetation or natural waters,
- (b) The atmosphere, and
- (c) *Sewers* or public *drains*.

Limits on application

Performance C3.3.9 does not apply to *backcountry huts*.

Performance C3.3.10 applies only to *buildings* where significant quantities of *hazardous substances* are stored or processed.

Amended
31 Oct 2008

1992/150

Building Regulations 1992

27

FIRST SCHEDULE—*continued*

Clause C4—STRUCTURAL STABILITY DURING FIRE

Provisions	Limits on application
OBJECTIVE	
C4.1 The objective of this provision is to:	
<ul style="list-style-type: none"> (a) Safeguard people from injury due to loss of structural stability during <i>fire</i>, and (b) Protect <i>household units</i> and other <i>property</i> from damage due to structural instability caused by <i>fire</i>. 	
FUNCTIONAL REQUIREMENT	
C4.2 <i>Buildings</i> shall be constructed to maintain structural stability during <i>fire</i> to:	
<ul style="list-style-type: none"> (a) Allow people <i>adequate</i> time to evacuate safely, (b) Allow fire service personnel <i>adequate</i> time to undertake rescue and firefighting operations, and (c) Avoid collapse and consequential damage to adjacent <i>household units</i> or other <i>property</i>. 	
PERFORMANCE	
C4.3.1 Structural elements of <i>buildings</i> shall have <i>fire</i> resistance appropriate to the function of the elements, the <i>fire load</i> , the <i>fire intensity</i> , the <i>fire hazard</i> , the height of the <i>buildings</i> and the <i>fire</i> control facilities external to and within them.	
C4.3.2 Structural elements shall have a <i>fire</i> resistance of no less than that of any element to which they provide support within the same <i>firecell</i> .	
C4.3.3 Collapse of elements having lesser <i>fire</i> resistance shall not cause the consequential collapse of elements required to have a higher <i>fire</i> resistance.	

Contents

	Page		Page
References	19	2.4 Residential Community Care	42
Definitions	23	<i>Table 2.1</i> Purpose groups	43
Verification Method C/VM1	33	<i>Table 2.2</i> Occupant densities	45
1.1 Solid Fuel Appliances	33	Part 3: Means of Escape	47
Limiting heat transfer	33	3.1 General Principles	47
Acceptable Solution C/AS1	35	Advantages of FSPs	48
Part 1: Introduction	35	3.2 Number of Escape Routes	48
1.1 Scope	35	3.3 Height and Width of Escape Routes	49
Defined terms and comments	35	Height	49
Reference documents	35	Width	49
Tables	35	Handrails and limitations to stair widths	51
1.2 Using this Document	35	Curved and spiral stairs	52
1.3 Recommended Design Sequence	36	Obstructions	52
General approach	36	Accessible escape routes	53
Detached dwellings	36	3.4 Length of Escape Routes	53
Multi-unit dwellings	37	Open paths	53
Part 2: Occupant Numbers and Purpose Groups	39	Protected paths	54
2.1 General	39	Protected path floor area	55
2.2 Purpose Groups and Fire Hazard Categories	39	Intermediate floors	56
Primary purpose group for multiple activities	40	Stairs and ladders	57
Purpose groups CS and CL	40	Sloping floors and ceilings	58
Purpose group SH	40	3.5 Acceptable Increases in Open Path Lengths	58
Purpose group SA treated as SR or SH	40	Sprinklers	58
Fire hazard category 4	40	Heat detectors	58
2.3 Occupant Load	41	Smoke detectors	58
Fixed seating	41	Combination of increases	59
Where occupancy is based on number of beds	41	3.6 Escape through Adjoining Building	59
Justification for exceptions	41	3.7 Escape from Basements	59
		3.8 Open Paths	59
		Number and size	59
		Open path separation	60
		Exception for education buildings	61

	Page		Page
3.9 Special Cases of Open Paths	61	3.16 Special Conditions for Crowd and Sleeping Purpose Groups	79
Separate tenancy	61	Purpose group CL	79
Ramps	61	Exitways from upper and intermediate floors in purpose group CL	79
Fixed seating	62	Final exit separation	80
Aisles	63	Open air auditoriums, purpose group CO	80
Loose seating	64	Purpose groups SC, SD, SA and SR	80
Passing into an adjacent firecell	65	3.17 Doors Subdividing Escape Routes	80
Escape via an intermediate floor	66	Door closers and latching	80
Open paths via unenclosed stairs	66	Locking devices	81
3.10 Dead Ends	66	Direction of opening	81
No more than 50 occupants	66	Degree and width of opening	82
Ladders	66	Vision panels	83
3.11 Exitways	66	Revolving doors, automatic doors and access control systems	83
Protected paths	66	Hold-open devices	83
Safe paths	67	Delayed action unlocking devices	83
Safe path length restrictions	67	Smoke control doors	85
Safe path termination	67	Fire doors	86
Safe path separation, glazing and smoke control	67	Panic bolts	89
3.12 Control of Exitway Activities	67	3.18 Windows Used for Escape	89
Lifts	68	Application	89
3.13 Refuge Areas	68	Obstruction to be avoided	90
3.14 External Escape Routes	69	Size	90
Separation by distance	69	Sill height	90
Separation by fire rated construction	70	Latching	90
Ventilation openings	71	Escape capacity	90
Barriers	71	3.19 Lighting	90
3.15 Single Escape Routes	71	Artificial lighting	90
Basements	72	Lighting for emergency	90
Active purpose groups	73		
Sleeping purpose groups SR and SA	73		
Internal stairways	76		
Balconies, bridges and external stairways	76		
Split level exitway	76		

		Page			Page
3.20	Signs	90	5.4	Essential Data for Determining F and S Ratings	108
	<i>Table 3.1</i> Number of escape routes from a floor level	91	5.5	Determining F and S Ratings	109
	<i>Table 3.2</i> Width of escape routes	92		F ratings	109
	<i>Table 3.3</i> Lengths of open paths and protected paths	93		S ratings for firecells with FHC 1, 2 and 3	109
	<i>Table 3.4</i> Walkways in fixed seating	93	5.6	Determining the FRR	109
	Part 4: Requirements for Firecells	95		Applying insulation component in FRR	110
4.1	General Principles	95		FRR reductions for sprinklered firecells	110
4.2	Provision of Firecells	95		Concessions for multiple purpose groups	110
	Number of firecells	95		Special requirements for buildings remaining occupied during fire	110
	Firecell floor area limits	96		Firecells with FHC 4	111
	Fire safety precautions for firecells	96	5.7	Applying FRRs to Building Elements	111
	Assessing FSP requirements	96		General requirements	111
4.3	Table 4.1	96		Minimum FRRs	112
	Limitations of table	96	5.8	Glazing in Fire and Smoke Separations	113
	Purpose groups SH, CO, IE, IA, ID	96		Fire separations	113
4.4	Using Table 4.1	97		Safe paths	113
4.5	Determining FSPs for Whole Building	97		Concession for sprinklers	115
	More than one purpose group on a floor	97		Smoke separations	115
	F ratings	98		Fire doors and smoke control doors	115
	Other floors in a building	98	5.9	Structural Stability During Fire	115
	Same purpose group on different floors	98		Primary element loadings	115
	Top floor firecells	98		Unrated primary elements	116
	Basements	99		Providing stability	117
	Intermediate floors	99		Fire resistance tests	117
	Early childhood centres	99		<i>Table 5.1</i> Values of t_e for calculating the S ratings for fire hazard categories 1, 2 and 3	118
	Specific requirements	99			
	<i>Table 4.1</i> Fire safety precautions	101			
Part 5:	Fire Resistance Ratings	107			
5.1	FRR Components	107			
5.2	FRR Component Values	107			
5.3	Application of F and S Ratings	108			
	F ratings	108			
	S ratings	108			

Amend 4
Oct 2005 |

Amend 4
Oct 2005 |

	Page		Page
Part 6: Control of Internal Fire and Smoke Spread	119	6.13 Long Corridor Subdivision	130
6.1 General	119	6.14 Floors	131
6.2 Firecells Rated F0	119	Intermediate floors	131
6.3 Purpose Groups CS and CL	119	Basement floors	132
Theatres	119	6.15 Subfloor Spaces	132
Theatre stages	119	6.16 Protected Shafts	133
6.4 Purpose Group CM	120	Lifts, conveyors and services	133
6.5 Purpose Group CO	120	Fire separation	133
6.6 Purpose Groups SC and SD	120	Openings in protected shafts	134
Group sleeping areas	120	Solid waste and linen chutes	135
Suites	121	Sprinklers in protected shafts	135
Special care facilities	121	6.17 Fire Stopping	135
Support and service functions	121	Introduction	135
6.7 Purpose Group SA	121	Fire stops	135
Group sleeping areas	121	Installation	135
Suites	122	Service outlets	135
Halls and wharehousi	122	Penetrations to be supported	136
6.8 Purpose Groups SR and SH	122	6.18 Concealed Spaces	136
6.9 Purpose Group IE	123	Concealed spaces within firecells	136
Ventilation in enclosed exitways for purpose groups SC, SD, SR and SA	123	Cavity barriers in walls and floors	138
Vertical safe path smoke control	124	Exceptions	139
6.10 Purpose Group IA	124	Cavity barrier construction	139
Support activities	124	Restriction of roof and ceiling space areas in unsprinklered firecells	140
Solid waste storage	125	Sprinklered firecells	140
Car parking	125	6.19 Closures in Fire and Smoke Separations	140
6.11 Purpose Group ID	127	Introduction	140
Plant, boiler and incinerator rooms	127	Fire door and smoke control door installation	141
6.12 Firecell Construction	127	Doorset markings	141
Junctions of fire separations	128	Glazing in doors	141
Junctions with roof	128	Theatre proscenium walls	141
Ceiling space firecells	130	Protected shaft access panels	142
Sealing of gaps	130	Lift landing doors	142
		Fire dampers	143
		Fire shutters	143

		Page			Page
6.20	Interior Surface Finishes, Floor Coverings and Suspended Flexible Fabrics	143			
	General principles	143		Table 6.1 Closures in fire and smoke separations	153
	Exceptions	143		Table 6.2 Requirements for interior surface finishes and suspended flexible fabrics to inhibit fire spread	154
	Sprinklers and foamed plastics	144		Table 6.3 Foamed plastics – protection from ignition	155
	Trampers’ huts	144		Table 6.4 Volumes of unvented smoke reservoirs for limited area atrium firecells	155
	CS and CL purpose groups	144		Table 6.5 Natural smoke ventilation of firecells with intermediate floors	156
	Flooring	144		Table 6.6 Mechanical smoke extraction of firecells with intermediate floors	156
	Foamed plastics building materials	144			
	Flame barriers	145			
	Wood and wood products in floors	145			
	Wood and wood products in walls and ceilings	145			
	Suspended flexible fabrics	145			
	Membrane structures	145			
	Air-supported structures	145			
	Air ducts	146			
6.21	Smoke Control	146		Part 7: Control of External Fire Spread	157
	Exitways – natural ventilation	146		7.1 General Principles	157
	Exitways – pressurisation	146		7.2 Separation of Legal Titles	159
	Firecells with intermediate floors	146		7.3 Horizontal Fire Spread from External Walls	159
	Firecells with limited area intermediate floors	147		Firecell separation	159
				Choosing calculation method	160
				Check other external walls	160
				Sprinklered firecells	160
				Notional boundary – firecells on the same property	162
				Important considerations when using tables	162
6.22	Limited Area Atrium Firecells	147		7.4 Method 1 – Small Openings and Fire Resisting Glazing	163
	Atrium dimensions	149		Size and spacing of Type A and Type B areas	163
	Sprinkler systems	149			
	Atrium smoke control methods	149		7.5 Method 2 – Enclosing Rectangles – Parallel Boundary	163
	Smoke reservoirs	149		Advantages of additional firecells	165
	Natural smoke ventilation	150		Exceptions for SH, SA and SR buildings	165
	Mechanical smoke extract	150		Buildings on sloping sites and buildings of irregular height	168
	Inlet vents and smoke vents	151			
6.23	Building Services Plant	151			
	Automatic activation	151			
	Air-handling systems	151			
	Emergency power supply	152			

	Page		Page
7.6 Method 3 – Enclosing Rectangles – Irregular Buildings and Non-parallel Boundaries	169	7.11 Exterior Surface Finishes	180
		Roofs	180
7.7 Method 4 – Return Walls and Wing Walls	169	External walls	180
Other property or same property	169	Purpose group SH	181
Return walls	169	Table 7.1 Method 1 – permitted areas of fire resisting glazing	181
Wing walls	169	Table 7.2 Method 2 – enclosing rectangles permitted unprotected areas in unsprinklered buildings	182
Using Table 7.3 and Table 7.4	170	Table 7.3 Method 4 – return walls and wing walls for unsprinklered firecells. Protection of other property	188
Sprinklered firecells	172	Table 7.4 Method 4 – return walls and wing walls for unsprinklered firecells. Protection of sleeping purpose groups or safe paths on the same property	189
Intersection angles of between 90° and 135°	172	Table 7.5 Acceptable heat release rates for external wall cladding systems	190
7.8 Horizontal Fire Spread from Roofs, Floors and Open Sided Buildings	172	Part 8: Fire Fighting	191
Parapets for roof car parking or storage	173	8.1 Fire Service Vehicular Access	191
Roof projections	173	Special provisions for SC and SD purpose groups	191
Floor projections	173	8.2 Fire Fighting Facilities	191
Balconies	173	Fire hydrant system	191
Open sided buildings	173	Fire hose reels	191
7.9 Vertical Fire Spread	175	Fire systems centre	191
Roofs	175	Fire Service lift control	192
External exitways over roofs	175	Voice communication system	192
Primary elements	175	Part 9: Outbreak of Fire	193
Fire spread from an adjacent lower roof	175	9.1 Solid Fuel Appliances	193
External fire spread between different levels of the same building	176	Modification to AS/NZS 2918	193
Roof car parking and storage	177	9.2 Gas Burning Appliances	193
External thermal insulation on walls in multi-storey buildings	177	Modifications to NZS 5261	193
7.10 FRRs of External Walls	179	9.3 Oil Fired Appliances	193
External walls adjacent to external escape routes	179	Modification to AS 1691	193
Return walls and wing walls	179		
Small buildings	179		
Purpose groups SH and SR	180		

Amend 3
Feb 2004

Amend 3
Feb 2004

	Page		Page
9.4 Down Lights	194	Appendix D: Fire Sprinkler Systems	210
9.5 Open Fires	194	D1.1 Introduction	210
<i>Table 9.1</i> Chimneys – minimum acceptable dimensions	199	D2.1 Automatic Fire Sprinkler Systems	210
Appendix A: Fire Safety Precautions	201	D3.1 Residential Fire Sprinkler Systems	211
A1.1 Types of FSP	201	Index	213
A1.2 Fire Alarm and Sprinkler Systems	201		
A1.3 Requirements Common to All Alarm Systems	201		
A2.1 FSP Descriptions	201		
Appendix B: Testing of Smoke Control Systems	205		
B1.1 General	205		
B2.1 Pre-occupancy Test	205		
B3.1 Annual Testing	206		
B4.1 Small Firecells	206		
Appendix C: Test Methods	207		
C1.1 General	207		
C2.1 Flammability of Floor Coverings	207		
C3.1 Flammability of Suspended Flexible Fabrics and Membrane structures	207		
C4.1 Properties of Lining Materials	207		
C5.1 Non-combustibility of Materials	207		
C6.1 Fire Resistance	207		
C7.1 Fire Resisting Closures and Smoke Control Doors	208		
Frictional forces	208		
Self-closing provision	208		
Automatic smoke-sensing devices	208		
C8.1 Fire Properties of External Wall Cladding Systems	208		
C9.1 Flame Barriers	209		

Amend 7
Nov 2008

References

For the purposes of New Zealand Building Code (NZBC) compliance, the Standards and documents referenced in this Compliance Document (primary reference documents) must be the editions, along with their specific amendments, listed below. Where these primary reference documents refer to other Standards or documents (secondary reference documents), which in turn may also refer to other Standards or documents, and so on (lower-order reference documents), then the version in effect at the date of publication of this Compliance Document must be used.

Amend 9
Oct 2011

Where quoted

(Unless otherwise stated all references apply to **C/AS1**)

Standards New Zealand

Amend 7
Nov 2008

NZS 4232:-
Part 2: 1988 Performance criteria for fire resisting closures
Fire resisting glazing systems

5.8.3 a), 5.8.4,
Figure 5.1

Amend 7
Nov 2008

NZS 4503: 2005 Hand operated fire fighting equipment

A2.1 (Type 14)

Amend 8
Sep 2010

NZS 4510: 2008 Fire hydrant systems for buildings
Amend: 1

A2.1 (Type 18)

NZS 4512: 2010 Fire detection and alarm systems in buildings

6.22.14 b) i),
A2.1 (Type 9), C7.1.6

Amend 4
Oct 2005

NZS 4515: 2009 Fire sprinkler systems for life safety in sleeping occupancies (up to 2000 m²)

6.16.7, 6.18.10,
D3.1.1, Table 7.5

Amend 9
Oct 2011

NZS 4520: 2010 Fire resistant doorsets

5.8.1.0, 6.19.7
C7.1.1

Amends
4 and 7
Amend 8
Sep 2010

NZS 4541: 2007 Automatic fire sprinkler systems
Amend: 1

6.16.7, 6.18.10,
6.19.9, 6.22.6, D2.1.1,
Table 7.5

Amend 3
Feb 2004
Amend 7
Nov 2008

NZS 5261: 2003 Gas installation
Amend: 1, 2

9.2.1, 9.2.2

NZS 6104: 1981 Specification for emergency electricity supply in buildings

6.23.3

Amend 3
Feb 2004

NZS/BS 476:-
Part 20: 1987 Fire tests on building materials and structures
Method for determination of the fire resistance of elements of construction (general principles)
Amend: 6587

C6.1.1

Part 21: 1987 Methods for determination of the fire resistance of loadbearing elements of construction

C6.1.1

Part 22: 1987 Methods for determination of the fire resistance of non-loadbearing elements of construction

C6.1.1

Amend 7
Nov 2008

Amend 5
Oct 2005

Amend 5
Oct 2005

Amend 7
Nov 2008

Standards Australia

AS 1366:-	Rigid cellular plastics sheets for thermal insulation
Part 1: 1992	Rigid cellular polyurethane (RC/PUR) <i>Amend: 1</i>
Part 2: 1992	Rigid cellular polyisocyanurate (RC/PIR)
Part 3: 1992	Rigid cellular polystyrene – Moulded (RC/PS-M) <i>Amend: 1</i>
Part 4: 1989	Rigid cellular polystyrene – Extruded (RC/PS-E)
AS 1530:-	Methods for fire tests on building materials, components and structures
Part 1: 1994	Combustibility test for materials
Part 2: 1993	Test for flammability of materials
Amend 9 Oct 2011 Part 4: 2005	Fire-resistance tests of elements of construction
Amend 3 Feb 2004 AS 1691: 1985	Domestic oil-fired appliances – installation
AS 2220:-	Emergency warning and intercommunication systems in buildings
Part 1: 1989	Equipment design and manufacture
Part 2: 1989	System design, installation and commissioning
AS 4072:-	Components for the protection of openings in fire-resistant separating elements
Amend 9 Oct 2011 Part 1: 2005	Service penetrations and control joints

Joint Australian/New Zealand Standards

AS/NZS 1170:-	Structural Design Actions
Part 0: 2002	General principles
Amend 7 Nov 2008 AS/NZS 1221: 1997	Fire Hose Reels <i>Amend: 1</i>
AS/NZS 1530:-	Methods for fire tests on building materials, components and structures
Part 3: 1999	Simultaneous determination of ignitability, flame propagation, heat release and smoke release
AS/NZS 1668:-	The use of ventilation and air conditioning in buildings
Part 1: 1998	Fire and smoke control in multi-compartment buildings
Amend 9 Oct 2011 AS/NZS 2918: 2001	Domestic solid fuel burning appliances – installation
Amend 3 Feb 2004 AS/NZS 3837: 1998	Method of test for heat and smoke release rates for materials and products using an oxygen consumption calorimeter

Where quoted

(Unless otherwise stated all references apply to **C/AS1**)

Table 6.3	
	Amend 7 Nov 2008
C5.1.1	
C3.1.1, C4.1.1	Amend 7 Nov 2008
C6.1.1	
9.3.1, 9.3.2	
A2.1 (Type 8)	
A2.1 (Type 8)	
C6.1.2 b)	Amend 7 Nov 2008
A2.1 (Type 14)	
C4.1.1	Amend 7 Nov 2008
3.7.1 b), 6.9.6, 6.21.2, A2.1 (Type 9), A2.1 (Type 13)	
9.1.1, 9.1.2, 9.3.3, 9.5.6, 9.5.11	
Comment	
C8.1.1, C8.1.2, Table 7.5	Amend 7 Nov 2008

References

British Standards Institution

- BS 4790: 1996 Method for determination of the effects of a small source of ignition on textile floor coverings (hot metal nut method)
- BS 5287: 1996 Specification for assessment and labelling of textile floor coverings tested to BS 4790

Where quoted

(Unless otherwise stated all references apply to **C/AS1**)

6.20.8, C2.1.1

6.20.8, C2.1.1

Amend 3
Feb 2004

Amend 7
Nov 2008

European Committee for Standardisation

- Eurocode DD ENV 1991-2-2: 1996
- Eurocode 1 Basis of design actions on structures
- Part 2.2 Actions on structures exposed to fire

Table 5.1 note 7

Building Research Establishment (UK)

- BRE Defect action sheet DAS 131: May 1989
- External walls: Combustible external plastics insulation: Horizontal fire barriers
- BRE Report 135: 1988
- Fire performance of external thermal insulation for walls in multi-storey buildings. Rogowski B.F., Ramaprasad R., Southern J.R.
- BRE Report 186: 1990
- Design principles for smoke ventilation in enclosed shopping centres. Morgan and Gardner
- BRE Report 258: 1992
- Design approaches for smoke control in atrium buildings. Hansell and Morgan

7.9.19 Comment 1

7.9.19 Comment 1

6.21.3 Comment 6

6.21.3 Comment 6,
6.21.4 Comment 2

National Fire Protection Association of America

NFPA 92B: 1995 Guide for smoke management systems in malls, atria and large areas

NFPA 285: 1998 Standard method of test for the evaluation of flammability characteristics of exterior non load bearing wall assemblies containing components using the intermediate scale, multi-storey test apparatus

American Society of Heating, Refrigeration and Air Conditioning Engineers (ASHRAE)

Design of smoke management systems. Klote and Milke 1992

International Conference of Building Officials: America

Uniform Building Code Standard 4.1: 1997
Proscenium fire safety curtains

Uniform Building Code Standard 26.2: 1997
Test method for the evaluation of thermal barriers

New Zealand Government

Amend 9 | Fire Safety and Evacuation of Buildings Regulations 2006
Oct 2011

Building Control Commission, State of Victoria, Australia

Smoke management in large spaces in buildings: 1998. Milke and Klote

New Zealand Electrical Code of Practice

Amend 3 | NZECP 54: 2001 Code of practice for the installation of recessed
Feb 2004 luminaries and auxiliary equipment

Where quoted

(Unless otherwise stated all references apply to **C/AS1**)

Table 2.1 note 1,
5.6.12 Comment 1,
6.21.3 Comment 6
7.11.2 b)

6.21.3 Comment 6

6.19.9 Comment 2

C9.1.3

Amend 7
Nov 2008

3.17.2 Comment 2

6.21.3 Comment 6

9.4.1

Definitions

The full list of definitions for italicised words may be found in the New Zealand Building Code Handbook.

- Amend 4
Oct 2005

Access route A continuous route that permits people and goods to move between the apron or *construction edge* of the *building* to spaces within a *building*, and between spaces within a *building*.
 - Amend 4
Oct 2005

Accessible Having features to permit use by a *person with a disability*.
 - Amend 4
Oct 2005

Accessible route An *access route* usable by a *person with a disability*. It shall be a continuous route that can be negotiated unaided by a wheelchair user. The route shall extend from street boundary or car parking area to those spaces within the *building* required to be *accessible* to enable a *person with a disability* to carry out normal activities and processes within the *building*.
 - Amend 4
Oct 2005

Accessible stairway A *stairway* having features for use by a *person with a disability*. *Buildings* required to be *accessible* shall have at least one *accessible stairway* leading off an *accessible route* whether or not a lift is provided.
 - Adequate** *Adequate* to achieve the objectives of the *building code*.
 - Adjacent building** A nearby *building*, including an adjoining *building*, whether or not erected on *other property*.
 - Amend 4
Oct 2005

Allotment has the meaning ascribed to it by section 10 of the Building Act 2004.
 - Alter**, in relation to a *building*, includes to rebuild, re-erect, repair, enlarge and extend; and **alteration** has a corresponding meaning.
 - Appliance hearth** A layer of *non-combustible* material under or near an appliance. It may be either part of the *building* structure or an overlay on a *combustible* floor.
 - Backflow** A flowing back or reversal of the normal direction of the flow caused by *back pressure* and includes *back-siphonage*.
 - Backflow prevention device** A device that prevents *backflow*.
 - Basement** Any *firecell* or part of a *firecell* below the level of the lowest *final exit*.
- COMMENT:**
Because *fire safety precautions* are increased with increases in *escape height*, the precautions for *basements* increase with *basement* depth. Thus a single floor *building* with one *basement* level is treated as a two floor *building*, a single floor *building* with three *basement* levels as a four floor *building*, and the requirements of Table 4.1 shall be applied downwards as opposed to upwards for levels above ground.
- Boundary** means any *boundary* which is shown on a survey plan approved by the Chief Surveyor and which is deposited in the Titles Office whether or not a new title has been issued.
 - Building** has the meaning ascribed to it by sections 8 and 9 of the Building Act 2004.
 - Building code** means the regulations made under section 400 of the Building Act 2004.
 - Building consent** means a consent to carry out *building* work granted by a *building consent authority* under section 49 of the Building Act 2004.
 - Building consent authority** has the meaning ascribed to it by section 7 of the Building Act 2004.
 - Building element** Any structural and non-structural component or assembly incorporated into or associated with a *building*. Included are *fixtures*, services, *drains*, permanent mechanical installations for access, glazing, partitions, ceilings and temporary supports.
 - Building height** The vertical distance between the floor level of the lowest *final exit* from the *building*; and the highest occupied floor level containing or supporting any *purpose group* other than IE, IA or ID, or penthouses used to enclose *stairways*, liftshafts or machinery rooms located on or within the roof.
 - Cavity barrier** A *construction* provided to close openings within a *concealed space* against the passage of *fire*, or to restrict the spread of *fire* within such spaces.

Chimney A *non-combustible* structure which encloses one or more *flues*, *fireplaces* or other heating appliances.

Chimney back The *non-combustible* wall forming the back of a *fireplace*.

Chimney breast The front *fireplace* wall construction above the *fireplace* opening.

Chimney jambs The side walls of a *fireplace*.

Code compliance certificate means a certificate issued by a *building consent authority* under section 95 of the Building Act 2004.

Amend 4
Oct 2005

Combustible See *non-combustible*.

Compliance schedule means a *compliance schedule* required under section 100 of the Building Act 2004.

Amend 4
Oct 2005

Concealed space Any part of the space within a *building* that cannot be seen from an *occupied space*.

COMMENT:

This term includes any ceiling space, roof space, space under a raised floor (such as computer rooms, floors, or stages), plenums, spaces under a tiered floor, "left-over spaces" created when some structural element or the like has been covered in; small service or duct spaces within the volume of a *firecell* and the like, but not a *protected shaft*.

Construct in relation to a *building*, includes to design, build, erect, prefabricate, and relocate the building; and **construction** has a corresponding meaning.

Dead end That part of an *open path* where escape is possible in only one direction.

COMMENT:

A *dead end* ceases to exist where the *escape route* reaches a point in the *open path* which offers alternative directions of travel, or at a *final exit* or an *exitway*.

Doorset A complete assembly comprising a door leaf or leaves including any glazed or solid panels adjacent to or over the leaves within the door frame including hardware or other inbuilt features; and a door frame, if any, with its fixings to the wall and, for a sliding or tilting door, all guides and their respective fixings to the lintel, wall or sill.

Drain A pipe normally laid below ground level including fittings and equipment and intended to convey *foul water* or *surface water* to an *outfall*.

Draught diverter A device, without moving parts, fitted in the *flue* of an appliance for isolating the combustion system from the effects of pressure changes in the secondary *flue*.

Early childhood centre A facility used for the education or care of children under the age of six, and required to be licensed under the Education (Early Childhood Centres) Regulations 1998.

Amend 4
Oct 2005

Escape height The height between the floor level in the *firecell* being considered and the floor level of the required *final exit* which is the greatest vertical distance above or below that *firecell*.

COMMENT:

1. It is necessary only to use the greatest height to the exits required for the *firecell* being considered, even though the *building* may have other *final exits* at lower or higher levels.
2. Where the *firecell* contains *intermediate floors*, or upper floors within *household units* the *escape height* shall be measured from the floor having the greatest vertical separation from the *final exit*.

Escape route A continuous unobstructed route from any *occupied space* in a *building* to a *final exit* to enable occupants to reach a *safe place*, and shall comprise one or more of the following *open paths*, *protected paths* and *safe paths*.

COMMENT:

Doors are not obstructions in an *escape route* provided they comply with C/AS1 Part 3 and D1/AS1.

Exitway All parts of an *escape route* protected by *fire* or *smoke separations*, or by distance when exposed to open air, and terminating at a *final exit*.

External wall Any exterior face of a *building* within 30° of vertical, consisting of *primary* and/or *secondary elements* intended to provide protection against the outdoor environment, but which may also contain *unprotected areas*.

Definitions

COMMENT:

A roof is an *external wall* if within 30° of the vertical.

Final exit The point at which an *escape route* terminates by giving direct access to a *safe place*.

COMMENT:

Final exits are commonly the external doors from a ground floor, but this applies only if such doors open directly onto a *safe place*. If a *safe place* can be reached only by passing down an alley, or across a bridge, then the *final exit* is not reached until the end of such an alley or bridge. *Final exits*, therefore, should be seen strictly as a point of arrival, rather than as any particular element of a *building*. They are determined entirely by the definition of *safe place*.

Fire The state of combustion during which flammable materials burn producing heat, toxic gases, or smoke or flame or any combination of these.

Firecell Any space including a group of contiguous spaces on the same or different levels within a *building*, which is enclosed by any combination of *fire separations*, *external walls*, roofs, and floors.

COMMENT:

Floors, in this context includes ground floors, and those in which the underside is exposed to the external environment (e.g. when cantilevered). Note also that internal floors between *firecells* are *fire separations*.

Firecell rating (F) The *fire resistance rating (FRR)* intended to prevent *fire* spread to another *firecell*, for sufficient time to provide for safe evacuation of occupants and protection of adjacent *household units* and sleeping areas in the *building* of *fire* origin and fire fighters engaged in fire fighting and rescue operations.

COMMENT:

1. The purpose of the *firecell rating* is to prevent premature collapse of elements of structure in order to protect:
 - a) The occupants, some of whom may have to remain in the *building* for some time while evacuation proceeds, particularly if the *building* is a large one.
 - b) Adjacent *household units* and sleeping areas in the *building* of *fire* origin.
 - c) Fire fighters engaged on rescue and fire fighting operations (although this is limited because property protection in the *building* of origin is not

- a matter covered by the New Zealand Building Code except as required by b) above).
2. The use of the *F rating* to determine the *FRR* of a *primary* or *secondary element* is discussed in C/AS1 Part 5.

Fire damper A device with a specified *FRR* complete with fixings and operating mechanism for automatically closing off an airway where it passes through a *fire separation*.

COMMENT:

An airway may be a duct, plenum, ceiling space, roof space or similar *construction* used for the passage of ventilating air.

Fire door A doorset, single or multi-leaf, having a specific *fire resistance rating*, and in certain situations a smoke control capability, and forming part of a fire separation. The door, in the event of fire, if not already closed, will close automatically and be self latching.

COMMENT:

Requirements for *fire doors* are given in C/AS1 Paragraphs 6.19.1 and 6.19.8 and Appendix C Paragraph C8.1.

Fire hazard means the danger of potential harm and degree of exposure arising from:

- a) the start and spread of *fire*; and
- b) the smoke and gases that are generated by the start and spread of *fire*.

Fire hazard category (FHC) The number (graded 1 to 4 in order of increasing severity), used to classify *purpose groups* or activities having a similar *fire hazard*, and where fully developed *fires* are likely to have similar impact on the structural stability of the *building*.

COMMENT:

Fire hazard categories are identified in C/AS1 Table 2.1.

Fire intensity The release rate of calorific energy in watts, determined either theoretically or empirically, as applicable.

Amend 4
Oct 2005

Amend 4
Oct 2005

Fire load The sum of the net calorific values of the *combustible* contents which can reasonably be expected to burn within a *firecell*, including furnishings, built-in and removable materials, and *building elements*. The calorific values shall be determined at the ambient moisture content or humidity. (The unit of measurement is MJ.)

Fire load energy density (FLED) The total *fire load* divided by the *firecell* floor area. In this calculation the floor area shall include circulation and service spaces, but exclude *exitways* and *protected shafts*.

COMMENT:

The total *fire load* is converted to *fire load energy* terms in megajoules (MJ) for calculation of the *FLED* (MJ/m²).

Fireplace A space formed by the *chimney back*, the *chimney jambs*, and the *chimney breast* in which fuel is burned for the purpose of heating the room into which it opens.

Fire resistance rating (FRR) The term used to describe the minimum *fire* resistance required of *primary* and *secondary elements* as determined in the *standard test* for *fire* resistance, or in accordance with a specific calculation method verified by experimental data from standard *fire* resistance tests. It comprises three numbers giving the time in minutes for which each of the criteria *stability*, *integrity* and *insulation* are satisfied, and is presented always in that order.

COMMENT:

1. Examples of *FRRs* are:
 - a) 30/30/15 indicating *stability* 30 minutes, *integrity* 30 minutes, *insulation* 15 minutes.
 - b) 30/-/- indicating *stability* 30 minutes, but no time requirement for *integrity* or *insulation*.
 - c) -/15/15 indicating no time requirement for *stability*, but 15 minutes for *integrity* and *insulation*.
 - d) 60/30/x indicating *stability* of 60 minutes, *integrity* of 30 minutes, and a requirement for *insulation* from C/AS1 Paragraph 5.6.4.
2. C/AS1 Part 5 gives more information on *FRRs*.

Fire resisting closure A *fire* rated device or assembly for closing an opening through a *fire separation*. It shall have a *FRR* of no less than that required for the *fire separation*.

COMMENT:

A *fire resisting closure* is intended to include *fire doors*, *fire windows* or access panels. In this context the opening may be used to permit passage of people or goods, or to transmit light, but does not include an opening to permit the passage of *building services*.

Fire resisting glazing Fixed or openable glazing, complete with frame and fixings, mullions, transoms and glazing beads, with a specified *FRR* and complying with NZS 4232 Part 2.

COMMENT:

1. The requirement for *fire resisting glazing* will not be met by ordinary window glass, or safety glasses, but rather by wired glass, or by special *fire* resisting glass shown by test to perform adequately. The nature and design of the frames also have an effect on the performance of *fire resisting glazing*.
2. Openable glazing is required by NZS 4232 Part 2 to be fitted with an automatic device which, in the event of *fire*, will close and latch the window sash.

Fire safety precautions (FSPs) The combination of all methods used in a *building* to warn people of an emergency, provide for safe evacuation, and restrict the spread of *fire*, and includes both active and passive protection.

COMMENT:

This definition has the same meaning and wording as the definition of "fire safety systems" in the Building Regulations.

Fire separation Any *building element* which separates *firecells* or *firecells* and *safe paths*, and provides a specific *fire resistance rating*.

Fire shutter A *fire* rated device, complete with fixings and operating mechanism, for automatically closing off an opening in a *fire separation* or *protected shaft*.

Fire stop A material or method of *construction* used to restrict the spread of *fire* within or through *fire separations*, and having a *FRR* no less than that of the *fire separation*.

COMMENT:

Fire stops are mainly used to seal around *penetrations*, but can also be used to seal narrow gaps between *building elements*.

Fixture An article intended to remain permanently attached to and form part of a *building*.

Flame barrier A material or system applied or installed to protect another *building element* from flame contact. The protection shall be effective for no less than 10 minutes exposure in the *standard test* for *fire* resistance.

COMMENT:

1. The principal use of *flame barriers* is to delay ignition of *foamed plastics* materials.
2. Refer to Appendix C Paragraph C10.1 for details of the test requirements for *flame barriers*.

Flammability index (FI) That index number for flammability, which is determined according to the *standard test* method for flammability of thin flexible materials.

Flue The passage through which the products of combustion are conveyed to the outside.

Flue liner Pipes or linings of *fire clay*, metal or *fire brick*, surrounding *flues*.

Flue system A series of interconnecting *flue* pipe casings which form a safe passage (*flue*) for conveying products of combustion from within an appliance to the outside of a *building* or structure.

Amend 3
Feb 2004

Foamed plastics *Combustible* foamed plastic polymeric materials of low density (typically less than 100 kg/m³) and are classified as cellular polymers which are manufactured by creating a multitude of fine void (typically 90 to 98%) distributed more or less uniformly throughout the product. Examples of *foamed plastics* are latex foams, polyethylene foams, polyvinyl chloride foams, expanded or extruded polystyrene foams, phenolic foams, ureaformaldehyde foams, polyurethane foams and polychloropene foams.

COMMENT:

1. *Foamed plastics* may be rigid or flexible, but rigid foams are the most common in *building* products. When burnt they tend to generate high levels of heat energy (kJ/kg) and varying quantities of smoke and other toxic gases depending on the nature and volume of the particular product.
2. Where doubt exists as to whether a *building* material is *foamed plastics*, an opinion should be sought from a *person* or organisation with appropriate skill and experience in *fire* engineering. That opinion should be included with the *building consent* application to the *building consent authority*.

Amend 4
Oct 2005

Group sleeping area A *firecell* containing communal sleeping accommodation for a specified number of people who may or may not be known to one another. Partial subdivision within the *firecell* is permitted with specific limitation including that no *occupied space* is fully enclosed and all *occupied spaces* are open and available to all occupants at any time. A *group sleeping area firecell* may include spaces for associated direct support functions, such as hygiene facilities and tea making (not cooking) activities, for use by the occupants. It does not include spaces, such as waiting rooms, lounges, dining rooms or kitchens, providing a communal service function for all occupants.

COMMENT:

1. Examples of *group sleeping area firecells* are dormitories, hospital wards, *wharehenui*, backpacker hostels and ski lodges.
2. The maximum number of people permitted in a *group sleeping area firecell*, and the permitted form of subdivision, will depend on the ability of the occupants to react to the presence of *fire* and escape to a *safe place*.

Handrail A rail to provide support to, or assist with the movement of a *person*.

Hazardous Creating an unreasonable risk to people of bodily injury or deterioration of health.

Hazardous substance has the meaning ascribed to it by the Fire Service Act 1975.

Hearth The insulating floor under the *fire* and in front and at the sides of the *fireplace*.

Hold-open device A device which holds a *smoke control door* or *fire door* open during normal use, but is released by deactivating the device by an automatic *fire* detection system, allowing the door to close automatically under the action of a self-closing device.

Household unit

- a) means any *building* or group of *buildings*, or part of a *building* or group of *buildings*, that is:
- i) used, or intended to be used, only or mainly for residential purposes; and
 - ii) occupied, or intended to be occupied, exclusively as the home or residence of not more than one household; but
- b) does not include a hostel, boarding house or other specialised accommodation.

Amend 4
Oct 2005

HVAC An abbreviation for heating, ventilating and airconditioning.

Insulating material A material that has a thermal conductivity of less than 0.07 W/mK.

Insulation In the context of *fire* protection, the time in minutes for which a prototype specimen, of a *fire separation* when subjected to the *standard test* for *fire* resistance, has limited the transmission of heat through the specimen.

Integrity In the context of *fire* protection, the time in minutes for which a prototype specimen, of a *fire separation* when subjected to the *standard test* for *fire* resistance, has prevented the passage of flame or hot gases.

COMMENT:

The precise meaning of *integrity* depends on the type of *building elements* being treated and how it is defined in the *standard test* being used.

Intended use, in relation to a building:

- a) includes any or all of the following:
 - i) any reasonably foreseeable occasional use that is not incompatible with the *intended use*;
 - ii) normal maintenance;
 - iii) activities undertaken in response to *fire* or any other reasonably foreseeable emergency; but
- b) does not include any other maintenance and repairs or rebuilding.

Amend 4
Oct 2005Amend 4
Oct 2005

Intermediate floor Any upper floor within a *firecell* and which is not *fire* separated from the floor below. Upper floors within *household units* need not meet the specific *fire* safety requirements which apply to *intermediate floors* in all other situations.

COMMENT:

1. An *intermediate floor* may be open to the *firecell* or enclosed with non-*fire* rated construction. If enclosed with *fire* rated walls another *firecell* is created.
2. *Household units* occur only in *purpose groups* SR and SH. Life safety provisions are governed by the limitations in permitted *open path* lengths.

Limited area atrium A single *firecell* in which individual *occupied spaces* at different levels open onto a common enclosed space. Limitations are placed on the number of *intermediate floors* (no more than two levels), individual floor areas and permitted *occupant load*, depending on the provisions for smoke detection, smoke control and the *means of escape from fire*.

COMMENT:

Typical *limited area atrium buildings* are small shopping malls, and motel complexes with a central atrium feature open to a number of floors.

Lock-out The safety shut down condition of the control system such that re-start cannot be accomplished without manual resetting.

Means of escape from fire in relation to a *building* that has a floor area,

- a) means continuous unobstructed routes of travel from any part of the floor area of that *building* to a place of safety; and
- b) includes all active and passive protection features required to warn people of *fire* and to assist in protecting people from the effects of *fire* in the course of their escape from the *fire*.

Amend 4
Oct 2005

Multi-unit dwelling Applies to a *building* or use which contains more than one separate household or family.

COMMENT:

For *fire* safety purposes each *household unit* is a separate *firecell*.

Definitions

Non-combustible Materials shall be classified as *non-combustible* or *combustible* when tested to AS 1530 Part 1.

Notional boundary The *boundary* which for *fire* safety purposes, is assumed to exist between two *buildings* on the same property under a single land title.

COMMENT:

A *notional boundary* may be located anywhere between the two *buildings* on the same property. It is not fixed and for the purposes of calculating permitted unprotected areas of each *building* it can be moved towards the other *building* thus maximising the permitted *unprotected area*.

Amend 7
Nov 2008

Occupant load The greatest number of people likely to occupy a particular space within a *building*. It is determined by:

- a) multiplying the number of people per m² (occupant density) for the activity being undertaken, by the total floor area, or
- b) for sleeping areas, counting the number of beds, or
- c) for fixed seating areas, counting the number of seats.

Occupied space Any space within a *building* in which a *person* will be present from time to time during the *intended use* of the *building*.

Open path That part of an *escape route* (including *dead ends*) within a *firecell* where occupants may be exposed to *fire* or smoke while making their escape.

Open space includes land on which there is and will be no *buildings* and which has no roof over any part of it other than overhanging eaves.

Other property means any land or *buildings* or part of any land or buildings, that are:

- a) not held under the same *allotment*; or
- b) not held under the same *ownership*; and includes a *road*.

Owner in relation to any land and any *buildings* on that land:

- a) means the *person* who:
 - i) is entitled to the rack rent from the land
 - ii) would be so entitled if the land were let to a tenant at a rack rent; and
- b) includes:
 - i) the *owner* of the fee simple of the land; and
 - ii) any *person* who has agreed in writing, whether conditionally or unconditionally, to purchase the land or any leasehold estate or interest in the land, or to take a lease of the land and is bound by the agreement because the agreement is still in force.

Amend 4
Oct 2005

Penetration A pipe, cable or duct passing through an opening in a *fire separation*.

Person with a disability means a *person* who has an impairment or a combination of impairments that limits the extent to which the person can engage in the activities, pursuits, and processes of everyday life, including, without limitation, any of the following:

- a) a physical, sensory, neurological, or intellectual impairment
- b) a mental illness.

Amend 4
Oct 2005

Person includes the Crown, a corporation sole, and also a body of *persons*, whether corporate or unincorporated.

Pitch line The line joining the leading edge or *nosings* (if any) of successive stair treads within a single flight of a *stairway*.

Primary element A *building element* providing the basic loadbearing capacity to the structure, and which if affected by *fire* may initiate instability or premature structural collapse.

COMMENT:

Suspended floors in multi-storey *buildings* are *primary elements*.

Amend 4
Oct 2005

Principal user A member of the primary group for which a *building* was constructed, and therefore explicitly excludes *persons* or groups of *persons* providing care or control of that *principal user* group.

Protected path That portion of an *exitway* within a *firecell* which is protected from the effects of smoke by *smoke separations*.

Protected shaft A space, other than a *safe path*, enclosed by *fire separations* or *external walls* used to house *building* services, lifts, or conveyors which pass from one *firecell* to another.

Purpose group The classification of spaces within a *building* according to the activity for which the spaces are used.

Railway line has the meaning ascribed to it by section 4 of the Railways Act 2005.

Relevant boundary means the *boundary* of an *allotment* which is *other property* in relation to the *building* concerned and from which is measured the separation between the *building* and that *other property*. For the *external wall* of any *building*, the *relevant boundary* shall be the nearest of the following *boundaries*:

- a) A *boundary* of a freehold *allotment*, except that where the *other property* is a road, railway line or public *open space* the *relevant boundary* is the *boundary* on the far side of that *other property*.
- b) A *boundary* of a cross lease or of a company lease or licence, except that where the *other property* is *open space* to which the lessee or licensee of the *building* concerned has an exclusive right of access and occupation or to which two or more occupiers have rights of access and occupation the *relevant boundary* is the *boundary* on the far side of that *other property*.
- c) A *boundary* shown on a unit plan excluding a *boundary* between a principal unit and its accessory unit, except that where the *other property* is

open space which is common property, the *relevant boundary* is the *boundary* on the far side of that *other property*.

COMMENT:

1. Where an easement, such as a right of way, occurs within an *allotment*, the *relevant boundary* shall remain the same as if the easement did not exist.
2. *Boundaries* within a cross-lease or company lease or licence are shown on a survey plan. In some cases the *boundary* is the *external wall* or roof of a *building*.
3. The unit title *boundaries* of principal units, accessory units, and common property are shown in the unit plan. A *boundary* is frequently an internal or *external wall*, an upper floor, or the roof of a *building*.
4. A wall along a *boundary* between two *allotments* is called a "party wall" when the *owners* of the *allotments* each have legal rights in respect of that wall registered by way of easements on one or both titles. An internal wall between cross-leases, company leases, or unit titles, or between one of them and common property, is not generally called a party wall but in that case also the lessees, unit title holders, or corporate body concerned each have legal rights in respect of that wall. Such a wall separates areas which are *other property* in relation to each other, but the wall itself is part of each property. The *fire* protection consequence of that legal concept is that such a wall can be regarded as a *fire separation* providing protection against horizontal *fire* spread in each direction. In other words, that wall may provide the appropriate *FRR* instead of each property having its own wall of that *FRR*.

Road has the meaning ascribed to it by section 315 of the Local Government Act 1974 and includes a public place and also includes a motorway.

Safe path That part of an *exitway* which is protected from the effects of *fire* by *fire separations*, *external walls*, or by distance when exposed to open air.

Safe place A place of safety in the vicinity of a *building*, from which people may safely disperse after escaping the effects of a *fire*. It may be a place such as a street, *open space*, public space or an *adjacent building*.

Secondary element A *building element* not providing load bearing capacity to the structure and if affected by *fire*, instability or collapse of the building structure will not occur.

Amend 7
Nov 2008

Definitions

Smokecell A space within a *building* which is enclosed by an envelope of *smoke separations*, or *external walls*, *roofs*, and *floors*.

Smoke control door A *doorset* with closefitting single or multi-leaves which are impermeable to the passage of smoke, fitted with smoke seals and installed within a *smoke separation*. The door, in the event of smoke, if not already closed, will close automatically and be held closed.

COMMENT:

1. A *smoke control door* may be held closed by use of a door closer. The door need not be latched.
2. Requirements for *smoke control doors* are given in C/AS1 Paragraph 6.19.1 and 6.19.8, and Appendix C Paragraph C8.1.

Smoke developed index (SDI) That index number for smoke developed when determined according to the *standard test* method for measuring the properties of lining materials.

Smoke separation Any *building element* able to prevent the passage of smoke between two spaces. *Smoke separations* shall:

- a) consist of rigid *building elements* capable of resisting without collapse:
 - i) a horizontal pressure of 0.25 kPa applied from either side, and
 - ii) self weight plus the intended vertically applied live loads, and
- b) form an imperforate barrier to the spread of smoke, and
- c) be of *non-combustible construction* or a *flame barrier*, or achieve a *FRR* of 10/10/-, except that *non-fire resisting glazing* may be used if it is toughened or laminated safety glass.

COMMENT:

1. The pressure requirement is to ensure *adequate* rigidity and is not a smoke leakage requirement.
2. Walls and floors, whether *constructed* of sheet linings fixed to studs or joists, or of concrete, metal or fired clay, need only be inspected by someone experienced in *building construction* to judge whether the *construction* is tight enough to inhibit the passage of smoke.
3. Item c) is intended to ensure that the *smoke separation* will continue to perform as an effective barrier when exposed to *fire* or smoke for a short period during *fire* development.
4. There is no requirement for *smoke control doors* or other closures in *smoke separations* to meet the provisions of item c).

Spread of flame index (SFI) That index number for spread of flame which is determined according to the *standard test* method for measuring the properties of lining materials.

Stability In the context of *fire* protection, the time in minutes for which a prototype specimen, of a *primary element* when subject to the *standard test* for *fire* resistance, has continued to carry its *fire* design load without failure.

COMMENT:

The *fire* design load should be as specified in B1/VM1.

Amend 7
Nov 2008

Stairway A series of steps or stairs with or without landings, including all necessary *handrails* and giving access between two different levels.

Standard test A test method which is recognised as being appropriate for the *fire* protection properties being assessed.

COMMENT:

A list of *standard test* methods is given in Appendix C of C/AS1.

Structural fire endurance rating (S) The *fire* resistance rating (*FRR*) intended to prevent *fire* spread or structural collapse for the complete burnout of the *firecell*.

Amend 4
Oct 2005

Suite A *firecell* providing residential accommodation for the exclusive use of one *person* or of several people known to one another. It comprises one or more rooms for sleeping and may include spaces used for associated domestic activities such as hygiene and cooking.

COMMENT:

1. Bed numbers are limited to six in *purpose groups* SC and SD or 12 in *purpose group* SA in accordance with C/AS1 Paragraphs 6.6.5 and 6.7.6. Examples may be found in hotels, motels and residential care facilities, such as old people's homes or in hospices providing temporary family accommodation.
2. It is assumed that the social cohesion of the occupants by virtue of the personal relationship (as family members, friends or associates) would ensure that any individual, becoming aware of *fire*, would naturally assist others within the *firecell* to escape. The term *suite* does not apply to a group of bedrooms where each room is available to different "key-holders". In some cases a *suite* may be a single bedroom.

Surface finish The combination of a surface coating and substrate material on surfaces of *building elements* exposed to view. It can be an applied decorative coating or the uncoated *building element* itself. For interior surfaces the requirements are evaluated in terms of *SFI* and *SDI*. For exterior surfaces the requirements are evaluated in terms of rate of heat release as determined by Appendix C, paragraph C9.1.

Theatre A place of assembly intended for the production and viewing of performing arts, and consisting of an auditorium and stage with provision for raising and suspending stage scenery above and clear of the working area.

Travel distance The length of the *escape route* as a whole or the individual lengths of its parts, namely:

- a) *open paths*
- b) *protected paths* and
- c) *safe paths*.

Unprotected area in relation to an *external wall* of a *building*, means any part of the *external wall* which is not *fire* rated or has less than the required *FRR*.

COMMENT:

Unprotected area includes non-*fire* rated windows, doors, or other openings, and non-*fire* rated *external wall construction*.

Wharenui A communal meeting house having a large open floor area used for both assembly and sleeping in the traditional Maori manner.

Verification Method C/VM1

1.1 Solid Fuel Appliances

Limiting heat transfer

1.1.1 Compliance with NZBC Performance C1.3.2 may be verified for solid fuel burning appliances by meeting the appropriate test requirements of AS/NZS 2918.

Amend 3
Feb 2004

Acceptable Solution C/AS1

Part 1: Introduction

1.1 Scope

1.1.1 This acceptable solution is one way, but not the only way, of satisfying the New Zealand Building Code (NZBC) provisions for fire safety in *buildings*.

1.1.2 The methods given are particularly appropriate for simple, low-rise *buildings*. However, for individual *buildings*, alternative solutions developed from specific fire engineering design could produce more economical results.

Defined terms and comments

1.1.3 Italicised words and terms in the text of this acceptable solution are specifically defined at the front of the document. It is important for users to be familiar with those definitions.

1.1.4 Shading and a smaller font are used to distinguish comments from the main text. Comments are not part of the acceptable solution but are used to provide explanations, background information and guidance to the user.

Reference documents

1.1.5 This acceptable solution often refers to information already available in other recognised publications. It is essential for users to be familiar with the content of those publications if applying them to a specific *building*. A summary of reference publications is given at the front of this document.

Tables

1.1.6 Much of the information for determining specific fire safety requirements is contained in tables. For the convenience of regular users tables are grouped at the end of each Part to which they refer.

1.2 Using this Document

1.2.1 How this Approved Document is applied to a particular project will depend on the type of *building* and the role and experience of the user.

Those familiar with the document, or a specific *building*, may decide initially to apply Part 4 and establish the number, nature and distribution of *firecells*. Others might start with Part 7 to determine the restrictions imposed by an adjacent *boundary*.

The following information is provided as a guide for those who are unfamiliar with the document and are not fire engineering specialists.

1.2.2 In assessing the fire safety provisions for any *building*, or part of a *building*, the first requirement is to determine the *building use*, defined as the *purpose group*. Part 2 provides this information.

1.2.3 Next, knowing the *purpose group*, it is necessary to determine *escape route* requirements and the required *fire safety precautions (FSPs)* including fire alarm systems. The provisions for *escape routes* are given in Part 3 and for *fire safety precautions* in Part 4.

1.2.4 Most *building consents* are issued for low rise residential *buildings* (detached dwellings and *multi-unit dwellings* up to 2 or 3 levels) and small single floor *buildings*. The main requirements for those *buildings* are the provision of *adequate escape routes* and, where close to a *relevant boundary*, protection against fire spread to neighbouring property (including adjoining *household units*).

1.2.5 The space occupied by *escape routes*, and their location, can be a limiting factor on available floor area for the proposed use, particularly on restricted *building sites* and where *alterations* or a change of use are involved. However, where it is apparent that *escape route* provisions are difficult to achieve, reference should be made to Part 3 Paragraph 3.5 for the relaxations offered when various fire alarm systems are installed. It is also advisable to check whether Table 4.1 makes any such system a mandatory requirement.

1.2.6 For other than conventional residential and small single use *buildings*, such things as the *escape height*, *building geometry* and

occupancy can significantly influence *fire* safety requirements, particularly with respect to the *fire separation* of different activities and prevention of *fire* spread to neighbouring property. The necessary provisions are based on subdividing the *building* into *firecells*, each with appropriate *FSPs*, and applying *fire resistance ratings (FRRs)* to *building elements* as explained in Parts 4 to 7.

1.2.7 Paragraph 1.3 provides the user with a suggested design sequence for applying this acceptable solution to any type of *building*, and a less detailed procedure appropriate for smaller residential *buildings*. Most of the more detailed provisions of this Approved Document, which concern larger *buildings* and greater *fire hazard* activities, do not apply to the majority of residential accommodation.

1.3 Recommended Design Sequence

General approach

1.3.1 Application of this acceptable solution depends largely on the basic measurements such as *building height*, floor plans, wall openings and distances to *relevant boundaries*. Users should determine those measurements as accurately as possible before using this document.

COMMENT:

Future flexibility. It is very likely that a *building*, over its lifetime, will undergo one or more changes in use. Even under the same use, floor layout and furnishing will *alter* to accommodate changes in technology and occupant practices. *Owners* should therefore consider the advantages, at initial *construction* time, of providing for *fire safety precautions* to suit alternative occupancies. These could be difficult or excessively expensive to install at a later date.

1.3.2 It is recommended that, in general, the following design sequence be used:

- Step 1 Determine the application of the Building Act. (Is the project a new *building*, an *alteration* to an existing *building*, or a change of use of a *building*?)
- Step 2 Determine the *owner's* requirements.
- Step 3 Determine the *purpose groups*, and *fire hazard categories (FHCs)* (use Part 2).

- Step 4 Determine the number and distribution of occupants (use Part 2).
- Step 5 Determine the *means of escape from fire* from all *firecells* (use Part 3). This can influence the floor plan and may require reassessment of Step 4.
- Step 6 Determine the number of *firecells* for life safety, *firecell (F) rating* and *fire safety precautions (FSPs)* (use Part 4).
- Step 7 Determine any additional protection and *structural fire endurance (S) ratings*, if required (use Part 5).
- Step 8 Determine the *fire resistance rating (FRR)* of *building elements* including requirements for structural *stability* (use Part 5).
- Step 9 Determine requirements for control of internal *fire* spread (use Part 6).
- Step 10 Determine requirements for control of external *fire* spread (use Part 7).
- Step 11 Determine the requirements for *fire* fighting (use Part 8).
- Step 12 Determine requirements to control outbreak of *fire* (use Part 9).

Detached dwellings

1.3.3 Detached dwellings are *purpose group SH* and have restrictions on *escape route* lengths and the use of exposed *foamed plastics* materials, but few other specific *fire* safety requirements, unless sited close to a *relevant boundary* or having an *escape height* of greater than 10 m (4 or more floor levels).

1.3.4 It is recommended that for *purpose group SH* the following design sequence be used:

- Step 1 Check that the proposed *construction* is in accordance with the description of *SH* activities (see Table 2.1).
- Step 2 Check *escape route* lengths to ensure that *dead ends* do not exceed 24 m and total *open paths* do not exceed 60 m (see Table 3.3).
- Step 3 If wall or ceiling linings contain *foamed plastics* materials, check compliance with Table 6.3 (see Paragraph 6.20.1).

Amend 5
Oct 2005

Step 4 Check whether *external walls* are required to be *fire rated*. A *FRR* of 30/30/30 is necessary where the *external wall* is within 1.0 m of the *relevant boundary* (see Paragraph 7.10.6), or roof eaves project within 650 mm of the *boundary* (see Paragraph 7.8.5).

Step 5 Where an open sided carport is part of the *construction*, check specific provisions (see Paragraphs 7.8.8 to 7.8.10).

Amend 5
Oct 2005

Step 6 Where the *escape height* exceeds 10 m, apply an *FRR* based on the *S rating* to parts of the *external wall* not permitted to be *unprotected areas* (see Paragraph 7.10.8). If the *building height* exceeds 10 m apply the requirements for *external wall surface finishes* (see Paragraphs 7.11.2 and 7.11.4).

Multi-unit dwellings

1.3.5 *Multi-unit dwellings* are *purpose group SR*. For low-rise *buildings*, having no more than two levels (one *household unit* above another) and containing only *SR purpose group*, the *fire safety* requirements are similar to those for *purpose group SH* (see Paragraphs 1.3.3 and 1.3.4) provided that each *household unit*:

- a) Has a separate *escape route*, and
- b) Is *fire separated* from other *household units* with *fire separations* having a *FRR* of no less than 30/30/30.

1.3.6 For other *multi-unit dwellings* the *fire safety* requirements depend on such things as:

- a) The *escape height*,
- b) The number of *household units*,
- c) Whether the *household units* are under single *ownership* or have unit titles,
- d) Whether *escape routes* are shared,
- e) Whether enclosed car parking spaces are shared by different *household units*, and
- f) Whether the *building* contains other *purpose groups*.

COMMENT:

1. The definitions of *intermediate floor* and *relevant boundary* have specific relevance for *SR purpose group*.
2. The following is an abbreviated list of some key references relating to *SR accommodation*. Users should always refer to the relevant quoted paragraph or table before applying the information to a specific project.

Description of types of <i>construction</i> classified as <i>purpose group SR</i>	Reference Paragraph or Table
Description of types of <i>construction</i> classified as <i>purpose group SR</i>	Table 2.1
Number of <i>escape routes</i>	Table 3.1
Conditions permitting single <i>escape routes</i>	3.15
Width of <i>escape routes</i>	Table 3.2
<i>Open path</i> lengths and increases for <i>FSPs</i>	3.5 and Table 3.3
Exit doors from <i>household units</i> to open directly onto a <i>safe path</i> or <i>final exit</i>	3.11.6
<i>Safe path</i> termination	3.16.8
<i>Safe path</i> combined with other <i>purpose groups</i>	3.16.9
Requirement for <i>hold-open devices</i>	3.17.9
<i>FSP</i> requirements	Table 4.1/5
<i>FSP</i> requirements on floors below <i>SR</i>	4.5.11
<i>Fire separation</i> of <i>household units</i>	6.8.1
Enclosed car parking	6.8.4
<i>Household unit</i> with upper floors treated as single floor when determining <i>FSPs</i>	6.8.6
<i>Exitway</i> ventilation	6.9.6 to 6.9.10
<i>Protected shafts</i> (lifts, solid waste and linen chutes)	3.12.3, 6.16
Restriction of roof and ceiling space areas	6.18.7 to 6.18.10
No restriction on interior <i>surface finishes</i> within <i>household units</i> except for <i>foamed plastics</i>	6.20.1
Separation of legal titles	7.2
Preventing horizontal <i>fire spread</i>	7.3.1
Enclosing rectangle relaxation for <i>SR</i>	7.5.7
<i>External wall</i> rating if eaves within 650 mm of <i>relevant boundary</i>	7.8.5
Rating of floor projections within 1.0 m of <i>relevant boundary</i>	7.8.6
Protection against <i>fire spread</i> from a lower roof	7.9.6, 7.9.9
<i>Fire spread</i> from lower <i>firecells</i>	7.9.10
<i>FRRs</i> for <i>external wall</i>	7.10.6 to 7.10.8

Amend 5
Oct 2005

Acceptable Solution C/AS1

Part 2: Occupant Numbers and Purpose Groups

2.1 General

2.1.1 Designing a *building* to provide *adequate fire safety*, involves decisions on both the *construction materials* and layout needed to reduce the perceived risk to an acceptable level.

2.1.2 The risk is assessed according to:

- a) The number and mobility of the occupants (*occupant load*).
- b) The activities undertaken within the *building*.
- c) The nature of the *building materials* and contents.

2.1.3 That assessment allows each *building space* to be categorised in a *purpose group* (see Table 2.1) which is the basis for determining *fire safety precautions*.

2.2 Purpose Groups and Fire Hazard Categories

2.2.1 Table 2.1 shall be used to determine the *purpose group* appropriate to the activity, and the *fire hazard category (FHC)*. When a specific activity is not shown in Table 2.1, the nearest suitable *purpose group* and *fire hazard category* must be chosen.

COMMENT:

- 1. The *purpose group* is used as an entry point to several parts of this acceptable solution, e.g. when determining the number and size of *exitways* and other *fire safety precautions*.
- 2. The *fire hazard category* is used to determine the *S rating* requirements of Part 4. While there is a relationship between the *fire hazard category* and the *Fire Load Energy Density (FLED)*, it is recognised that *FLED* is only one factor affecting the *fire severity* and thus the impact of the *fire* on the *building structure*.

Other important factors may include ventilation, surface area to mass ratio of the fuel, and its rate of burning. The *fire hazard category* was chosen in preference to *FLED* because it is better able to categorise certain spaces containing mainly low heat release rate fuels (e.g. frozen meat carcasses).

3. The *S ratings* in Table 5.1 are classified in terms of *fire hazard category*. While *FHC* covers more than just the energy density of *fire load*, there is a direct link between these two parameters, as tabulated below:

Fire Hazard Category (Note 1)	Range of FLED (MJ/m ²) (Note 2)	Design Value of FLED (MJ/m ²) (Notes 2, 3)
1	0 - 500	400
2	501 - 1000	800
3	1001 - 1500	1200
4	> 1500	
Column 1	2	3

NOTES:

- 1. The *fire hazard category* for a given *purpose group* is given in Table 2.1.
- 2. *FLED* is expressed as MJ *fire load* per m² floor area and is the sum of the *fire loads* from all of the *combustible materials* divided by the floor area of the space. *Fire load* is calculated for each *combustible material* as *Fire Load (MJ) = Combustible Mass (kg) x Heat of Combustion (MJ/kg)*.
- 3. Each *fire hazard category* covers a number of *purpose groups* with design (80 percentile) *fire load energy densities* of these groups lying in the range stated in column 2 of the above table. The design value of *FLED* for *fire determination of S rating* associated with each *fire hazard category* is also taken as the 80 percentile value of this range, in accordance with accepted practice. This design value adopted also directly covers the specific *FLED* associated with almost all *purpose group uses* which come within each *fire hazard category*.

Primary purpose group for multiple activities

2.2.2 Where a *building* contains a number of different activities which individually may be categorised in different *purpose groups*, the *purpose group* designated for a particular *firecell* of a *building* shall be that of the primary *purpose group*. The primary *purpose group* shall be that one, within the *firecell*, requiring the most severe *fire safety precautions* (see exception in Paragraph 5.6.7).

2.2.3 For example, a floor of a hotel containing a dining room, kitchen, conference room and administration offices, in addition to the sleeping areas, will be categorised in *purpose group* SA (sleeping accommodation). In comparison, a tavern with similar facilities but no accommodation, would be in *purpose group* CS or CL (crowd activities).

2.2.4 Depending on the particular *building* and the uses or activities within that *building*, there may be several primary *purpose groups*, with one or more on each floor.

2.2.5 For example, levels of a multi-storey *building* may be categorised in different *purpose groups* such as:

Basement carparks	IA
Shopping floors	CM
Office floors	WL
Domestic accommodation	SR

A single floor may also contain several *purpose groups* such as:

Offices	WL
Shops	CM
Cafeteria	CS or CL depending on occupant load

Purpose groups CS and CL

2.2.6 A *building*, such as a school, may have a number of separate spaces containing fewer than 100 occupants. Each space therefore satisfies the description of *purpose group* CS. However, if those spaces are contained in a single *firecell* and the total occupancy exceeds 100, that *firecell* must be classified as *purpose group* CL.

2.2.7 Where a CS *purpose group* is a support activity, such as a conference room used occasionally by people in an office complex, the space may be included under the primary *purpose group* WL.

Purpose group SH

2.2.8 The only *fire* safety requirements for *purpose group* SH (detached dwellings) are restrictions on *open path* lengths and the *fire* rating of *external walls* and eaves close to the *relevant boundary*. Those requirements are summarised in Paragraphs 1.3.3 and 1.3.4.

Purpose group SA treated as SR or SH

2.2.9 Where any part of an SA *purpose group* consists of self contained *suites*, each with no more than 12 beds then:

- a) Where the *suites* are attached, have an *escape height* of no more than 34 m and are used as *household units*, the requirements of *purpose group* SR may be applied.

COMMENT:

Treatment as an SR *purpose group* is permitted only where an SA *suite* is used as a residential dwelling. For example, where occupied by the *owner* or manager of the *building*. Treatment as SR does not apply to transient occupancy.

- b) Where the *suites* are detached, the requirements of *purpose group* SH may be applied.

COMMENT:

Under Clause A1 2.0.2 of the NZBC, a boarding house accommodating fewer than six people, may be treated as a detached dwelling.

Fire hazard category 4

2.2.10 *Fire hazard category* 4 includes materials with a *fire load energy density (FLED)* of greater than 1500 MJ/m², and materials which have a *fire* growth rate of 1 MW or more in less than 75 seconds. Any *firecell* with a *fire hazard category* of 4 (FHC 4) shall have the *S rating* determined by *fire* engineering design (see Paragraph 5.6.11). Table 2.1 provides an indication of where *fire hazard category* 4 is likely to apply, but the examples given are not

Amend 5
Oct 2005

Amend 5
Oct 2005

Amend 5
Oct 2005

exhaustive. Paragraph 5.6.12 describes the circumstances in which the *fire hazard category* may be reduced if the *FHC 4 purpose group* comprises only a small proportion of the *firecell*.

2.3 Occupant Load

2.3.1 The size and location of *escape routes* and the *fire safety precautions* applied to them in a *building* are related to the *occupant load*.

2.3.2 The *occupant load* is determined from the *purpose group* and number of people in each space of the *building*, and may need to be evaluated not only for each *purpose group*, but also for:

- a) A space or open floor area involving one or more activities.
- b) A floor containing more than one *purpose group*.
- c) A single *firecell*.
- d) Each floor within a *firecell*.

2.3.3 *Occupant loads* may be calculated from the occupant densities given in Table 2.2 based on the floor area of the part of the *building* housing the activity. Where a *building* space has alternative activity uses, the activity having the greatest occupant density shall be used. For an activity not specifically described in Table 2.2, the nearest reasonable description should be used.

COMMENT:

When using Table 2.2 to calculate the *occupant load* note that:

- a) The floor area to be used is the total *firecell* floor area (except where Paragraph 2.3.4 applies) including that occupied by internal partitions and permanent *fixtures*.
- b) Table 2.2 occupant densities already allow for a proportion of the floor area, appropriate to the activity, being occupied by furniture, partitions, *fixtures* and associated equipment.

2.3.4 Duplication should be avoided by:

- a) Ensuring that where people may be involved in more than one activity, they are counted only once, and

- b) Not including an *occupant load* for *exitways*, lift lobbies, sanitary facilities etc, used intermittently by people already counted elsewhere in the *building*.

Fixed seating

2.3.5 *Occupant load* assessment shall take account of the actual arrangement and number of seats for fixed seating (see Paragraph 3.9.3). Where additional floor area abuts the fixed seating, additional occupants may be allowed for based on standing space density, provided the *escape route* is not obstructed.

Where occupancy is based on number of beds

2.3.6 In *purpose groups* SC, SD and SA, the actual number of beds shall be used for determining the number of occupants.

COMMENT:

1. In this acceptable solution the term “beds” is used to denote the number of people expected to be sleeping in the *firecell*. Therefore, a double bed counts as two beds, and a tier of three single bunks (one above another) counts as three beds.
2. The number of beds depends on the individual layout in every case. Clearly dormitories will have a far greater number of beds within any given area than single bedrooms in a hospital or an old people's home, which may have individual lounge areas, toilets and kitchenettes attached. During use, the number of bed spaces must not be increased beyond that initially provided for unless a new *building consent* is obtained.

Justification for exceptions

2.3.7 Where, for a particular situation, the *occupant load* derived from Table 2.2 is clearly more than that which will occur, the basis of any proposal for a lesser *occupant load*, shall be substantiated to the *building consent authority*.

COMMENT:

Designing a *building* for a reduced *occupant load* can severely restrict future occupancy options, and may involve significant expense in meeting the means of escape provisions for increased numbers.

Amend 7
Nov 2008

2.4 Residential Community Care
.....

Text to be confirmed.

Amend 5
Oct 2005

Table 2.1: Purpose Groups Paragraphs 1.3.4, 2.1.3, 2.2.1, 2.2.10, 5.6.11 and 5.6.13			
Purpose group	Description of intended use of the building space	Some examples	Fire hazard category
CROWD ACTIVITIES			
CS or CL	For <i>occupied spaces</i> . CS applies to <i>occupant loads</i> up to 100 and CL to <i>occupant loads</i> exceeding 100.	Cinemas when classed as CS, art galleries, auditoria, bowling alleys, churches, clubs (non-residential), community halls, court rooms, dance halls, day care centres, gymnasia, lecture halls, museums, eating places (excluding kitchens), taverns, enclosed grandstands, indoor swimming pools.	1
		Cinemas when classed as CL, schools, colleges and tertiary institutions, libraries (up to 2.4 m high book storage), nightclubs, restaurants and eating places with cooking facilities, <i>early childhood centres</i> theatre stages, opera houses, television studios (with audience).	2
CO	Spaces for viewing open air activities (does not include spaces below a grandstand).	Libraries (over 2.4 m high book storage).	3
		Open grandstands, roofed but unenclosed grandstand, uncovered fixed seating.	1
CM	Spaces for displaying, or selling retail goods, wares or merchandise.	Exhibition halls, retail shops.	2
		Supermarkets or other stores with bulk storage/display over 3.0 m high.	4
SLEEPING ACTIVITIES			
SC	Spaces in which <i>principal users</i> because of age, mental or physical limitations require special care or treatment.	Hospitals. Care institutions for the aged, children, <i>people with disabilities</i> .	1
SD	Spaces in which <i>principal users</i> are restrained or liberties are restricted.	Care institutions, for the aged or children, with physical restraint or detention.	1
		Hospital with physical restraint, detention quarters in a police station, prison.	
SA	Spaces provided for the use of people who will be transient and reside for a temporary period, typically not more than 90 days, or where limited assistance or care is provided for <i>principal users</i> .	Motels, hotels, hostels, boarding houses, clubs (residential), boarding schools, dormitories, halls of residence, <i>wharehnu</i> , community care institutions.	1
SR	Attached and multi-unit residential dwellings.	<i>Multi-unit dwellings</i> or flats, apartments, and includes <i>household units</i> attached to the same or other <i>purpose groups</i> , such as caretakers' flats, and residential accommodation above a shop.	1
		<i>Household unit firecells</i> may contain garages which are used exclusively by the occupants of that <i>household unit</i> .	
		Excludes sleeping accommodation used for a temporary period typically no more than 90 days	
SH	Detached dwellings where people live as a single household or family.	Dwellings, houses, being <i>household units</i> , or <i>suites</i> in <i>purpose group</i> SA, separated from each other by distance. Detached dwellings may include attached self-contained <i>suites</i> such as granny flats when occupied by a member of the same family, and garages whether detached or part of the same <i>building</i> and are primarily for storage of the occupants' vehicles, tools and garden implements.	1

Amend 4
Oct 2005

Errata
Jul 2001

Amend 7
Nov 2008

Amend 7
Nov 2008

Table 2.1: Purpose Groups (continued)

Purpose group	Description of intended use of the building space	Some examples	Fire hazard category
WORKING, BUSINESS OR STORAGE ACTIVITIES			
WL	Spaces used for working, business or storage – low <i>fire load</i> .	Manufacturing, processing or storage of <i>non-combustible</i> materials, or materials having a slow heat release rate, cool stores, covered cattle yards, wineries, grading or storage or packing of horticultural products, wet meat processing.	1
		Banks, hairdressing shops, beauty parlours, personal or professional services, dental offices, laundry (self-service), medical offices, business or other offices, police stations (without detention quarters), radio stations, television studios (no audience), small tool and appliance rental and service, telephone exchanges, dry meat processing.	2
WM	Spaces used for working, business or storage – medium <i>fire load</i> and slow/medium/fast <i>fire growth rates</i> (e.g. <1 MW in 75 sec) (Note 1) .	Manufacturing and processing of <i>combustible</i> materials not otherwise listed, including bulk storage up to 3 m high (excluding <i>foamed plastics</i>).	3
WH	Spaces used for working, business or storage – high <i>fire load</i> and slow/medium/fast <i>fire growth rates</i> (e.g. <1 MW in 75 sec) (Note 1) .	Chemical manufacturing or processing plants, distilleries, feed mills, flour mills, lacquer factories, mattress factories, rubber processing plants, spray painting operations, plastics manufacturing, bulk storage of <i>combustible</i> materials over 3 m high (excluding <i>foamed plastics</i>).	4
WF	Spaces used for working, business or storage – medium/high <i>fire load</i> and ultra fast <i>fire growth rates</i> (e.g. >1 MW in 75 sec) (Note 1) .	Areas involving significant quantities of highly <i>combustible</i> and flammable or explosive materials which because of their inherent characteristics constitute a special <i>fire hazard</i> , including: bulk plants for flammable liquids or gases, bulk storage warehouses for flammable substances, bulk storage of <i>foamed plastics</i> .	4 (The critical factor in this <i>purpose group</i> is the rate of <i>fire growth</i> .)
INTERMITTENT ACTIVITIES			
IE	<i>Exitways on escape routes.</i>	<i>Protected path, safe path.</i>	1
IA	Spaces for intermittent occupation or providing intermittently used support functions – low <i>fire load</i> .	Car parking, garages, carports, enclosed corridors, unstaffed kitchens or laundries, lift shafts, locker rooms, linen rooms, open balconies, <i>stairways</i> (within the <i>open path</i>), toilets and amenities, and service rooms incorporating machinery or equipment not using solid-fuel, gas or petroleum products as an energy source (Note 2) .	1
ID	Spaces for intermittent occupation or providing intermittently used support functions – medium <i>fire load</i> .	Maintenance workshops and service rooms incorporating machinery or equipment using solid-fuel, gas or petroleum products as an energy source (Note 2) .	3
Notes:			
1. Refer to NFPA 92B for more information on <i>fire growth rates</i> .			
2. Service rooms are spaces designed to accommodate any of the following: boiler/plant equipment, furnaces, incinerators, refuse, caretaking/cleaning equipment, airconditioning, heating, plumbing or electrical equipment, pipes, lift/escalator machine rooms, or similar services.			

Table 2.2: Occupant Densities
Paragraphs 2.3.3 and 2.3.7

Activity	Occupant density (Users/m ²) (see Note 1)
CROWD ACTIVITIES	
Airports – baggage claim	0.5
Airports – concourses	0.1
Airports – waiting areas, check in	0.7
Area without seating or aisles	1.0
Art galleries, museums	0.25
Bar sitting areas	1.0
Bar standing area	2.0
Bleachers, pews or similar bench type seating	2.2 users per linear metre
Classrooms	0.5
Dance floors	1.7
Day care centres	0.25
Dining, beverage and cafeteria spaces	0.8
Exhibition areas, trade fairs	0.7
Fitness centres	0.2
Gymnasias	0.35
Indoor games areas/bowling alleys, etc	0.1
Libraries – stack areas	0.1
Libraries – other areas	0.15
Lobbies and foyers	1.0
Mall areas used for assembly purposes	1.0
Reading or writing rooms and lounges	0.5
Restaurants, dining rooms and lounges	0.9
Shop spaces and pedestrian circulation areas including malls and arcades	0.3
Shop spaces for furniture, floor coverings, large appliances, building supplies and manchester	0.1
Showrooms	0.2
Space with fixed seating	as number of seats (see Note 2)
Space with loose seating	1.3
Spaces with loose seating and tables	0.9
Stadia and grandstands	1.8
Stages for theatrical performances	1.3
Standing space	2.6
Swimming pools (water surface area)	0.2
Swimming pool surrounds and seating	0.35
Teaching laboratories	0.2
Vocational training rooms in schools	0.1

Table 2.2: Occupant Densities (continued)

Activity	Occupant density (Users/m ²) (see Note 1)
SLEEPING ACTIVITIES	
Bedrooms	as number of beds
Bunkrooms	(see Note 2)
Detention quarters	
Dormitories, hostels	
Halls and <i>wharehenui</i> (Note 5)	
Wards containing more than two beds	
WORKING BUSINESS AND STORAGE ACTIVITIES	
Aircraft hangars	0.02
Bulk storage (e.g. solid stacked)	0.01
Commercial laboratories, laundries	0.1
Computer rooms (not used as classrooms for training)	0.04
Factory space in which layout and normal use determines the number of people using it in working hours	as approved (see Note 3)
Heavy industry	0.03
Interview rooms	0.2
Kitchens	0.1
Manufacturing and process areas, staffrooms	0.1
Offices and staffrooms	0.1
Personal service facilities	0.2
Reception areas	0.1
Workrooms, workshops	0.2
Warehouse storage (e.g. racks and shelves)	0.03
INTERMITTENT ACTIVITIES (see Note 4)	
Boiler rooms, plant rooms, service units and maintenance workshops	0.03
Parking <i>buildings</i> , garages	0.02
<i>Exitways</i> , enclosed corridors, lifts (no occupants counted)	0.0
Laundry and house keeping facilities	0.2
Storage	0.02
Toilets and subordinate spaces (no occupants counted)	0.0
Notes:	
<ol style="list-style-type: none"> The floor area to be used shall be the total <i>firecell</i> floor area including that occupied by internal partitions and <i>fixtures</i>. The occupant densities in this table already allow for a proportion of floor area, appropriate to the activity, being occupied by furniture, partitions, <i>fixtures</i> and associated equipment. For fixed seating and beds, the number of seats or beds is used instead of an occupant density (users per m²). In such cases, the <i>occupant load</i> must be specified when seeking a <i>building consent</i>. Future increase in numbers shall be treated as a change of use. Spaces for intermittent activities (<i>purpose groups</i> IE, IA, ID), are normally not assessed for <i>occupant load</i>. It is assumed that the occupation is temporary and by people who would already have been included in the <i>occupant load</i> of another space. The figures given in the table apply where people are specifically employed to perform the functions for which the spaces are provided. For halls and <i>wharehenui</i>, the maximum <i>occupant load</i> is determined by the <i>fire safety precautions</i> and the escape capacity. See Paragraphs 3.3.2 h), 3.4.2 e), 6.7.2 and 6.7.9. 	

Acceptable Solution C/AS1

Part 3: Means of Escape

3.1 General Principles

3.1.1 All buildings shall have means of escape from fire which, include escape routes. An escape route (see Figure 3.1) shall provide adequate protection to any occupant escaping to a safe place from a fire within a building.

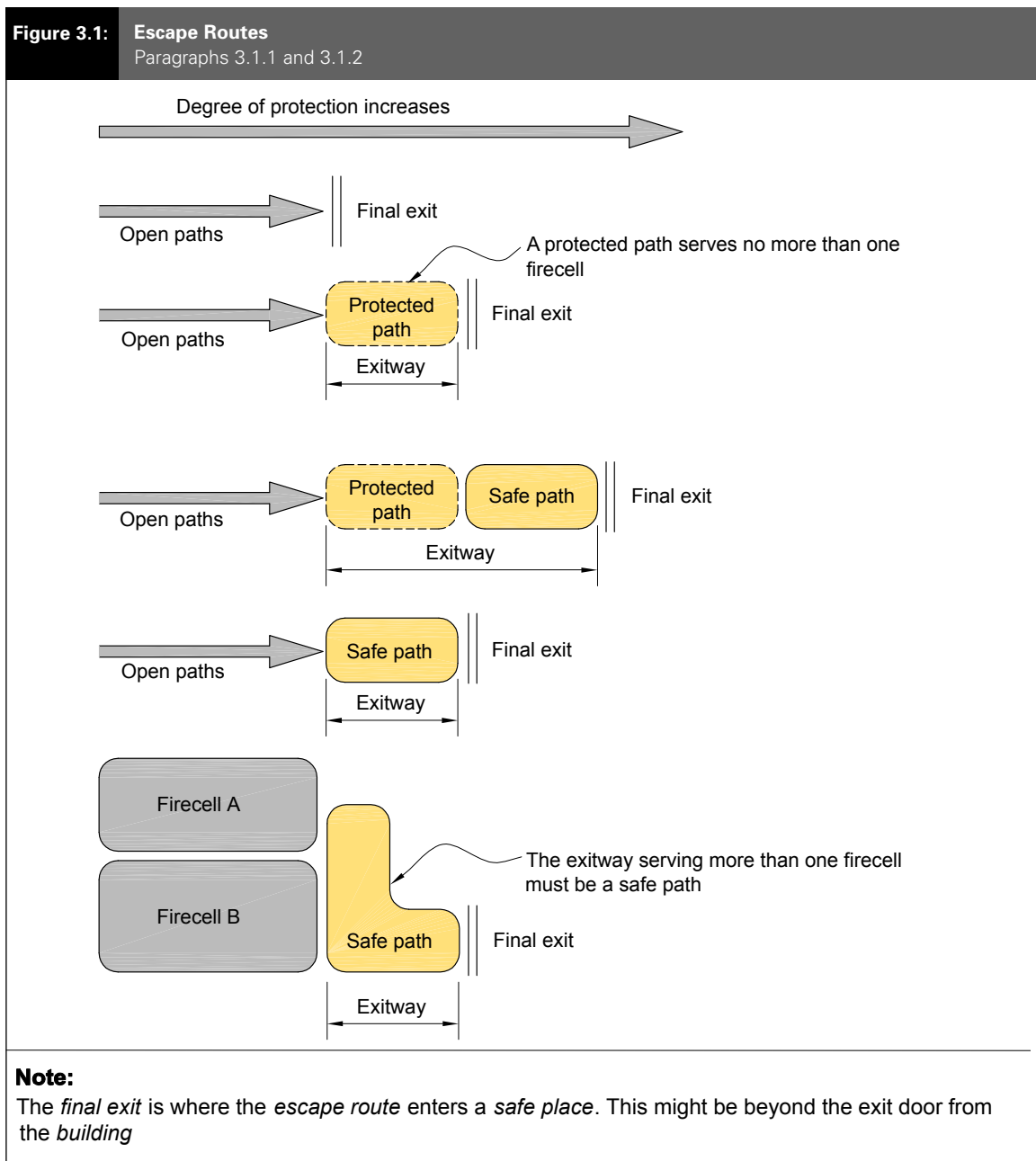

3.1.2 Components of an *escape route* in ascending order of protection are the *open path*, *protected path*, *safe path* and *final exit* (see Figure 3.1). Depending on the total *travel distance*, one or more of these components are necessary. An *escape route* shall not pass from a higher to lower level of protection in the direction of escape.

3.1.3 Provided the allowable lengths of *open paths* and *protected paths* are not exceeded, an *escape route* may comprise only an *open path* (or *open path* and *protected path*) and *final exit*.

3.1.4 *Escape routes* shall comply with NZBC Clause D1.3.3 Access Routes. Ramps, stairs, ladders, landings, *handrails*, doors, vision panels and openings shall comply with D1/AS1, except that dispensations may be allowed for windows, as described in Paragraph 3.18.

Advantages of FSPs

3.1.5 Advantages in the size and *construction* of both *firecells* and *escape routes* may be gained by the use of *fire safety precautions* involving smoke detectors, heat detectors and sprinklers. Table 4.1 describes circumstances where such *FSPs* are mandatory. Paragraph 3.5 describes permitted increases in *open path* length for specific *purpose groups* where one or more of those *FSPs* are installed.

3.2 Number of Escape Routes

3.2.1 Except where Paragraph 3.15 allows the use of single *escape routes*, every *occupied space* in a *building* shall be served by two or more *escape routes* (see Figure 3.2).

3.2.2 Table 3.1 gives the minimum number of *escape routes* needed for a given *occupant load*.

Figure 3.2: Minimum Number of Escape Routes
Paragraph 3.2.1

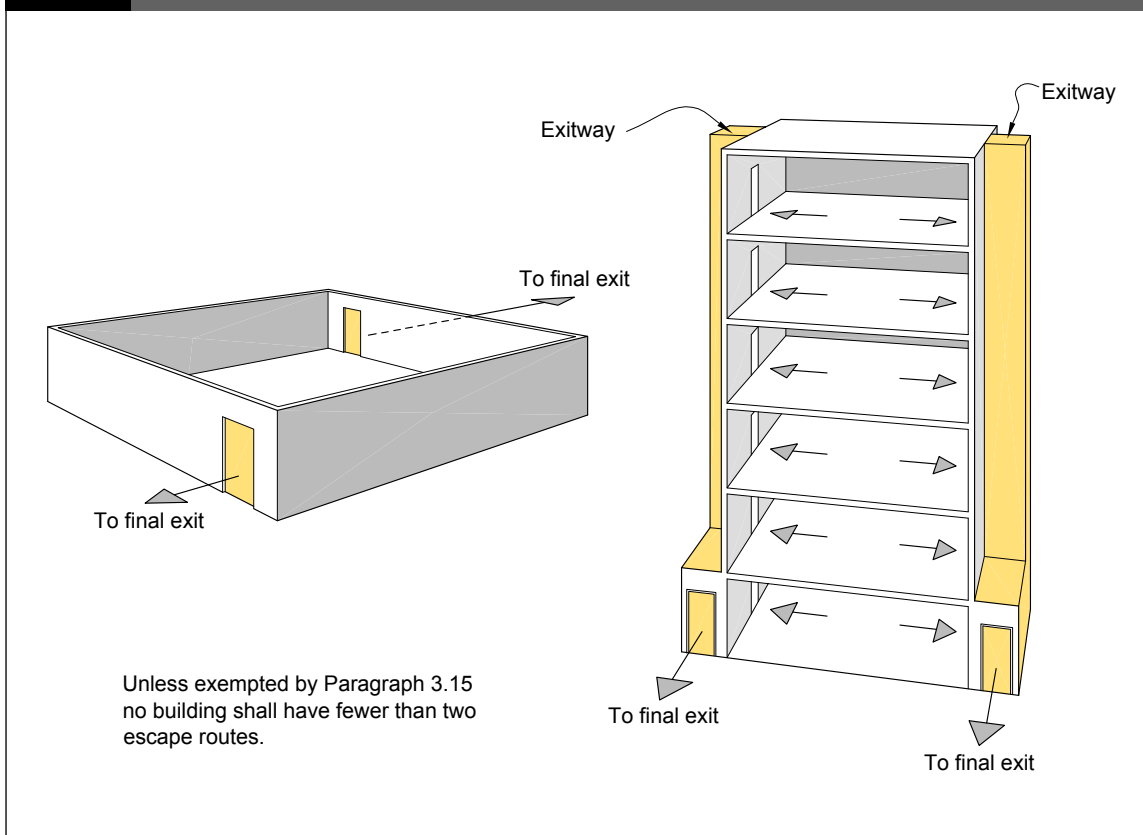

3.3 Height and Width of Escape Routes

Height

3.3.1 Within *escape routes*:

- a) The clear height shall be no less than 2100 mm across the full width, except that isolated ceiling fittings not exceeding 200 mm in diameter may project downwards to reduce this clearance by no more than 100 mm, and
- b) Any *smoke control door* or *fire door* opening within, or giving access to any *exitway*, shall have a clear height of no less than 1955 mm for the required width of the opening.

Width

3.3.2 Widths of *escape routes* shall be no less than required by Table 3.2 for both the width of individual *escape routes*, and the total combined width of all available *escape routes*, but:

- a) **Exitways.** The width of an *escape route* within an *exitway* shall be no less than 1000 mm.
- b) **Provision for unusable escape route.** Except where *dead ends* and single *escape routes* are permitted, in unsprinklered *firecells* the total required width shall still be available should one of the *escape routes* be unusable due to the location of the *fire* or any other reason (see Figure 3.3).

COMMENT:

1. This may be achieved either by providing additional *escape routes* or by making the minimum required number wider.
2. This means that where two *escape routes* are required by Table 3.1, and no additional *escape route* is provided, each *escape route* shall be sized for the required total width. Similarly, if the table requires three *escape routes*, and no additional *escape route* is provided, widths shall be chosen to ensure that any two *escape routes* provide the required total width.

- c) **Sprinkler concession.** Where the *firecell* is sprinklered it is unnecessary to provide extra width to allow for the possibility that one *escape route* may be unusable.

- d) **Horizontal escape routes.** A horizontal *escape route* which has a single direction of escape shall be wide enough at any point to take the full *occupant load* from all contributing *occupied spaces*, but the *escape route* may have its width progressively increased as it passes the exit from each *occupied space* (see Figure 3.4).
- e) A horizontal *escape route* with two directions of escape, shall, for its full length, have sufficient width to allow for the *occupant load* from all contributing spaces. This shall not apply where Paragraph 3.9.12 e) applies for escape through adjacent *firecells*.
- f) **Intermediate floors.** In *firecells* containing *intermediate floors*, both the vertical and horizontal parts of the *open path escape route* shall be wide enough to take the full *occupant load* from all contributing spaces.
- g) **Vertical safe paths.** Vertical *safe paths* serving *firecells* at more than one level shall have minimum widths at any point determined only by the largest total *occupant load* from any level passing that point in the direction of escape.

COMMENT:

It is not necessary to provide for cumulative *occupant load* as the *escape route* passes each floor level.

- h) **Wharenui.** In *wharenui* where the *surface finishes* of the interior walls do not comply with Paragraphs 6.20.1 to 6.20.7, the *escape route* widths required by Table 3.2 shall be doubled.
- i) **Basements.** Where an *escape route* from upper floors is joined at the level of a *final exit* by an *escape route* from a *basement* or lower floors, the *escape route* width at the point they combine shall be increased to accommodate the *occupant loads* from both directions (see Figure 3.5).
- j) **Ladders.** The width requirements of Table 3.2 do not apply to ladders (see Paragraph 3.10.2).
- k) **Fixed or loose seating.** The width requirements of Table 3.2 do not apply to fixed or loose seating (see Paragraphs 3.9.3 and 3.9.10).

Figure 3.3: Exitway Widths in Unsprinklered Firecells
Paragraph 3.3.2 b)

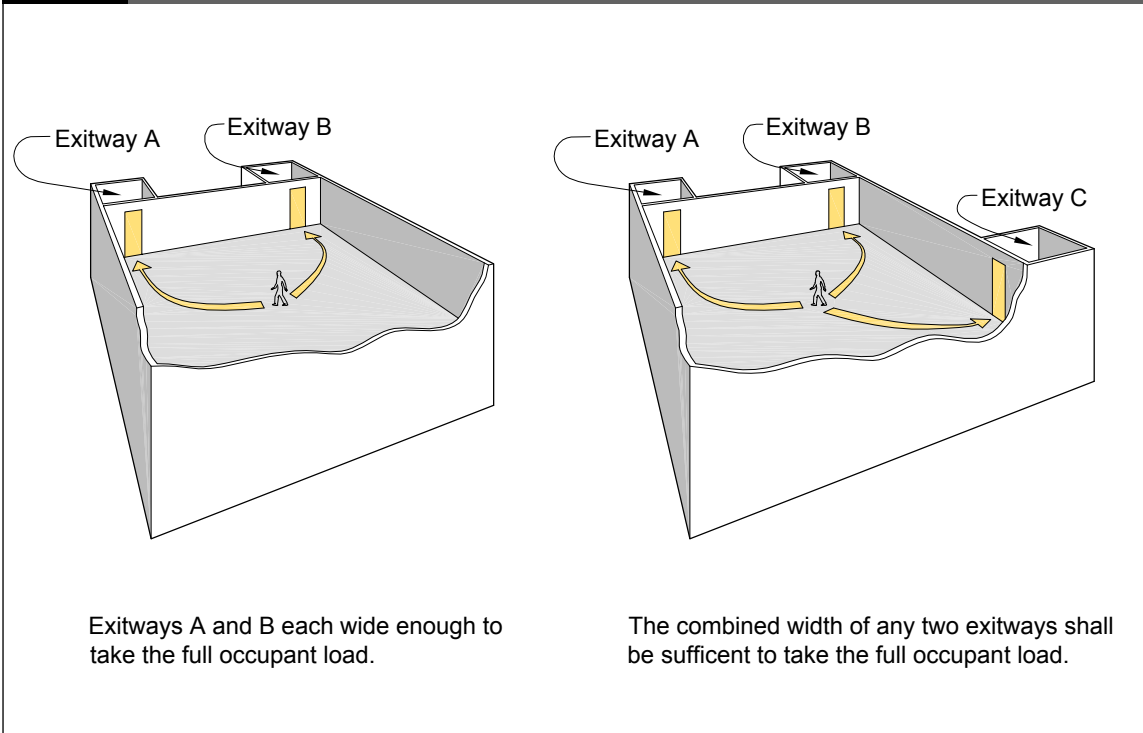

Figure 3.4: Increase in Width for Horizontal Escape Routes Having a Single Direction of Escape
Paragraph 3.3.2 d)

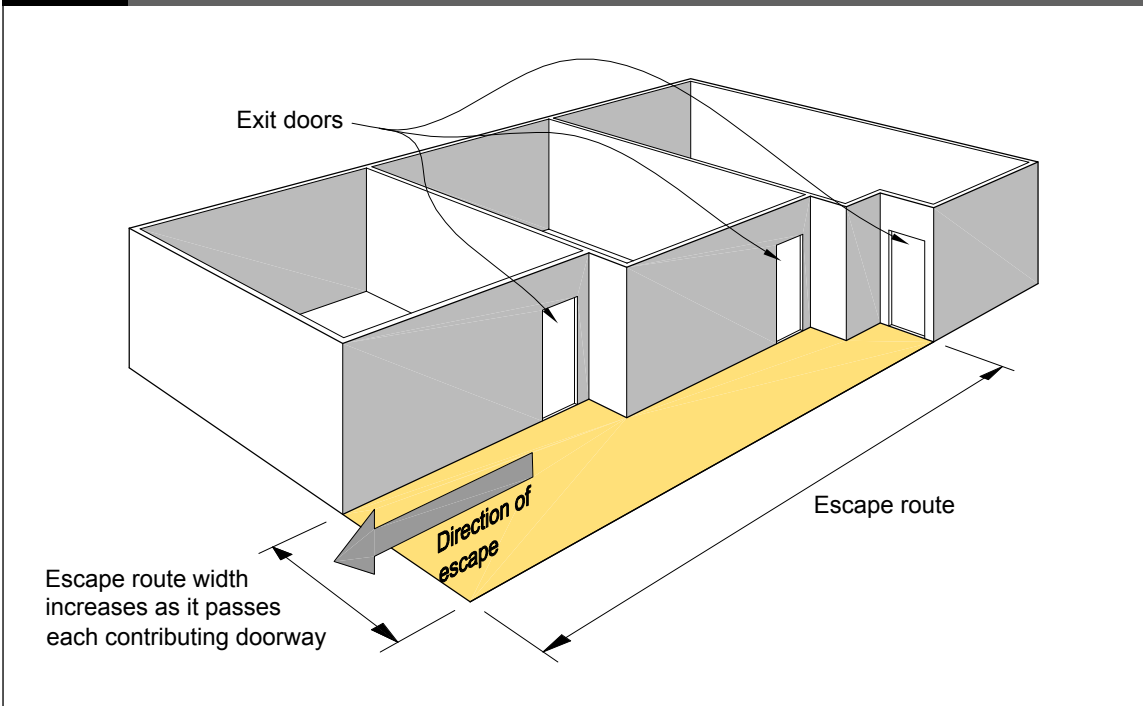
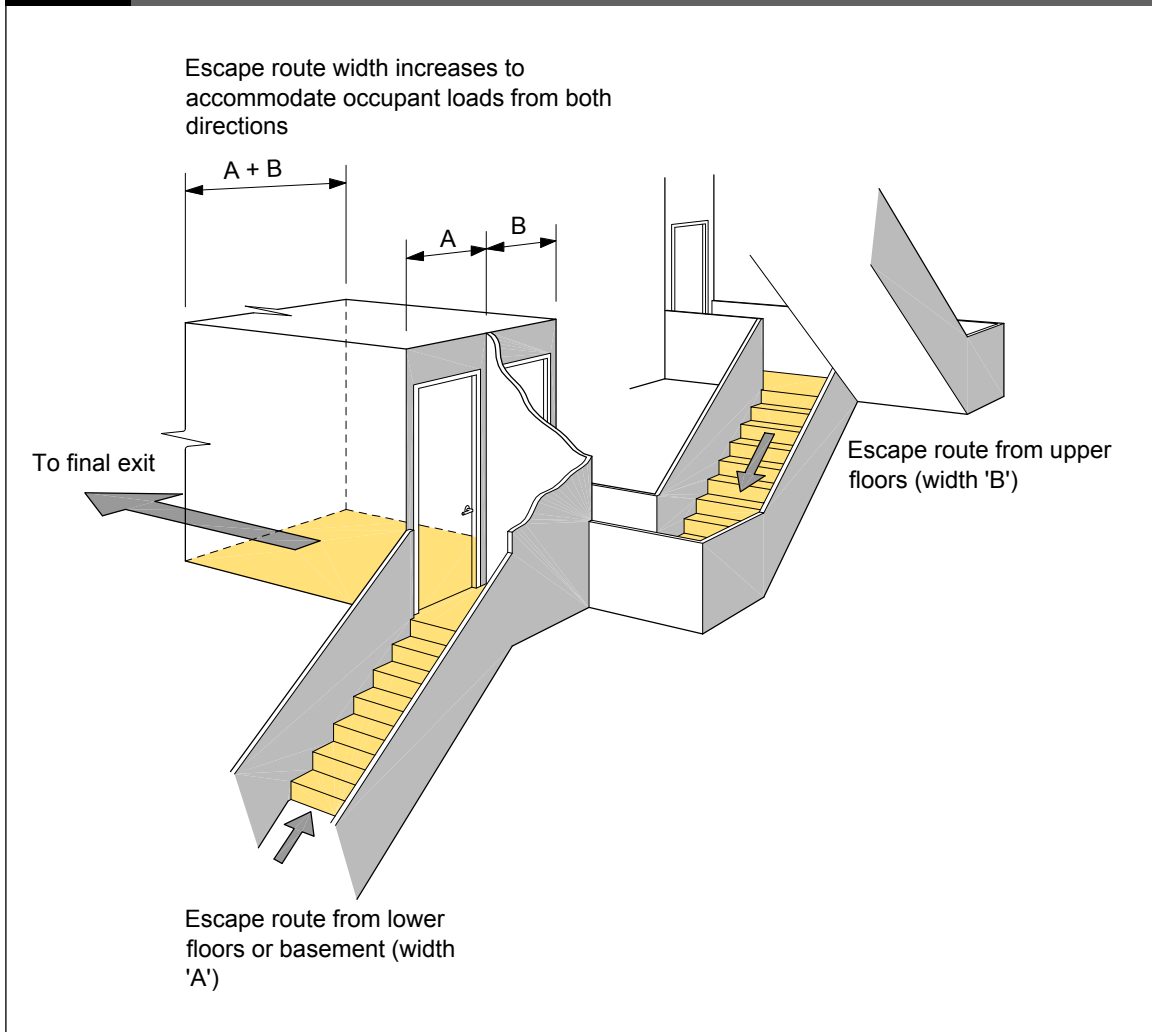

Figure 3.5: Escape Routes from Lower and Upper Floors
Paragraph 3.3.2 i)



Handrails and limitations to stair widths

3.3.3 For safe evacuation on stairs:

- Stairways in escape routes wider than 1500 mm shall have *handrails* on both sides.
- Stairways in escape routes wider than 2000 mm (see Figure 3.6) shall be provided with intermediate *handrails*, equally spaced, and providing a width not greater than 1500 mm for each section of the *stairway*.

COMMENT:

D1/AS1 Paragraph 6.0, requires all *stairways* to have at least one *handrail*, and for *accessible stairs*, *handrails* are required on both sides.

3.3.4 Where the *escape height* exceeds 34 m, no more than 1500 mm shall be credited to the width of any *stairway* in an *escape route*.

COMMENT:

- Stairway* width may be more than 1500 mm, but for the calculation of stair capacity, not more than 1500 mm may be used.
- This may require the provision of additional *exitways* to carry the *occupant load*, which allows for a more orderly evacuation than might occur with people trying in panic to pass one another on a wider *stairway*.

Figure 3.6: Limitations to Stair Widths
Paragraph 3.3.3 b)

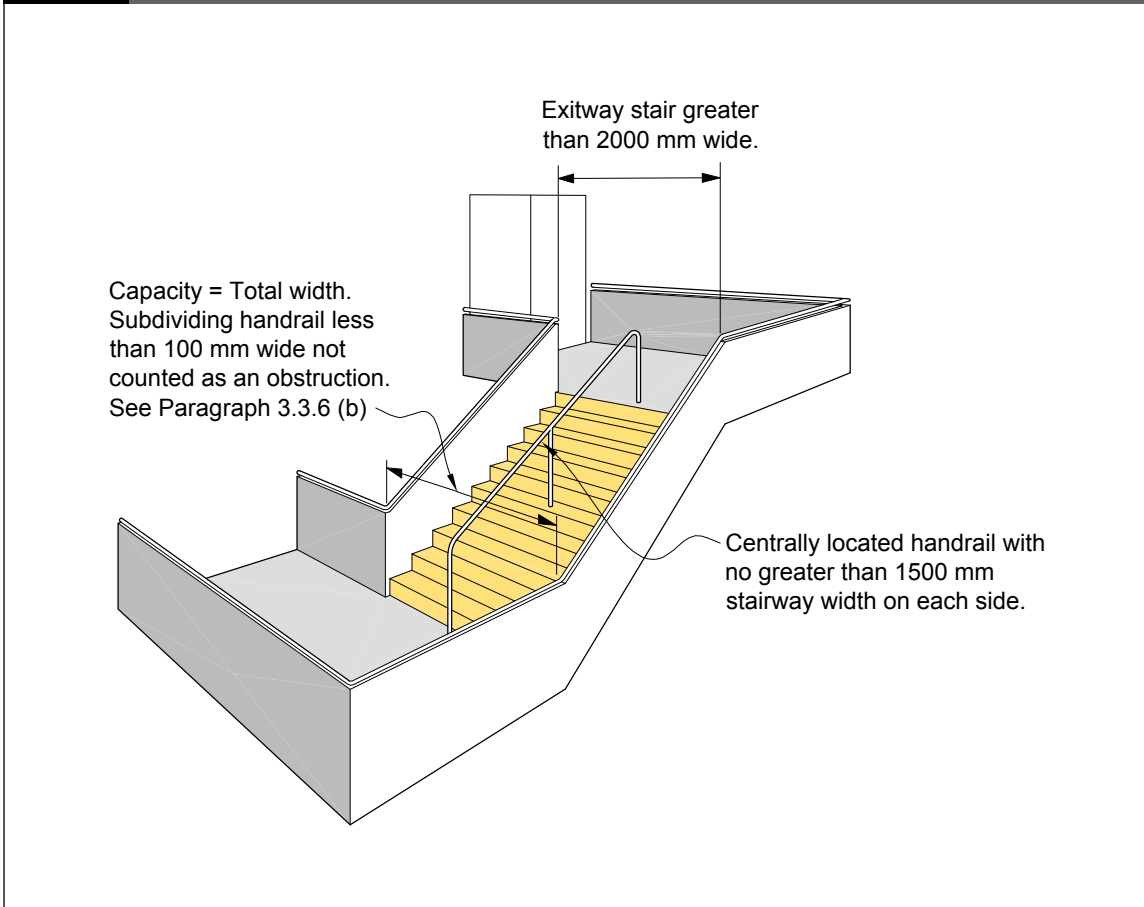

Curved and spiral stairs

3.3.5 Where curved or spiral stairs form part of an *escape route*, the required width shall be that described as “walking area” in D1/AS1 Figure 17.

Obstructions

3.3.6 Except as permitted by Paragraph 3.17.7, *escape routes* shall not be obstructed by access control systems such as revolving or automatic sliding doors, chains, turnstiles, sliding bars, crowd control barriers and similar devices.

The following minor obstructions are acceptable within the width of an *escape route*.

- a) **Minor projections** complying with the requirements of D1/AS1 such as signs,

switches, alarm sounders and similar projections.

- b) *Handrails* complying with D1/AS1, projecting not more than 100 mm into the width, and *handrails* subdividing wide *stairways*, that reduce the width by no more than 100 mm (see Paragraph 3.3.3).

COMMENT:

1. The term “clear width” as used in D1/AS1 has the same meaning as the word “width” in this acceptable solution (including Table 3.2). This means that where *handrails* are used on both sides of an *exitway* having a “width” of 1000 mm, the measured width between faces of the *handrails* must be no less than 800 mm.
2. For *accessible* and common *stairways*, D1/AS1 requires the width between faces of the *handrails* to be no less than 900 mm, however, this is not necessary in vertical *safe paths* where refuge areas are provided.

- c) **Fixed seating** (at the start of an *escape route*) which complies with the requirements of Paragraph 3.9.3 and Table 3.4 for the width of aisles and space between rows.
- d) **Windows** complying with the special conditions of Paragraph 3.18 for use as part of an *escape route*.
- e) **Door assemblies** which reduce the width of an *exitway* by no more than 125 mm when the door is fully open (see Figure 3.25).

COMMENT:

The measured width with the door open must be no less than the required *exitway* width minus 125 mm, this allowance is for projecting parts of the door frame assembly, the thickness of the door when open and similar acceptable obstructions.

Accessible escape routes

3.3.7 Where an *accessible route* is also used as an *escape route*, the width shall be no less than required by D1/AS1 for *accessible routes*. However, any part of the *open path*, not required to be an *accessible route* for normal daily activities, shall have a minimum width of 850 mm, and any doors on the *escape route* shall open in the direction of escape.

COMMENT:

1. Paragraph 3.17.5 already requires a minimum door opening width of 760 mm on *open paths*.
2. The minimum 1200 mm width for *accessible routes*, as given in D1/AS1, assumes sufficient width for an ambulant *person* to pass a *person* in a wheelchair. It is assumed that all people will be travelling in the same direction during an evacuation and passing provision is not necessary.
3. The minimum width of an *escape route* within an *exitway* is 1000 mm (Paragraph 3.3.2 a)). However, the minimum width is 1200 mm where that *exitway* is required to be an *accessible route* for normal daily activities.

3.4 Length of Escape Routes

3.4.1 An *escape route* may be any length, but:

- a) The lengths of *dead ends*, total *open paths* and *protected paths* shall not exceed

those permitted by Table 3.3, adjusted as necessary for:

- i) reductions on *intermediate floors* (see Paragraph 3.4.6),
- ii) reductions on stairs and ladders (see Paragraph 3.4.7),
- iii) increases allowed for *fire safety precautions* (see Paragraph 3.5), and

COMMENT:

Table 3.3 limits the *dead end* length to 24 m in *purpose group* SH. This means that in large two floor, or in three floor detached dwellings, it may be necessary to have two means of escape or install a *fire safety precaution* which permits an increase in *open path* length allowed by Paragraph 3.5.

- b) Where the distance to the *final exit* exceeds the allowable combined length for total *open path* plus *protected path*, the remainder of the *escape route* shall be a *safe path*. (See Paragraph 3.11.7 for *safe path* length restrictions within a single floor level.)

Open paths

3.4.2 When determining *open path* lengths, including the *dead end*:

- a) **Start point.** The length is measured from no more than 1.0 m from the most remote point in a space.
- b) **Multiple purpose groups.** The lengths in Table 3.3 apply to specific *purpose groups*. When different *purpose groups*, having different allowable maximum *open path* lengths use the same *open path*, the *purpose group* with the shortest maximum length shall apply.
- c) **Furniture/fittings.** Allowance shall be made for the *travel distance* around obstructions such as furniture, fittings and office equipment located in the *open path* (see Figure 3.7).
- d) **Multiple escape routes.** Where two or more *escape routes* are required, *open path* lengths from any point on a floor to no fewer than two exits from the *firecell* shall not exceed the lengths given in Table 3.3.

- e) **Wharenui.** In *wharenui* where the *surface finishes* of the interior walls do not comply with the requirements of Paragraphs 6.20.1 to 6.20.7, the permitted length of the *open path* shown in Table 3.3 shall be halved.
- f) **Termination.** An *open path* ends at:
 - i) the start of an *exitway*, or
 - ii) at a *final exit*, or
 - iii) where the *escape route* passes into an adjacent *firecell* on the same level (see Paragraphs 3.9.12 and 3.9.13).

COMMENT:

Circumstances allowing increases in *open path* length are given in Paragraph 3.5, and other *open path* requirements are given in Paragraph 3.8.

Protected paths

3.4.3 In unsprinklered *firecells*, where a *protected path* enters a vertical *safe path* it shall have sufficient capacity to serve as a holding area for occupants who may be delayed by the movement of occupants from other levels using the *safe path*. (See Paragraphs 3.11.1 to 3.11.3 for additional *protected path* requirements.)

COMMENT:

1. A holding area is not required for occupants of the highest level served by a descending vertical *safe path*, or the lowest level served by an ascending vertical *safe path*.
2. The following is an abbreviated list of situations where *protected paths* are mandatory regardless of *open path* length. Users should always refer to the relevant quoted paragraph before finalising requirements for a specific project.

Figure 3.7: Length of Open Paths
Paragraph 3.4.2 c)

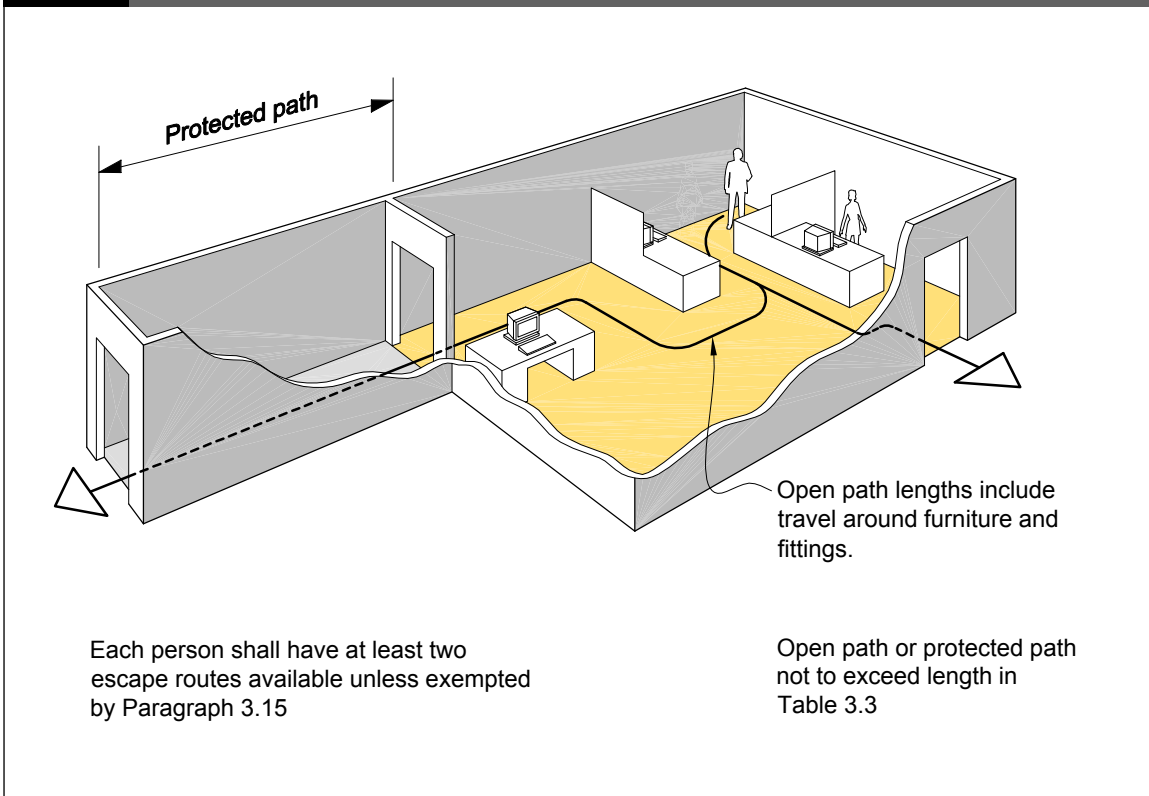

	Reference Paragraph
Escape through an adjoining <i>building</i>	3.6.1 b)
Escape from <i>basements</i>	3.7.1 a)
Single <i>escape routes</i> serving two or more floors in active <i>purpose groups</i>	3.15.3 b)
Entrance to vertical <i>safe paths</i> for CL <i>purpose group</i> in particular situations	3.16.3
Entry from enclosed car park	6.10.4 a)
Internal access to plant rooms	6.11.3 b)

3.4.4 Any increase in *open path* length permitted (by Paragraph 3.5) for *fire safety precautions*, does not apply to *protected paths*. However, where the total *open path* length is less than the maximum permitted by Table 3.3, the difference between actual and permitted length may be added to the *protected path* length.

Protected path floor area

3.4.5 The floor area of a *protected path* preceding a vertical *safe path* (see Figure 3.8) shall be calculated for the *occupant load* using that *protected path* by assuming that:

- a) Part of the *occupant load* will be accommodated in the *stairway* vertical *safe path* between the level being considered and the next level in the direction of escape, with the remaining occupants accommodated in the *protected path*, and
- b) The occupant density for calculating the required holding area is 4.0 *persons* per m². In the *stairway* the floor area shall be taken as the area of the first landing, plus the plan area of the flights of stairs between the two floor levels, plus the areas of any intermediate landings. Additional space shall be provided for door swings.

COMMENT:

This paragraph does not call up a requirement for a *protected path*, but when they are required by other parts of the acceptable solutions, this paragraph states how *protected paths* are to be sized.

Figure 3.8: Protected Paths Preceding Vertical Safe Paths
Paragraph 3.4.5

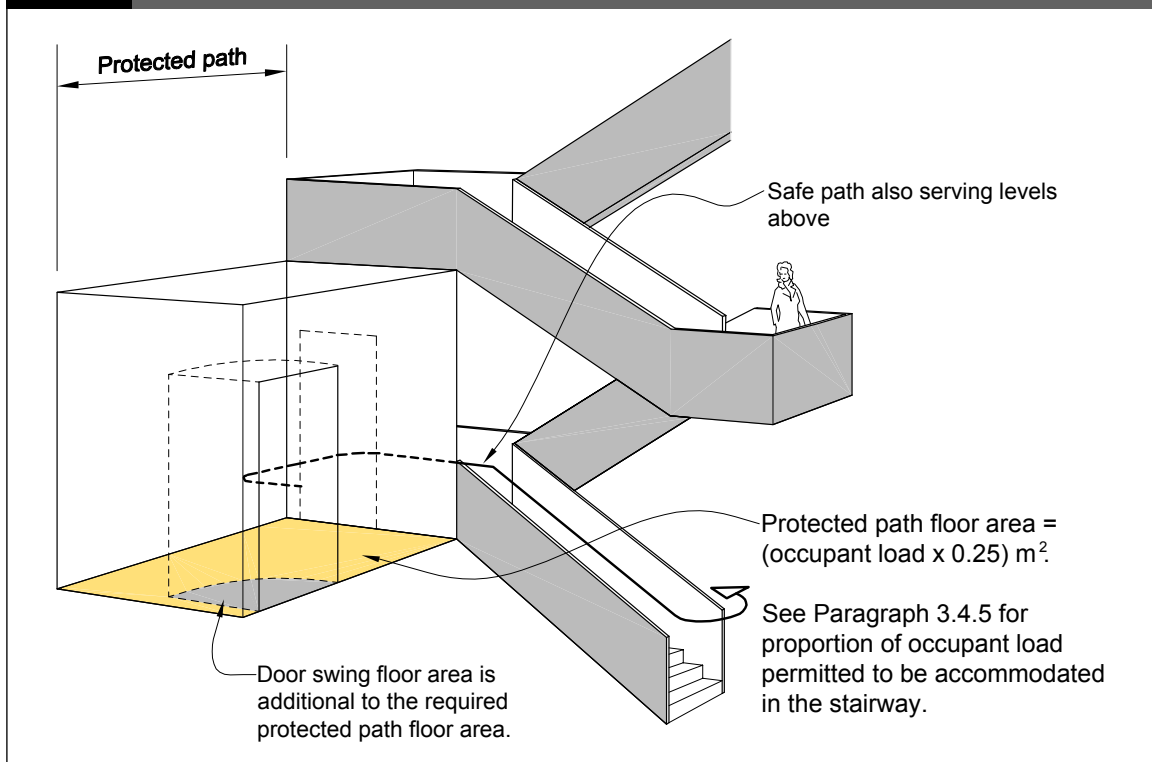

Intermediate floors

3.4.6 On *intermediate floors* (see Figure 3.9) the *open path* length, for compliance with Table 3.3, shall be taken as 1.5 times the measured length. However, the measured length may be used where either of the following conditions apply:

- a) A smoke control system (*fire safety precaution* Type 10 or Type 11) protecting the occupants of the *intermediate floor* is present, or
- b) The *intermediate floor* is a *smokecell* and an *escape route* is available from the

intermediate floor without passing through any lower space in the same *firecell*.

COMMENT:

1. People on an *intermediate floor* may be exposed to smoke at an earlier stage than people on a full floor. Reduced *open path travel distances* mean reduced exposure time to smoke from the *fire*.
2. The definition of *intermediate floor* excludes upper floors within *household units* of *purpose groups* SR and SH, therefore measured *open path* lengths may be used.

Figure 3.9: Intermediate Floor Open Path Length
Paragraphs 3.4.6 and 3.4.7

Dead end route on intermediate floor assessed as 1.5 x measured length.

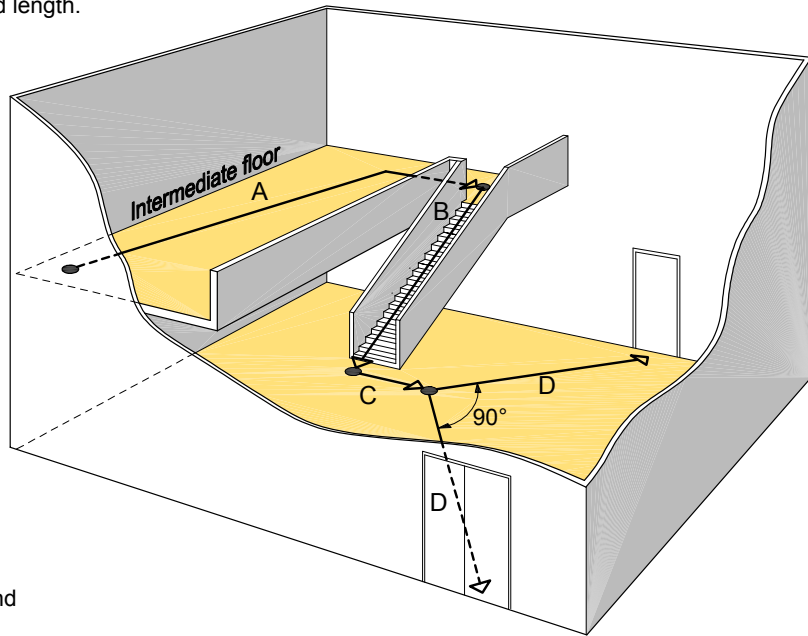

A = 1.5 x measured length.
B = stair pitch line length.
A + B + C must not exceed maximum permitted dead end length.

A + B + C + D must not exceed maximum permitted total open path length

Stairs and ladders

3.4.7 Stairs and ladders occurring in an *open path* (see Figures 3.9 and 3.10) shall have their *open path* length taken as:

- a) For **straight and curved stairs**: the length of the *pitch line* measured on the stair centreline, plus the plan length of each landing.
- b) For **spiral stairs**: twice the vertical height.

- c) For **ladders**: three times the vertical height.

COMMENT:

It is acceptable to use two spiral stairs as part of the *escape routes* from such situations as an *intermediate floor* down to the *firecell floor*. Likewise, where ladders are permitted to serve such situations as the fly-tower of a *theatre*, or maintenance platforms in industrial plant, two ladders may be used as the *escape routes*.

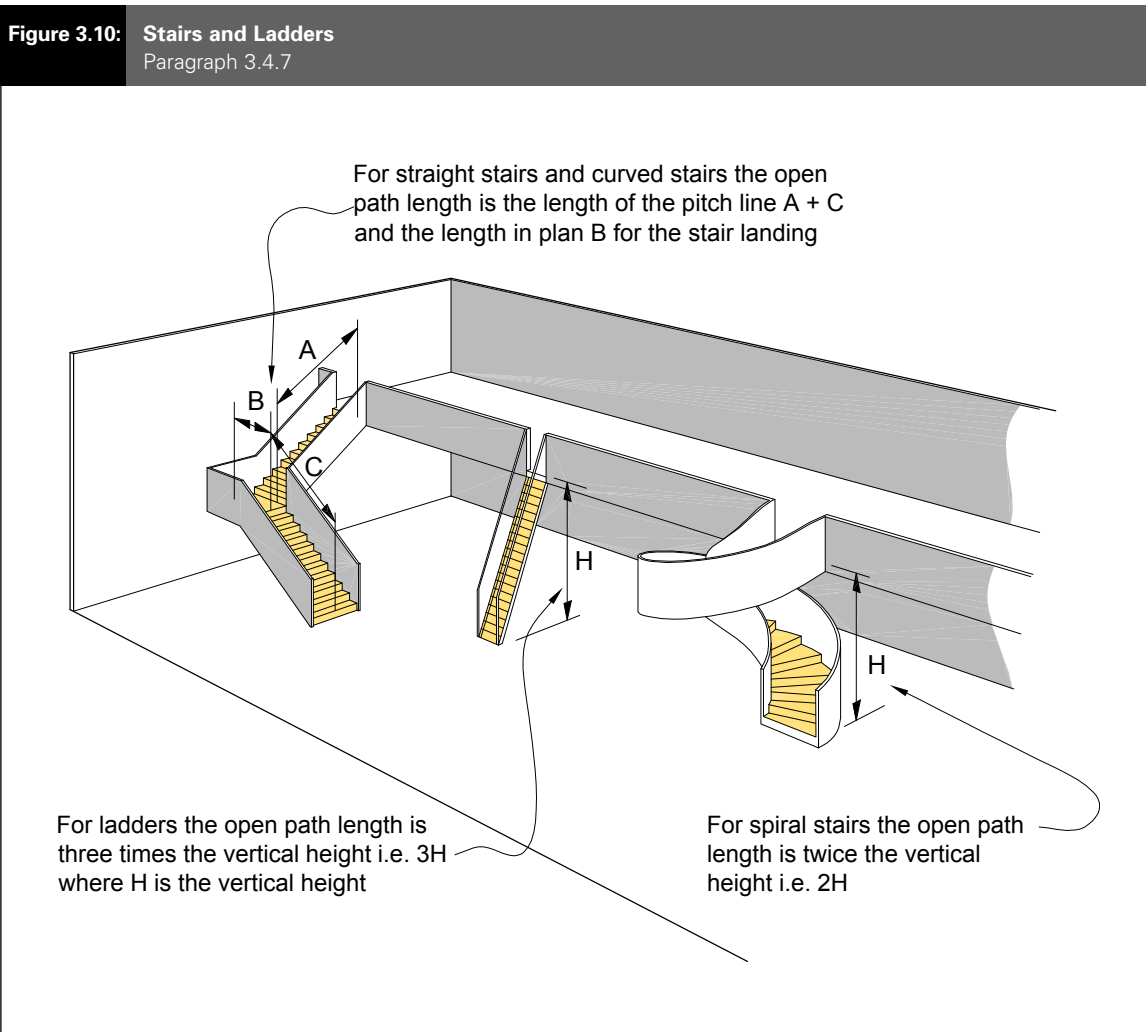

Sloping floors and ceilings

3.4.8 The *open path* length permitted by Table 3.3 shall be reduced by 50% in any space where all the following conditions apply:

- a) Both the floor and the ceiling slope in the same direction at an angle of more than 4° from the horizontal, and any *escape route* from the space is up the slope, and
- b) The clear ceiling height at any point is less than 4.0 m, and
- c) The *occupant load* in the space is more than 50, and
- d) The space is not protected by a smoke control system (*fire safety precaution* Type 10 or Type 11), or by a sprinkler system.

COMMENT:

People in a space with a sloping floor and ceiling will be exposed to smoke at an earlier stage than people in a space with a flat ceiling. This is potentially a problem when the direction of escape is up the slope. Reduced *travel distances* mean reduced exposure time to the smoke from the *fire*.

3.5 Acceptable Increases in Open Path Lengths

3.5.1 *Dead end* and total *open path* lengths from Table 3.3 may be increased in accordance with Paragraphs 3.5.2 to 3.5.6.

COMMENT:

For *purpose groups* SC and SD, Table 3.3 already includes the permitted increases resulting from the mandatory requirement for smoke detectors and sprinklers, so no further increases are allowed for these *purpose groups*.

Sprinklers

3.5.2 Where the *firecell* is protected by a sprinkler system, (*fire safety precaution* Type 6 or 7), *open path* lengths given in Table 3.3 may be increased by:

- a) 100% for *purpose groups* WL, WM, WH, WF, CS, CL, CM, IA and ID, and
- b) 50% for *purpose groups* SA, SR and SH.

COMMENT:

This applies whatever the reason for use of a sprinkler system. For the purposes of means of escape, sprinklers are not regarded as providing absolute protection, as they operate only after the *fire* has reached a certain intensity, by which time the *fire* can have produced significant quantities of smoke. They are therefore regarded as providing only a *fire* development delay factor, which enables more time for escape.

Heat detectors

3.5.3 Where the *firecell* is protected by heat detectors (*fire safety precaution* Type 3) complying with F7/AS1, *open path* lengths given in Table 3.3 may be increased by:

- a) 20% for *purpose groups* WL, WM, WH, CS, CL, CM, IA and ID, and
- b) 10% for *purpose groups* SA, SR and SH.

COMMENT:

No increase is permitted for WF *purpose group*.

Smoke detectors

3.5.4 Where the *firecell* is protected by smoke detectors (*fire safety precautions* Type 4, 5 or 7) complying with F7/AS1 and subject to *compliance schedule* requirements, *open path* lengths given in Table 3.3 may be increased by:

- a) 100% for *purpose groups* WL, WM, WH, IA and ID, CM, CS and CL (excluding *early childhood centres*), and
- b) 50% for *purpose groups* SA, SR and SH.

COMMENT:

No increase is permitted for SC, SD or WF *purpose groups* or in *early childhood centres*.

Amend 4
Oct 2005

Amend 4
Oct 2005

3.5.5 If *open path* length increases for smoke detectors are being applied, where F7/AS1 allows heat detectors to be substituted for smoke detectors, not less than 70% of the *firecell* shall be protected with smoke detectors, including all sleeping areas and *exitways*.

Combination of increases

3.5.6 The increases allowed in Paragraphs 3.5.2 to 3.5.5 shall be calculated separately, and may be combined provided the total length of the *open path* (including the *dead end*) is no greater than:

- a) Twice that given in Table 3.3, or
- b) Two and a half times that given in Table 3.3 where the *firecell* floor area is greater than 400 m² for *purpose groups* IA and ID, or
- c) Three times that given in Table 3.3 where the *firecell* floor area is greater than 400 m² for *purpose groups* WL, WM, WH, CS, CL and CM.

3.6 Escape Through Adjoining Building

3.6.1 An *escape route* may be via an adjoining *building* (see Figure 3.11), provided all the following conditions are satisfied:

- a) The *escape route* through the adjoining *building* meets all *escape route* requirements for the *occupant load* from the *fire* affected *building*, requiring to use that route.

COMMENT:

It is not necessary for the *escape route* to be wide enough to carry the combined *occupant load* from both *buildings*.

- b) Unless the *escape route* passes directly to a *safe path* in the adjoining *building*, access shall be through a *protected path* before passing through the *external walls*.
- c) The opening through the *external wall* having the higher *FRR*, has a *fire door* with a *FRR* of no less than that wall.
- d) *Escape routes* in the adjoining *building* comply with the New Zealand Building Code and have sufficient capacity to carry the *occupant load* from the *building* or *buildings* being evacuated.

- e) The *escape route* does not re-enter the first *building* at any point, and is freely available at all times.

COMMENT:

1. An *escape route* of this type depends on a permanently-binding legal agreement between different *owners*, tenants, or occupiers.
2. If the *escape routes* in the adjoining *building* comply with this acceptable solution they shall have sufficient capacity to provide for the maximum number of occupants in any *firecell*. Clearly the *escape routes* must be sized for the largest number using them, in either *building*, but not both. This situation should present no great problem when the adjoining *building* is, and will remain, under the same *ownership* or management control as the original *building*. Problems may arise when *ownership*, or management, or use of the adjoining *building* changes, which can and does happen, particularly when the adjoining *building* is an existing *building* or part of it is sold under such arrangements as the Unit Titles Act. In such cases, approval should be dependent on the provision of a legal agreement, and perhaps a caveat on the title, which ensures that the dependence on the means of escape will not be frustrated by subsequent events.

3.7 Escape from Basements

3.7.1 Except where there are two or more *escape routes* serving only the *basement firecells*, and each terminates in a *safe place*, *safe paths* serving *basement firecells* shall be:

- a) Preceded by a *protected path*, and
- b) Pressurised (to comply with AS/NZS 1668: Part 1) when serving more than three levels below the lowest *final exit*.

3.8 Open Paths

Number and size

3.8.1 *Open paths* shall comply with the requirements of Paragraphs 3.2 and 3.3 for *escape routes* with respect to number, height and width, and with Table 3.3 for length.

3.8.2 In addition, *open paths* shall satisfy the specific requirements of Paragraphs 3.8.3 to 3.9.14 where they apply to a particular *building*.

Figure 3.11: Escape Through Adjoining Building
Paragraphs 3.6.1 and 3.17.13 c)

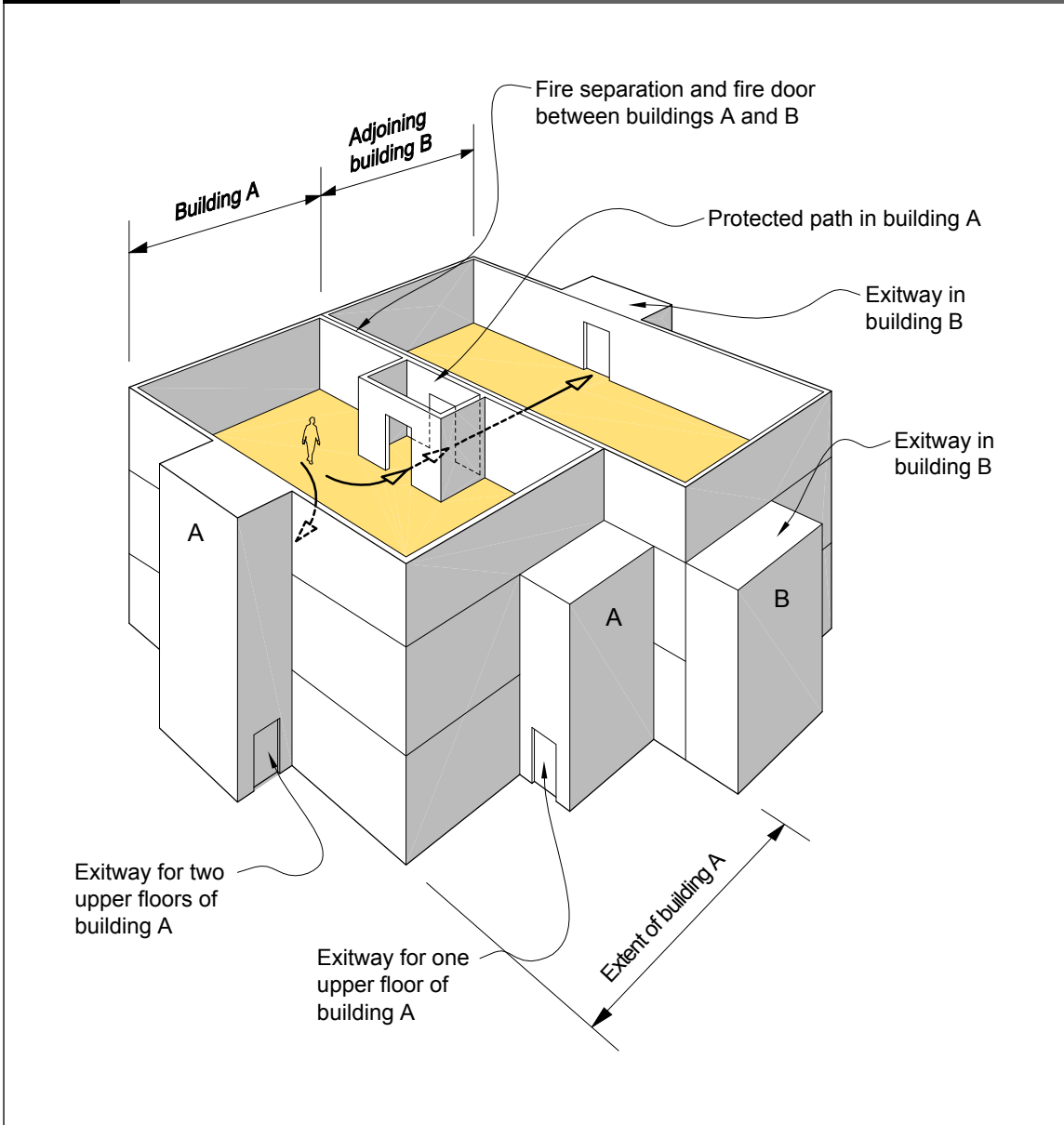

Open path separation

3.8.3 Where two or more *open paths* are required, they shall be separated from each other, and remain separated until reaching an *exitway* or *final exit* (see Figure 3.12). Separation shall be achieved by diverging (from the point where two *escape routes* are required), at an angle no less than 90° until separated by:

- a) A distance of at least 8.0 m, or
- b) *Smoke separations* and *smoke control doors*.

COMMENT:

If this separation or protection is not observed, the length of the *open path* is limited to that of a *dead end*. This is critical in planning single *stairway buildings* as the *stairway* must be positioned within the *dead end travel distance* limits.

Figure 3.12: Alternative Open Path Separation
Paragraph 3.8.3

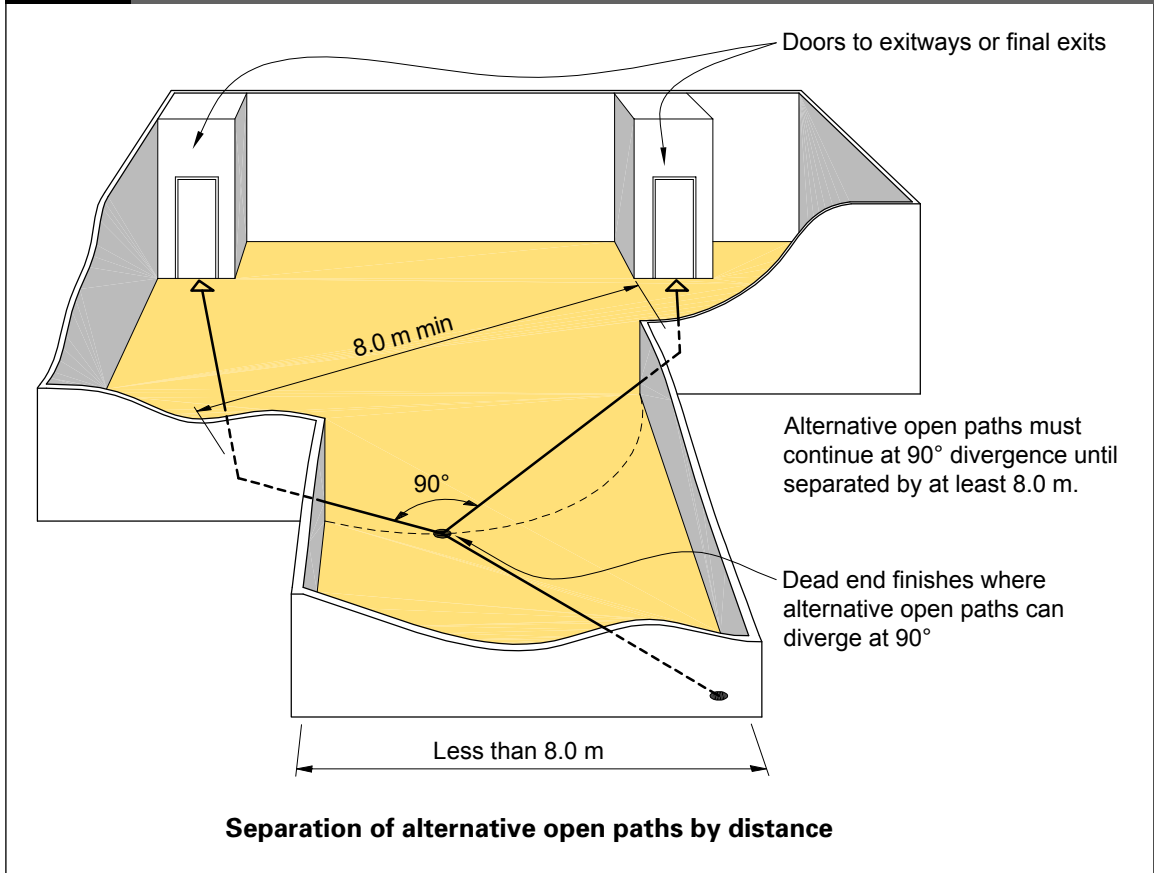

Exception for education buildings

3.8.4 Where a *building* houses classrooms, laboratories and spaces used for home economics, art and crafts, workshops or similar teaching activities, one *open path* may be via a connecting corridor, and the alternative *open path* via connecting doors between *adjacent* teaching spaces. In such a case the separation requirements of Paragraph 3.8.3 need not apply provided that:

- The number of occupants in each teaching space does not exceed 100, and
- The *escape route* does not pass through a space which may be locked.

3.9 Special Cases of Open Paths

Separate tenancy

3.9.1 *Open paths* may pass through spaces containing different tenancies only if doors leading to an *exitway* or *final exit* may be readily opened by all *persons* for whom the *open path* is their *escape route*.

Ramps

3.9.2 Where stairs are not used, changes in level on an *escape route* shall be formed as ramps and comply with D1/AS1.

Fixed seating

3.9.3 Fixed seating shall be arranged so that:

- a) Direct access to the aisles is available,
- b) The number of seats in a row is no greater than allowed by Table 3.4 (which permits seat numbers to be doubled for *purpose group CO*),
- c) The clear walkway between rows is no less than given in Table 3.4, and
- d) The area occupied by each seat, and the walkway in front of it, has dimensions of no less than:
 - i) where seat backs are not provided or fold forward when not occupied: 600 mm from back edge to back edge (see Figure 3.13).

- ii) where seat backs are provided: 760 mm from seat back to seat back (see Figure 3.14).
- iii) where arms are provided: 500 mm seat width (see Figure 3.14).
- iv) where arms are not provided: 450 mm seat width (see Figure 3.13).

COMMENT:
The distance between seat backs should be measured horizontally at right angles to the rows of seats.

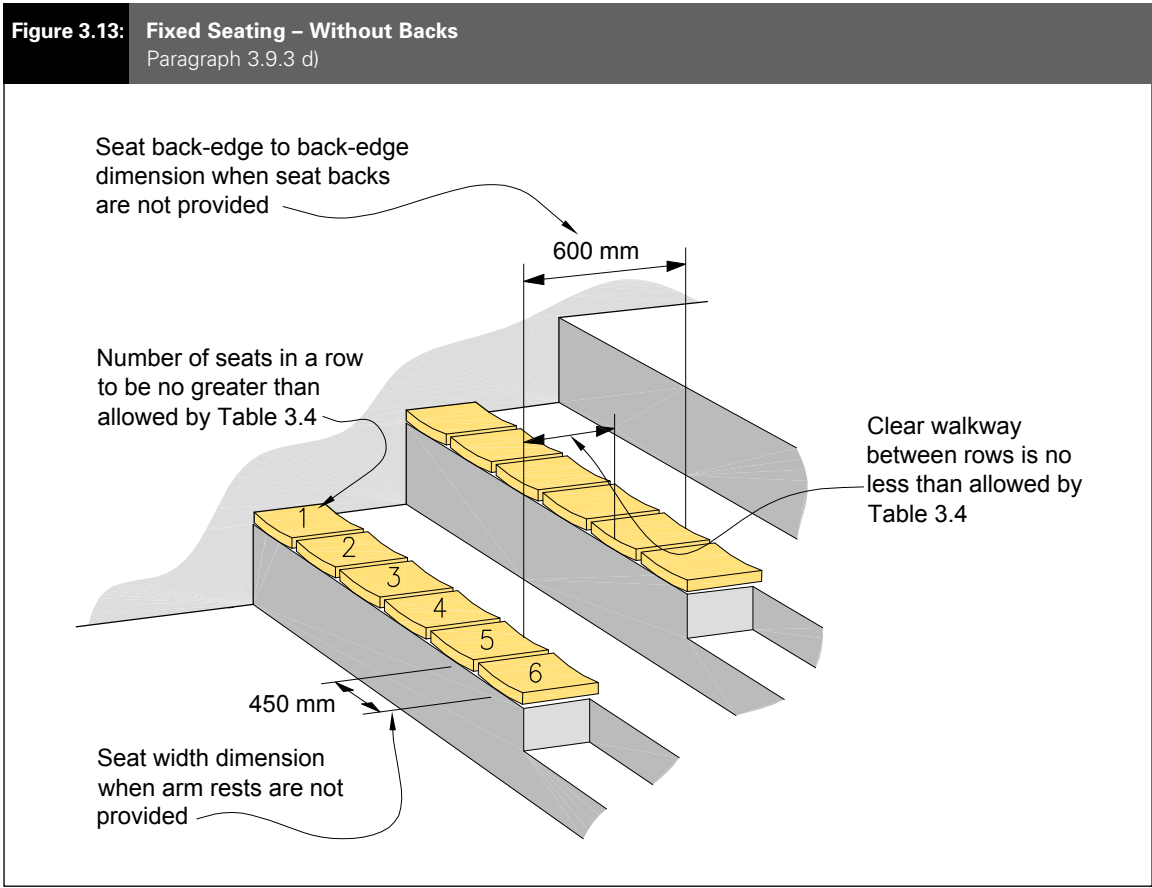
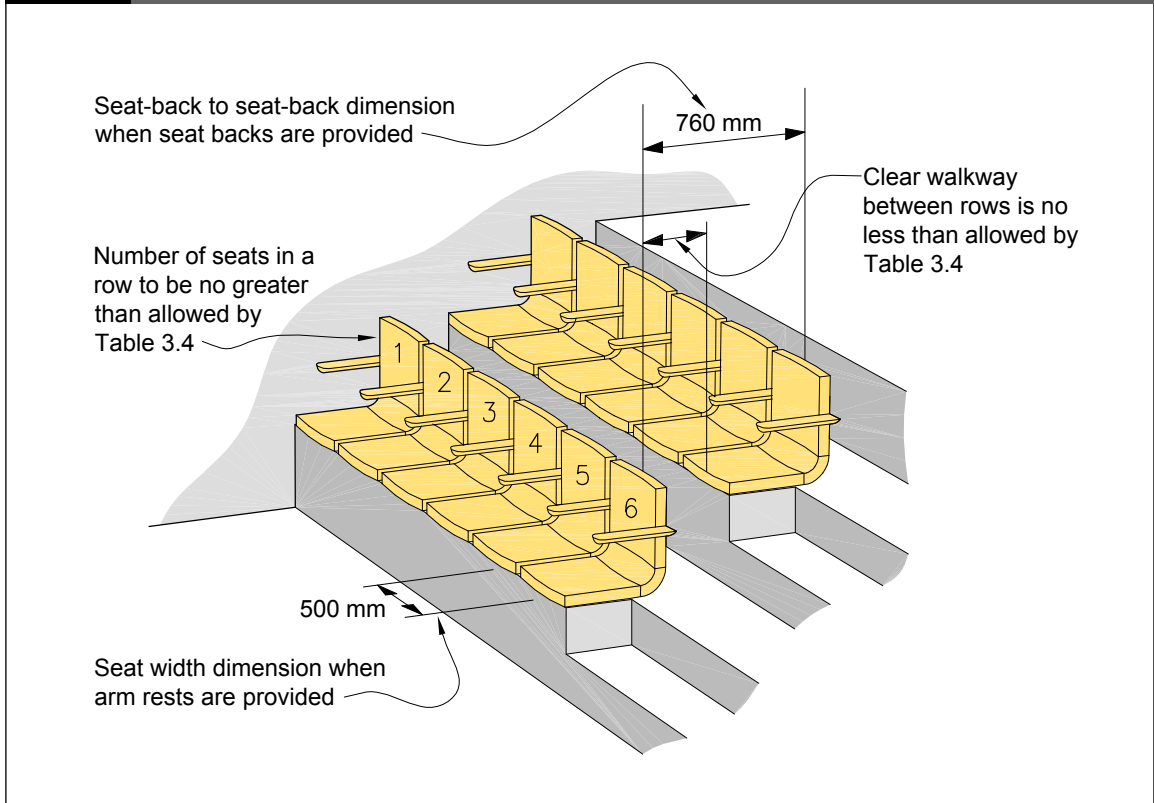

Figure 3.14: Fixed Seating – With Backs
Paragraph 3.9.3 d)



Aisles

3.9.4 Aisles serving fixed or loose seating (see Figure 3.15) shall provide direct access to *final exits*, or *exitways* having a width which is the greater of the aisle width or the width required by Paragraph 3.3.2. Aisle widths shall be no less than:

- a) 750 mm when serving up to 60 seats.
- b) 900 mm when serving over 60 seats on one side only.
- c) 1100 mm in all other cases.

3.9.5 The minimum width shall occur at:

- a) The point furthest from the *exitway* in aisles which discharge in one direction only.

- b) Mid-length of an aisle which discharges in two directions to separate cross-aisles or separate *exitways*.

COMMENT:

There is nothing to prevent an aisle being made wider than the minimum but to avoid restrictions this may be done only in the direction of travel.

3.9.6 Each cross-aisle shall have a width of no less than that of the widest aisle it serves, plus 50% of the sum of the widths of all other aisles served.

3.9.7 The *travel distance* from any seat to a *final exit* or *exitway* shall be no greater than allowed for an *open path* in Table 3.3.

3.9.8 Any side of an aisle, not providing access to seating, shall have barriers complying with F4/AS1 and *handrails* complying with D1/AS1.

Figure 3.15: Aisles Serving Fixed Seating
Paragraph 3.9.4

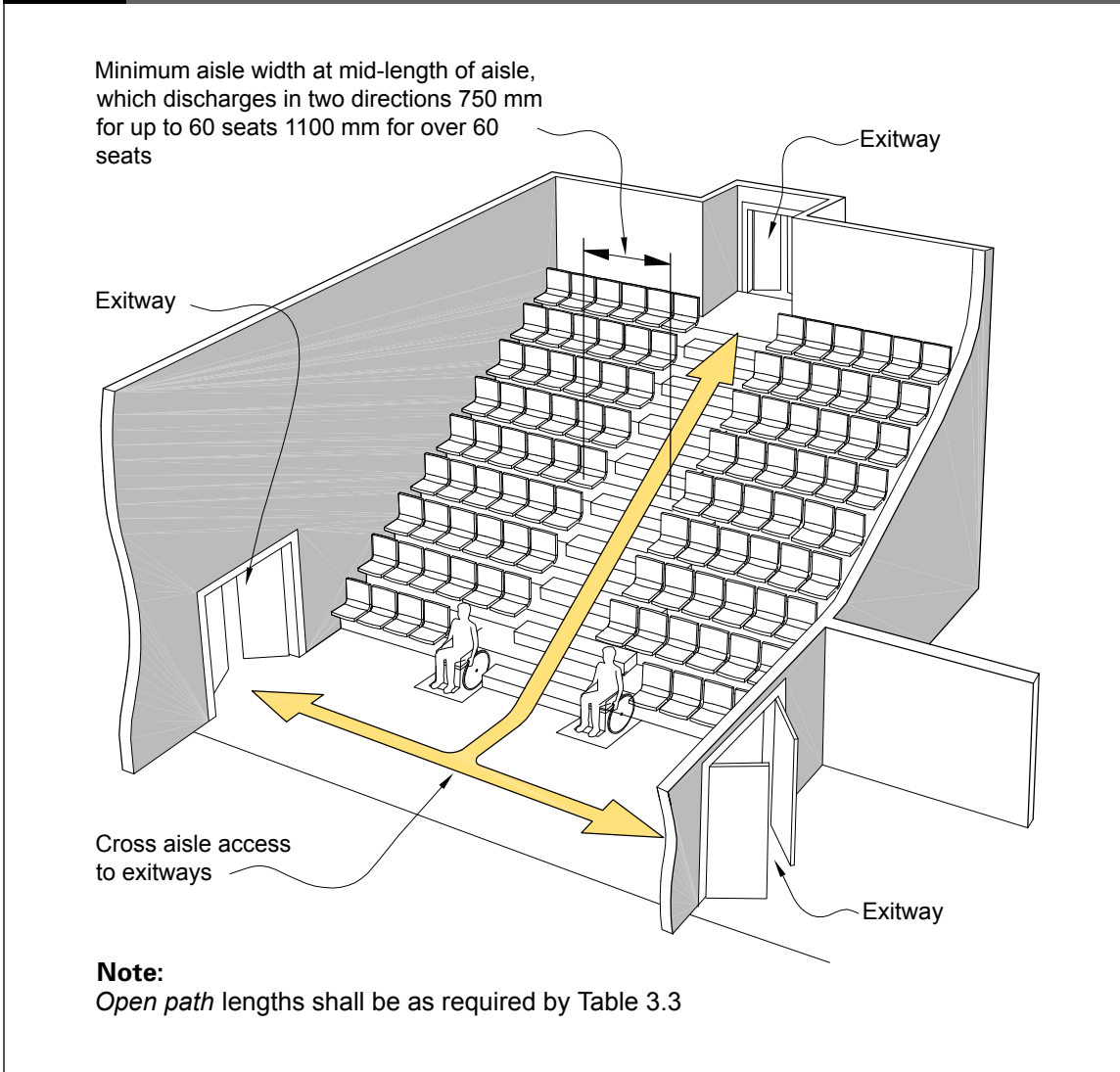

3.9.9 Steps in aisles shall have equal riser heights and equal tread depths, both complying with the requirements of D1/AS1. Landing lengths in aisles shall be equal in each block of seating between cross-aisles, but may be less than the minimum length required by D1/AS1.

COMMENT:

This in effect results in an aisle which has a series of short landings connected by one or more uniform steps.

Loose seating

3.9.10 Loose seating is permitted only on level floors, and the layout shall follow the requirements of Paragraphs 3.9.4 to 3.9.7.

3.9.11 Where the *occupant load* exceeds 250, loose seating shall be interconnected to prevent overturning.

COMMENT:

Generally, seats should be rigidly linked in blocks of at least four seats, and preferably, the block at each end, adjacent to each aisle, should be fastened to the floor. It will assist if aisle widths are clearly marked on the floor.

Passing into an adjacent firecell

3.9.12 An *open path* or *protected path* may pass into an adjacent *firecell* on the same level (see Figure 3.16) and recommence as a new *open path* provided that:

- a) All *firecells* on the *escape route* have no fewer than two directions of escape, separated as required by Paragraph 3.8.3, and
- b) Adjoining *firecells* into which evacuation may take place have a floor area sufficient to accommodate not only their own occupants but also the occupants from the adjoining *firecell*. This shall be calculated on the basis of the *occupant load* of the two *firecells*, and
- c) Each *firecell* has at least one other *escape route* independent of the route into the adjoining *firecell*. This other route may be by way of a *final exit* or via a third *firecell* provided that the exit from that third *firecell* is independent of exits from the other two *firecells*, and

- d) The *escape route* does not pass through more than three *fire separations* before entering an *exitway* or *final exit*, and
- e) The *escape route* width meets the requirements of Table 3.2 for the *firecell* (on the *escape route*) having the greatest *occupant load*, and
- f) In sleeping *purpose groups* SC, SD and SA the *firecells* on the floor directly below the *open path* are sprinklered.

COMMENT:

1. *Open path* lengths in each *firecell* are controlled by the requirements of Paragraph 3.4.2 for that *firecell*.
2. Refer to Paragraph 3.17.3 to determine whether doors between *firecells* need to be hung to swing both ways because escape may be in either direction, and Paragraph 3.17.9 for *hold-open device* requirements.
3. This provision may be used to divide wards in hospitals and similar institutions where occupants are bedridden, and provision is made for beds to be wheeled through into a "holding area". See Paragraph 6.6.3.

Figure 3.16: Open Path Passing into Adjacent Firecells
Paragraphs 3.9.12 and 3.17.13 c)

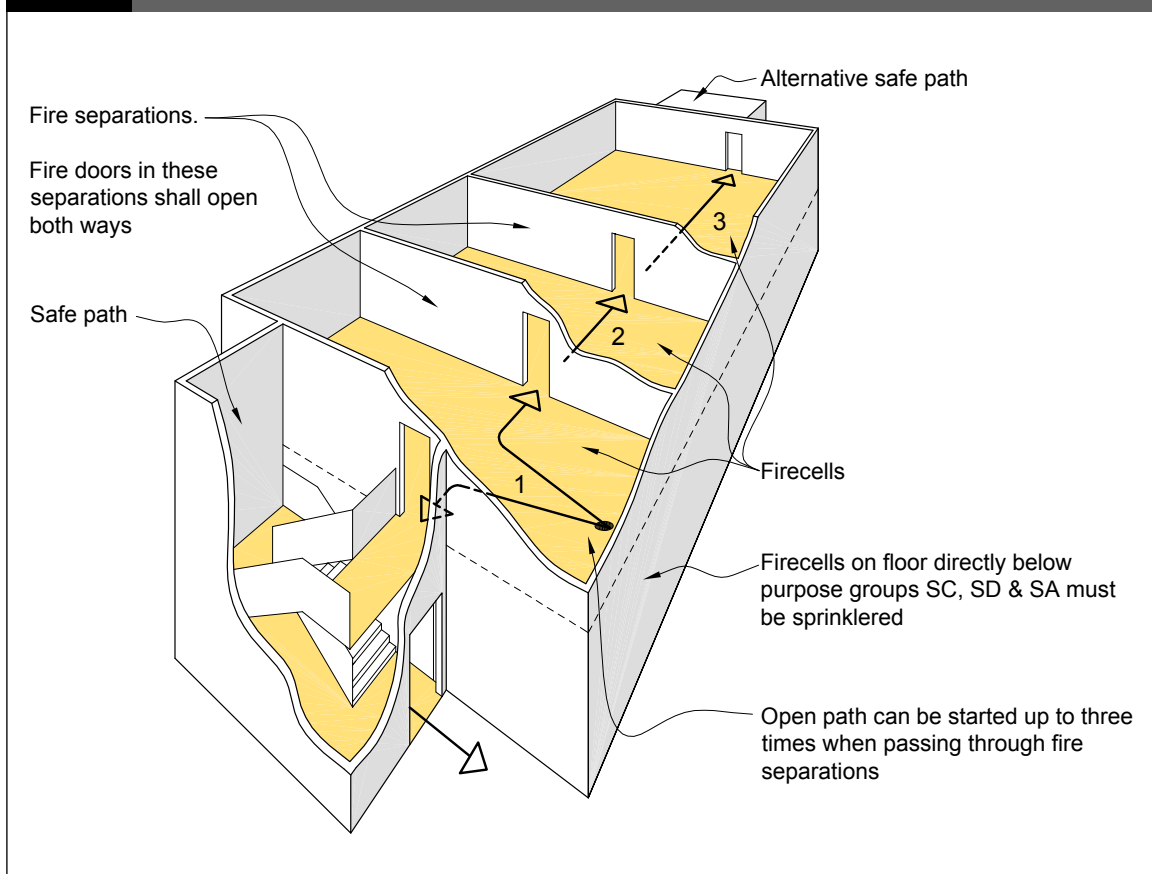

Escape via an intermediate floor

3.9.13 An *open path* or *protected path* may pass from a *firecell* on to an *intermediate floor* and recommence as an *open path* or *protected path* provided that:

- a) Where two or more *escape routes* are required from that *firecell*, only one *escape route* shall be via the *intermediate floor*,
- b) The *intermediate floor* is served by at least two *escape routes*, separated as required by Paragraph 3.8.3, and terminating at separate *firecells*, *exitways* or *final exits* at the same level as the *intermediate floor*,
- c) The *intermediate floor open path* lengths shall not exceed the requirements of Paragraph 3.4.6, and
- d) If there are open *intermediate floors* at two or more levels in the *firecell*:
 - i) barriers shall have no openings, and
 - ii) the *firecell* containing the *intermediate floors* shall be protected by a smoke control system satisfying the requirements of Paragraphs 6.21.5 to 6.22.14.

COMMENT:

This situation often occurs on mezzanine floors and where *occupied spaces* or other *firecells* at different levels open into an atrium space of a larger *firecell*.

Open paths via unenclosed stairs

3.9.14 Unenclosed stairs (stairs which are not smoke or *fire separated* from other spaces), in *escape routes* for *purpose groups* SC, SD and SA shall not exceed a height of 4.0 m within the *firecell*. Where the height exceeds 4.0 m, the *escape route* from that level shall be a *safe path* until it reaches a *final exit*.

3.10 Dead Ends

No more than 50 occupants

3.10.1 A *dead end* shall not serve an *occupant load* greater than 50.

Ladders

3.10.2 The *escape route* from a *dead end* may be a ladder (complying with D1/AS1), where it serves only *purpose group* IA or provides the same function in support of other *purpose groups*, and only if the *occupant load* does not normally exceed 4. Ladders are not permitted as *escape routes* in any other circumstances. (See also Paragraph 3.4.7.)

COMMENT:

The provision is principally for cat-walks used intermittently in industrial plants, fly-towers over stages, and similar situations.-

3.11 Exitways

Protected paths

3.11.1 *Protected paths* shall be separated from each other, and from spaces used for all other purposes, by:

- a) *Smoke separations*, or
- b) *Fire separations* serving as *smoke separations*.

3.11.2 A *protected path* shall serve no more than one *firecell* except where:

- a) Escape through adjacent *firecells* is allowed by Paragraph 3.9.12, or
- b) Escape on an *intermediate floor* is allowed by Paragraph 3.9.13.

3.11.3 Refer to Paragraph 3.4.1 for allowable lengths of *protected paths* and Paragraphs 3.4.3 and 3.4.5 for required floor areas of *protected paths* which precede vertical *safe paths*.

Safe paths

3.11.4 *Escape routes* from *firecells* shall enter directly into a *safe path* or *final exit*, except where Paragraphs 3.9.12 and 3.9.13 permit *open* or *protected paths* to continue from one *firecell* to another.

3.11.5 *Safe paths* shall be separated from each other, and from all spaces used by other *purpose groups* by:

- a) *Fire separations*, or
- b) Where external to the *building*, by distance or appropriate *construction* (see Paragraph 3.14).

3.11.6 Except where the conditions for escape via an external *escape route* (Paragraph 3.14), or successive *open paths* (Paragraph 3.9.12), or an *intermediate floor* (Paragraph 3.9.13) apply, exit doors from sleeping area *firecells* in *purpose groups* SC, SD, SA and *household units* in SR shall open directly onto:

- a) A horizontal *safe path*, or
- b) A pressurised vertical *safe path*, or
- c) A *final exit*.

Safe path length restrictions

3.11.7 There is no limit on the length of a vertical *safe path*. Horizontal *safe paths* shall be no longer than:

- a) The *dead end* length permitted by Table 3.3, where only a single direction of escape is available, or
- b) Three times the total *open path* length permitted by Table 3.3 where two or more directions of escape are available.

The increases permitted by Paragraph 3.5 apply in each case.

Safe path termination

3.11.8 Horizontal *safe paths* shall terminate at any of the following:

- a) The entrance to an internal *stairway* which is a separate *safe path*, or
- b) An external balcony leading to either an open or enclosed *stairway*, or
- c) An opening in an *external wall* which enters on to a bridge leading to an open or enclosed *stairway*, or
- d) A *final exit*.

COMMENT:

1. Long *safe path* corridors may be required to be subdivided by *smoke separations* (see Paragraph 6.13.1).
2. A vertical *safe path* may be required to have mid-height *smoke separation* (see Paragraph 6.9.11).

Safe path separation, glazing and smoke control

3.11.9 The vertical and horizontal portions of internal *safe paths* shall be separated at every floor level by *fire separations* and *fire doors* with smoke control capability.

3.11.10 Glazing in *safe paths* shall comply with the requirements of Paragraphs 5.8.3 to 5.8.7.

3.11.11 Ventilation and smoke control in *safe paths* shall comply with the requirements of Paragraphs 6.9.6 to 6.9.10.

3.12 Control of Exitway Activities

3.12.1 *Exitways* shall not be used for the storage of goods, solid waste or solid waste containers, or for entry points to solid waste chutes.

3.12.2 Other activities are permitted in a *safe path* if:

- a) An alternative *escape route* is available from all *firecells* served by the *safe path* in which the activities occur, and
- b) An alarm system is installed in the *safe path* and connected to alerting devices installed throughout the *building*. (A Type 4 alarm shall be used for *occupant loads* up to 500, and Type 7 for *occupant loads* exceeding 500), and
- c) The *escape route* is not impeded by the other activity or the occupants involved in those other activities, and
- d) Those activities:
 - i) have a *fire hazard category* of no greater than 1, and
 - ii) except in the case of *sanitary fixtures*, are visible to users of the *exitway*, and
 - iii) exist only to provide support functions to the activities of the *purpose group* served by the *exitway*.

COMMENT:

Other activities may include a reception counter, sweet stall, ticket office, toilet facilities etc. Storage of cloaks or linen, a cleaner's cupboard, or an electrical switchboard would not be permitted, and would need to be *fire separated*.

Lifts

3.12.3 A passenger lift, but not a goods lift, may be located in a vertical *safe path* containing a *stairway* provided all the following conditions are satisfied:

- a) The lift shaft and all its openings are located entirely within a single *firecell* containing the vertical *safe path*.
- b) Passenger access into and from the lift car takes place entirely within the *safe path*.

- c) The *fire hazard category* of any *purpose group* served by the vertical *safe path* and lift is no more than 3.
- d) No other activity occurs within the vertical *safe path*.
- e) The lift machine room is a separate *firecell*, and the openings for lift ropes through the *fire separation* shall be as small as practicable, and any *penetrations*, such as for electrical cables, are *fire stopped*. See Paragraph 6.17 for *fire stopping* and Paragraph 6.10.1 for required *FRR*.

3.13 Refuge Areas

3.13.1 In vertical *safe paths* in tall *buildings*, where required by Table 4.1, refuge areas shall be located at intervals of no greater than every third floor above the lowest *final exit*, except that the topmost refuge area may be 4 floors below the highest occupied floor. In this context the highest occupied floor is as described in the definition of *building height*.

3.13.2 Refuge areas shall provide an additional space within the *safe path* no less than 800 mm wide and 2.0 m² in area, which shall not intrude into the specified width of the *escape route*, or be reduced by any door in, or opening into the *safe path* (see Figure 3.17). A refuge area shall:

- a) Be located at the same level as the horizontal *escape route* it serves, and
- b) Have the same level of *fire protection* (passive and active) as applies to the vertical *safe path* with which it is associated.

COMMENT:

Refuge areas are provided where congestion in the *safe path* may occur. They also allow slow moving *persons* to rest and others to pass.

Figure 3.17: Refuge Areas
Paragraph 3.13.2

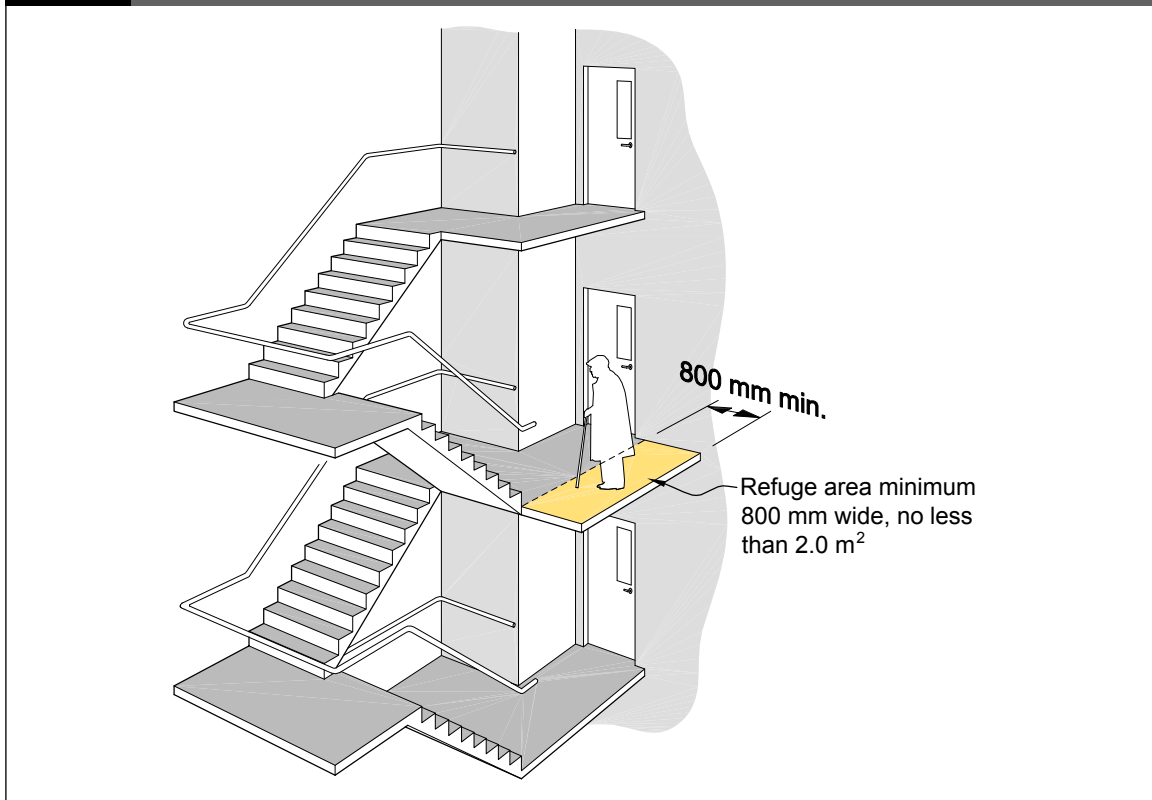

3.14 External escape routes

3.14.1 Where an *escape route* enters a space exposed to the open air (e.g. an open *stairway*, a balcony, across a roof or a ground level path), it shall meet the requirements for a *safe path* between that point and the *final exit*. *Safe path* separation requirements shall be achieved by providing either distance or fire rated *construction* between the *escape route* and adjacent *firecells*, as provided for in Paragraphs 3.14.2 to 3.14.6.

COMMENT:

Balconies with one direction of escape comply with the requirements of a *safe path* if the *external wall* beside the balcony has no *unprotected areas* or the balcony is large enough to allow separation by distance from the *external wall* (see Paragraph 3.14.3). Balconies with two directions of escape from all *firecell* exits are also considered to be *safe paths*, even if the adjacent *external wall* has 100% *unprotected area*.

Separation by distance

3.14.2 Separation by distance shall be achieved by:

- a) Locating the *escape route* no less than the distance required by Paragraph 3.14.3 from *external walls*, or
- b) Locating the *escape route* so that it diverges from *external walls* (see Paragraph 3.14.5 a)), or
- c) Providing alternative directions of escape from the point where the *escape route* passes through an *external wall* and becomes an *external escape route* (see Paragraph 3.14.5 b)).

3.14.3 Where there is only one direction of escape, roofs and *external walls* shall have no *unprotected areas* closer to an external *escape route* than:

- a) 2.0 m if not sprinklered, or
- b) 1.0 m if all *firecells* passed by the external *escape route* are sprinklered.

COMMENT:

This provision is to limit heat radiation exposure to occupants who have only one direction of escape, consequently the limiting distances apply horizontally to both sides of the *escape route*.

3.14.4 Where the distance separating *external walls* or roofs from an external *dead end escape route* is less than permitted by Paragraph 3.14.3, those walls and roofs shall comply with the *FRR* requirements of Paragraphs 7.10 and 7.9.3 to 7.9.5. Glazing complying with Paragraph 5.8.2 shall be permitted.

3.14.5 For an *escape route* which passes through an opening in an *external wall*, the *external wall* need not be *fire rated* where:

- a) The direction of escape to a single *final exit* diverges from the *external wall* at an angle of no less than 45° in plan, or
- b) The directions of escape to alternative *final exits* diverge from each other at an angle of no less than 90° in plan.

COMMENT:

1. It is common for *household units* in *purpose group SR* and *suites* in *purpose group SA*, to have full height glazing adjacent to a balcony which may be the only means of access and egress. This is acceptable only where the balcony provides the occupants with more than one *escape route* from the exit door, enabling them to escape without passing a unit containing a *fire*.
2. The relaxation of *fire resistance rating* requirements does not apply where *fire rated construction* is necessary due to the proximity of a *relevant boundary* (see Paragraph 7.3).

Separation by fire rated construction

3.14.6 Except where the separation distance requirements of Paragraphs 3.14.3 or 3.14.5 can be achieved:

- a) *External walls* and roofs adjacent to external *escape routes* shall comply with the *FRR* requirements of Paragraphs 7.9 and 7.10 and have no *unprotected areas*, except that glazing for *safe paths* complying with Paragraph 5.8 shall be permitted, and
- b) Where the *escape route* is a balcony with a single direction of escape, and the vertical distance between the underside of the balcony and the closest *unprotected area* in the *external wall* below is less than 5.0 m (see Figure 3.18), barriers shall:
 - i) have no openings, and
 - ii) be protected with a *flame barrier*, and

COMMENT:

All barriers must comply with F4/AS1.

- c) Where the vertical separation, between the underside of an external *escape route* and *unprotected areas* in the *external wall* below, is less than 5.0 m:
 - i) the floor of an external *escape route* closer to an *external wall* than the distances required by Paragraph 3.14.3 shall have a *FRR* of no less than that required for the floor of the *firecell* being served, and
 - ii) treads and risers of stairs on external *escape routes* shall either be *constructed* from a material which is a *flame barrier* or shall otherwise be protected on the underside with a *flame barrier*.

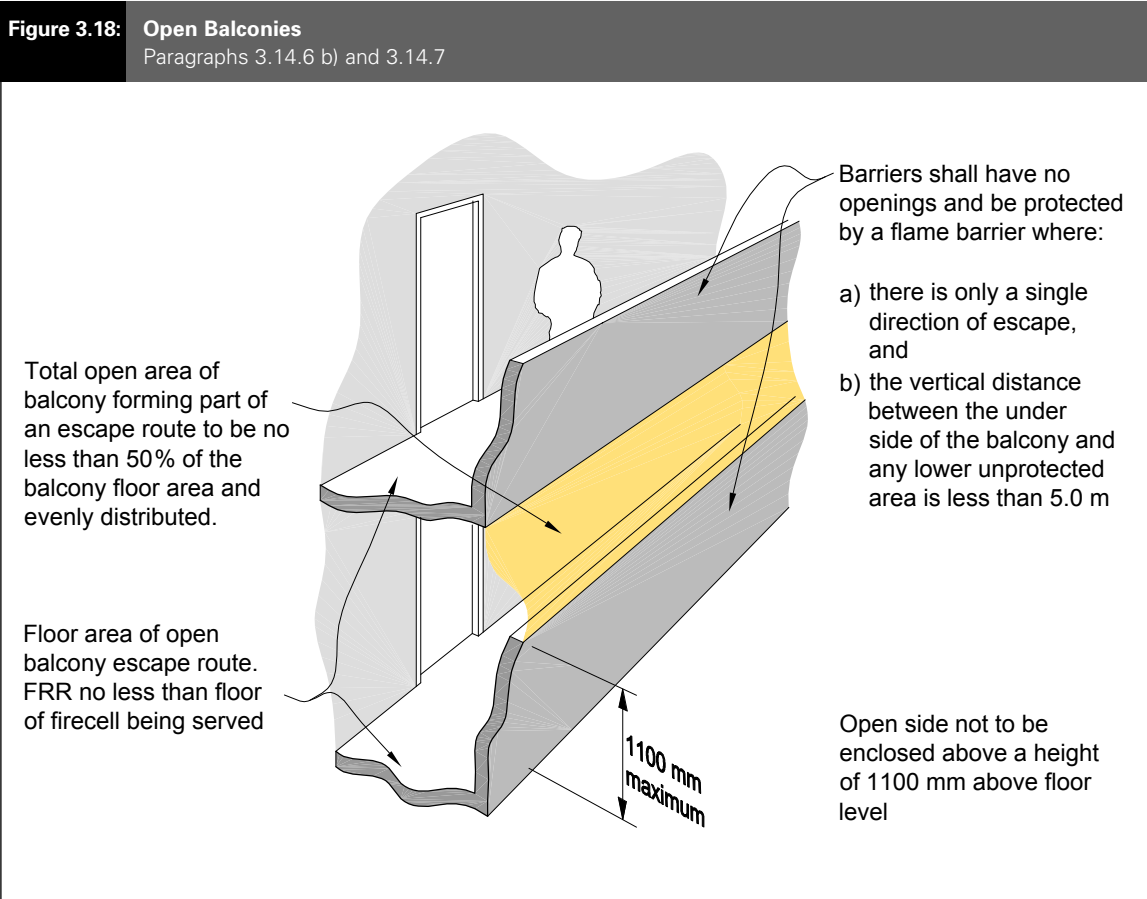

Ventilation openings

3.14.7 The open area of a balcony or bridge shall be no less than 50% of the balcony floor area, and be evenly distributed along the open sides and any approach ramp (see Figure 3.18). Where an *escape route* on a balcony is served by an open *stairway*, similar ventilation shall be provided on the *stairway*. Open sides shall not be enclosed above a height of 1100 mm from the floor, except that a fixed open grille may be used if it provides the required free air space.

Barriers

3.14.8 Changes in *exitway* floor level, other than in the direction of travel shall have barriers that comply with F4/AS1 Paragraph 1.0.

3.15 Single Escape Routes

3.15.1 Single *escape routes* are permitted in *purpose group* SH provided that the 24 m *dead end* length (see Table 3.3) is not exceeded. For other *purpose groups*, single *escape routes* are permitted only where:

- a) The *escape height* is within the limits permitted by Paragraphs 3.15.2 to 3.15.9,
- b) For active *purpose groups*, CS, CM, CO, WL, WM, WH, WF, IA and ID *fire hazard categories* comply with Paragraphs 3.15.3 and 3.15.4, and the *open path* length does not exceed the *dead end* length permitted by Table 3.3,

- c) For sleeping *purpose groups* SA and SR, the requirements of Paragraphs 3.15.5 to 3.15.9 are complied with, and on any floor the distance from the *firecell* exit door to one of the termination points given in Paragraph 3.11.8 does not exceed the *dead end* length permitted by Table 3.3,
- d) The total *occupant load* from all *firecells* on each level served by the *escape route* is no greater than 50, and
- e) The number of preschool children receiving child care, or *people with disabilities* (including those using workshops and dining rooms) on any floor, is not greater than 10.

Basements

3.15.2 A single *escape route* and *final exit* is acceptable from *basements* (see Figure 3.19) where, in addition to the requirements of Paragraph 3.15.1 and the *protected path* requirements of Paragraph 3.7.1:

- a) There are no more than two *basement* floor levels, and
- b) The *fire hazard category* on any floor of the *basement* is no greater than 2.

Figure 3.19: Single Escape Route from Basement Levels
Paragraph 3.15.2

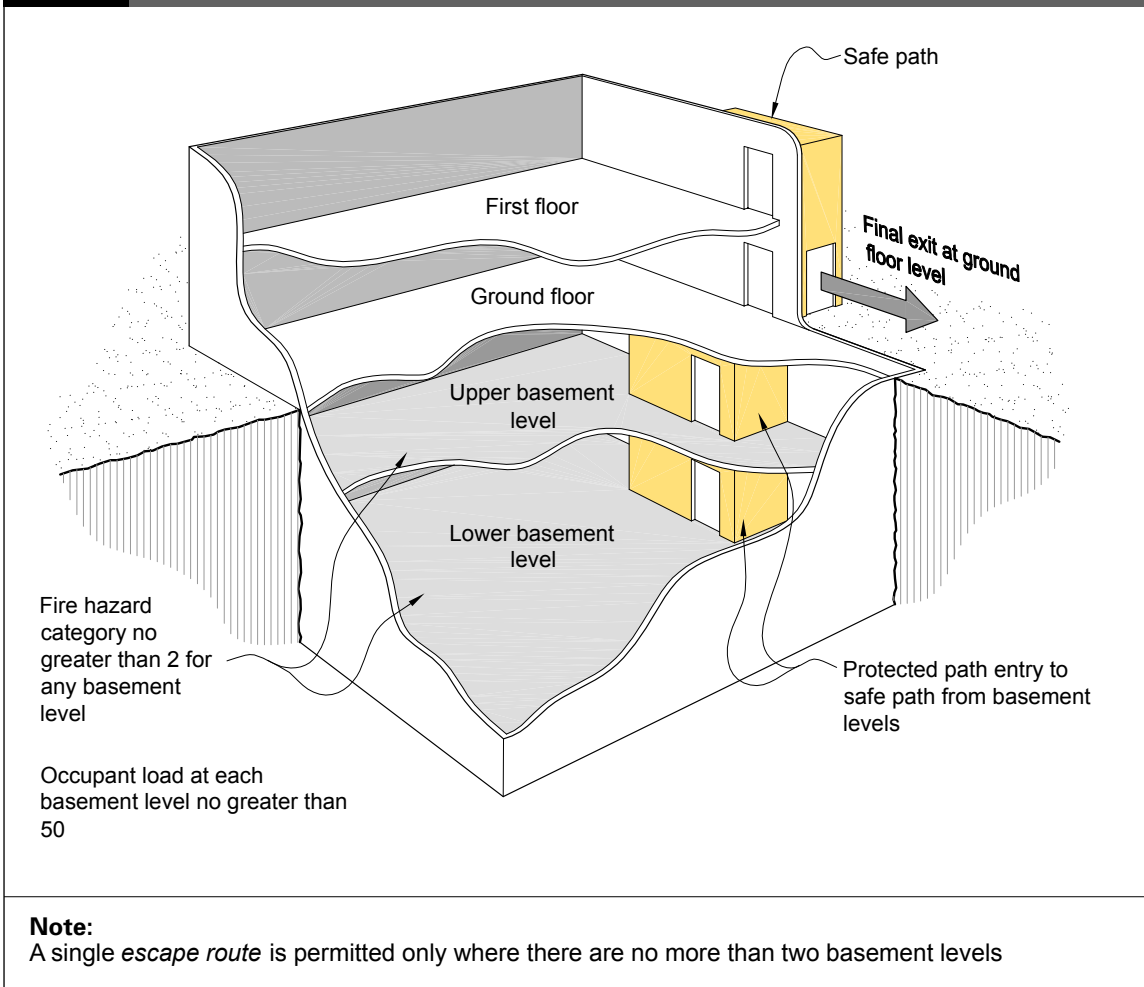

Active purpose groups

3.15.3 Single internal *escape routes* are permitted in *purpose groups* CS, CM, WL, WM, IA and ID where, in addition to the requirements of Paragraph 3.15.1:

- a) The *escape height* is no greater than:
 - i) 4.0 m, (see Figure 3.20 (a)) where the *fire hazard category* on any floor served by the *exitway* is no greater than 3, or
 - ii) 10 m, (see Figure 3.20 (b)) where the *fire hazard category* on any floor served by the *exitway* is no greater than 2 if not sprinklered, or 3 if sprinklered, or
 - iii) 25 m, (see Figure 3.20 (c)) where sprinklered and the *fire hazard category* on any floor served by the *exitway* is no greater than 2, and
- b) In *buildings* with two or more floors, the vertical *safe path* is preceded by a *protected path*, on all floors except the topmost floor.

- c) The length of any *safe path* on a floor does not exceed the maximum *dead end* length permitted by Table 3.3.

Amend 4
Oct 2005

3.15.4 Single external *escape routes* (for balconies, bridges and *external stairways*) complying with Paragraph 3.15.7 are permitted in *purpose groups* CS, CM, WL, WM and IA.

Sleeping purpose groups SR and SA

3.15.5 *Household units* in *purpose group* SR and *suites* in *purpose group* SA may have a single *escape route* from the *firecell* (see Figure 3.21) provided that, in addition to the requirements of Paragraph 3.15.1:

- a) The *escape route* within each *firecell* terminates at a *final exit* or opens onto a *safe path* which complies with the requirements of Paragraphs 3.11.4 to 3.11.11, and
- b) The particular requirements for *stairways*, balconies and split level *exitways*, given in Paragraphs 3.9.14 and 3.15.6 to 3.15.8, are satisfied, and

Figure 3.20: Allowable Escape Height and Fire Hazard Categories for Single Exitways in Purpose Groups CS, CM, WL, WM, IA and ID
Paragraph 3.15.3 a)

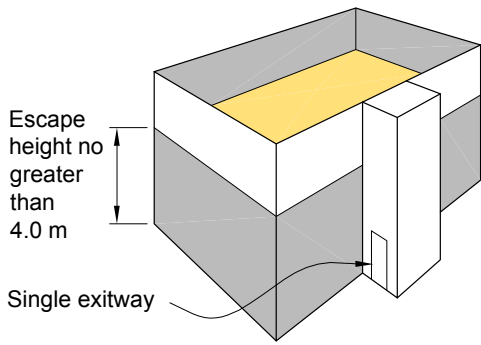

Fire hazard category in any space no greater than 3

(a)

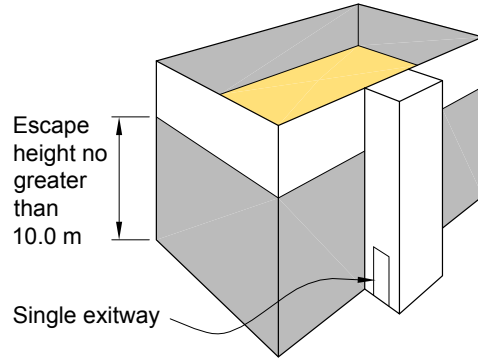

Fire hazard category in any space no greater than 2, or 3 if sprinklered

(b)

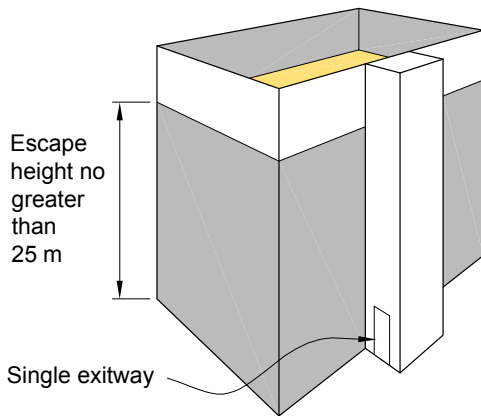

Building sprinklered and fire hazard category in any space no greater than 2

(c)

Notes:

For a single *exitway* to be permitted:

1. The *firecell* served by the *escape route* shall have an *occupant load* of no greater than 50.
2. In *buildings* with two or more floors the vertical *safe path* shall be preceded by a *protected path* at each floor level except for the top floor.
3. Every full floor above the level of the *final exit* shall be a *fire separation* with a *FRR* of no less than 30/30/30.

Figure 3.21: Single Escape Route – Internal Stairs for Purpose Groups SR and SA
Paragraphs 3.15.5 and 3.15.6

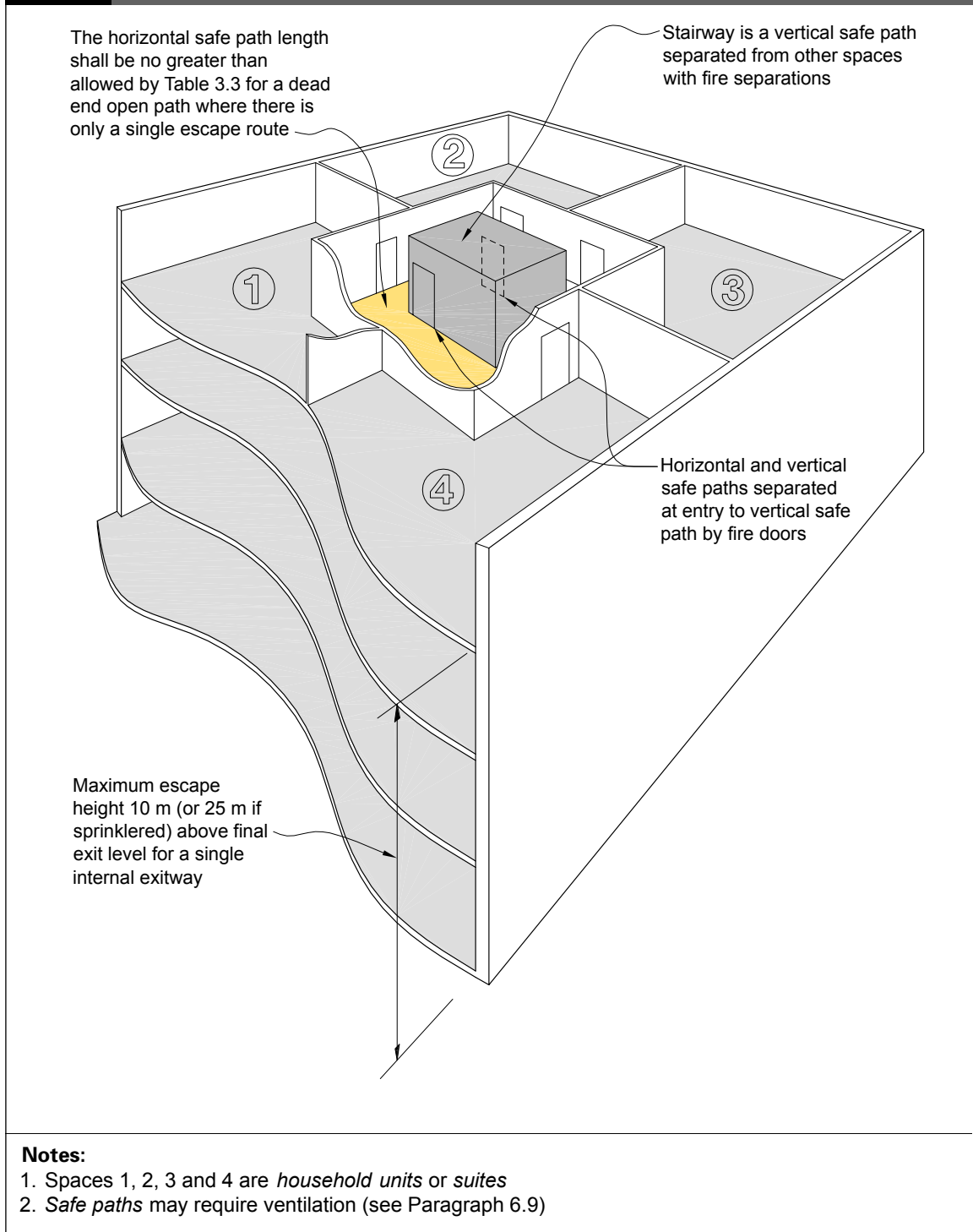

Internal stairways

3.15.6 A single internal *escape route*, being a *safe path stairway*, is permitted from *firecells* in *purpose groups* SR and SA where, in addition to the requirements of Paragraphs 3.15.1 and 3.15.5 (see Figure 3.21), the *escape height* is no greater than 10 m, or 25 m if the *building* is sprinklered. See Paragraph 6.9 for ventilation requirements.

Balconies, bridges and external stairways

3.15.7 Balconies, bridges and external *stairways* (see Figures 3.22 and 3.23) may be part of a single external *escape route* in *purpose groups* SR and SA where:

- a) The *escape height* is no greater than 16 m if not sprinklered, or 25 m if sprinklered, and
- b) The *escape route* on the balcony, bridge and *stairway* meets the requirements of Paragraph 3.14 for protection, *construction* and ventilation, and
- c) The length of any bridge between the *external wall* and *stairway* is no less than 3.0 m.

Split level exitway

3.15.8 Where a *building* is effectively of single storey *construction* but contains individual *household units* at slightly different levels (see Figure 3.24), a single internal *escape route* is permitted provided that:

- a) The *escape route* is a *safe path* leading directly to a *final exit*, and
- b) The difference in floor level between the *final exit* and any exit from a *household unit* is not greater than 2.0 m.

3.15.9 Where the level difference is greater than 2.0 m the relevant provisions for stairs (see Paragraphs 3.15.6 and 3.15.7) shall apply.

Figure 3.22: Single Escape Routes – Direct Access to Balcony and Stairway
Paragraph 3.15.7

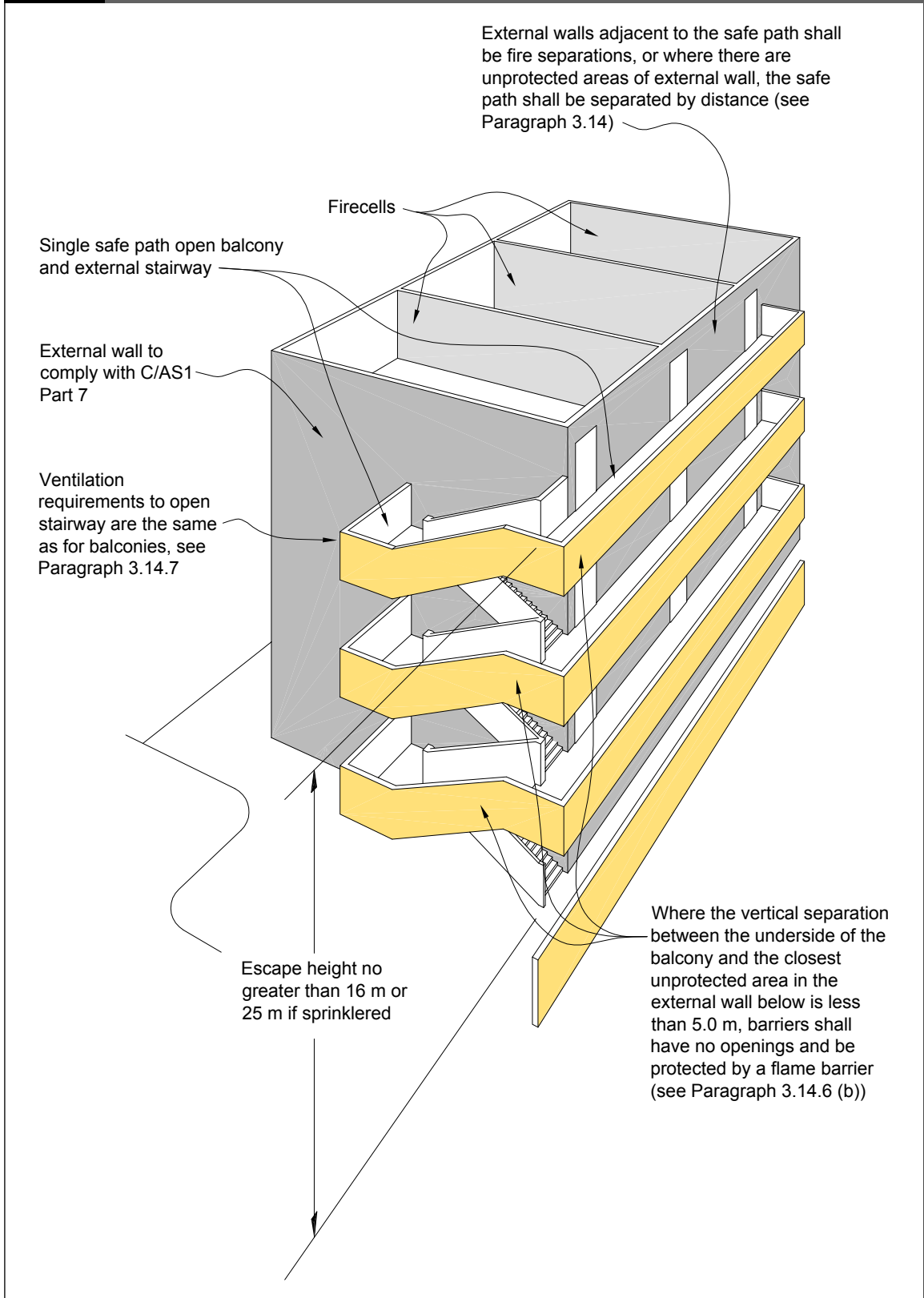

Figure 3.23: Single Escape Routes – Evacuation via Bridge to Separate Stair Tower
Paragraph 3.15.7

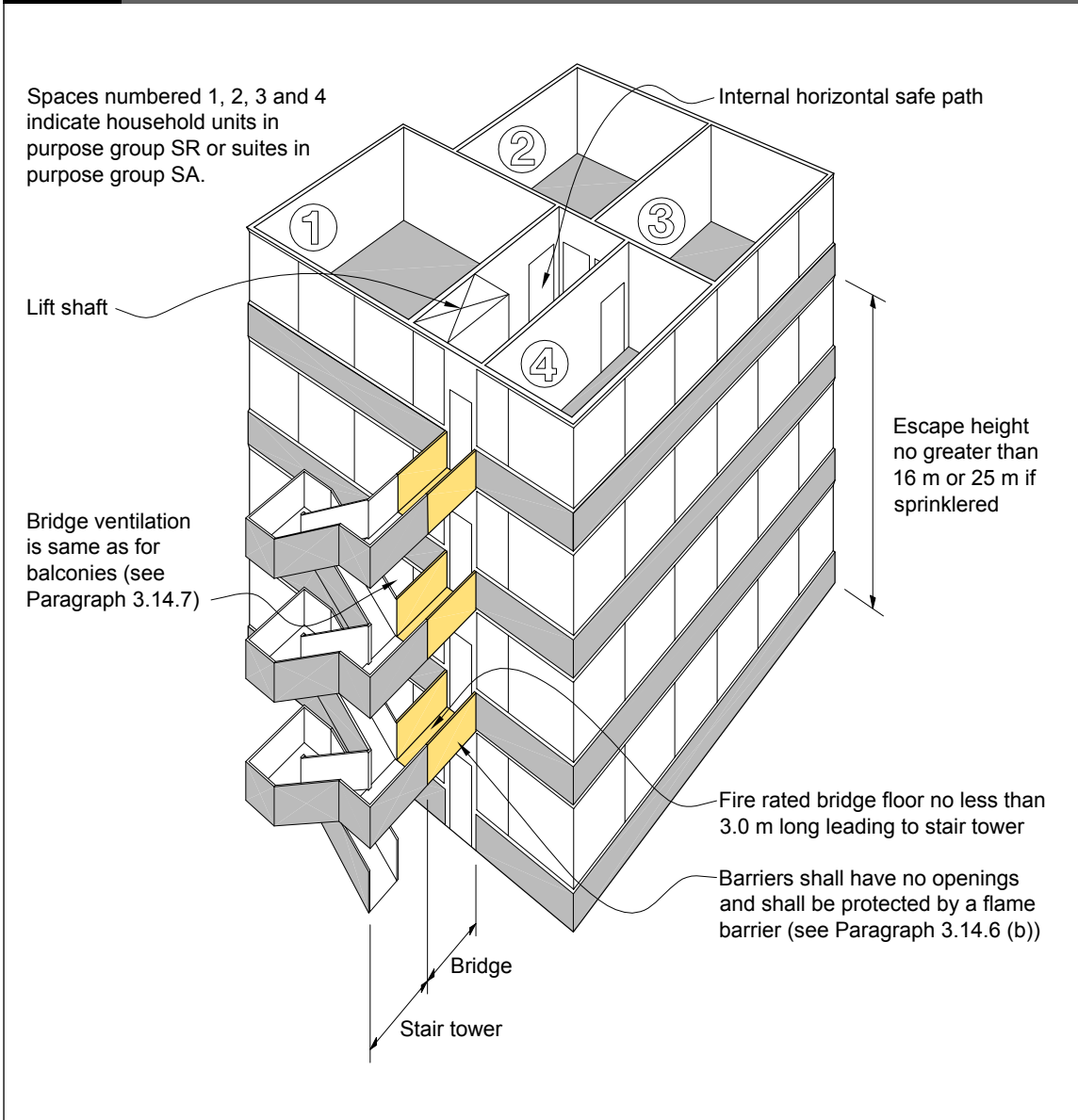
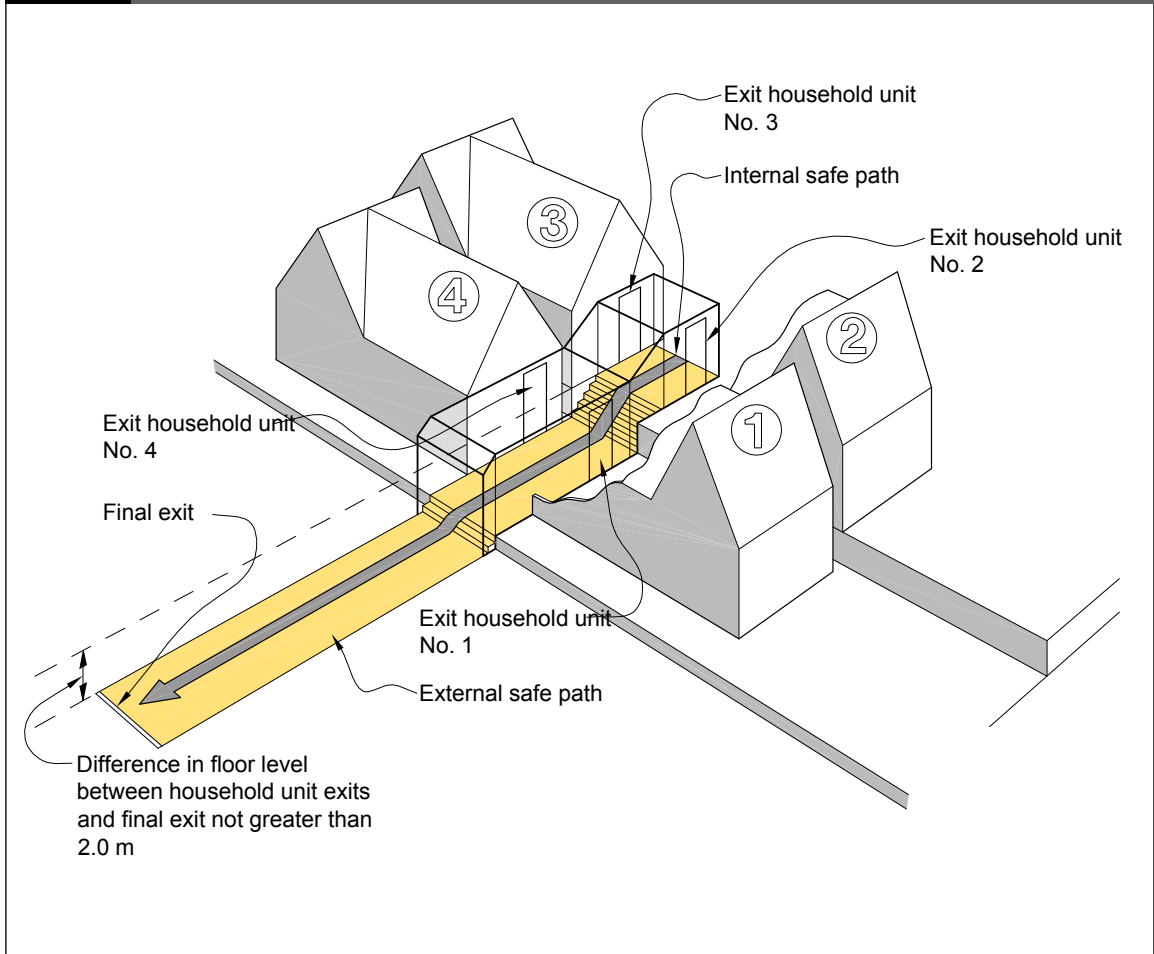

Figure 3.24: Single Escape Routes – Split Level Exitway
Paragraph 3.15.8



3.16 Special Conditions for Crowd and Sleeping Purpose Groups

Purpose group CL

3.16.1 Any *firecell* containing *purpose group CL* shall be served by *safe paths* or *final exits* connecting directly to that *firecell*. The number of *safe paths* shall comply with Table 3.1 for the *occupant load*.

3.16.2 Aisles and walkways between seats shall comply with Paragraphs 3.9.3 to 3.9.9.

Exitways from upper and intermediate floors in purpose group CL

3.16.3 Entrances to vertical *safe paths* shall be preceded by *protected paths* except where:

- a) The *safe path* from an upper floor or *intermediate floor* serves only that floor, or
- b) The *firecell* is sprinklered, or
- c) The *occupant load* of the *firecell* is less than 150, or

- d) *Fire safety precaution* Type 8 is installed and an approved staged evacuation scheme is operable.

COMMENT:

1. An upper floor is any floor above *final exit* level. See Paragraphs 3.4.3 and 3.4.5 for required *protected path* floor area.
2. With a staged evacuation scheme the *firecell* of fire origin is the first to be evacuated.

Final exit separation

3.16.4 *Final exits* which open onto the same *safe place*, shall be spaced no closer than 5.0 m centre to centre. This applies to both internal and external *exitways*.

COMMENT:

This provision allows quick dispersal and reduces the risk of a crowd blocking a *final exit*.

Open air auditoriums, purpose group CO

3.16.5 Open tiered seating decks shall:

- a) Have the number of *exitways* required by Table 3.1 for the *occupant load*,
- b) Comply with Paragraphs 3.9.3 to 3.9.9 for aisles, and walkways between seats (Table 3.4 permits seat numbers to be doubled in *purpose group CO*),
- c) Have *exitways* spaced at no more than:
 - i) 60 m apart where the space below the seating deck is required to be *fire separated* (see Paragraph 6.5), or
 - ii) 20 m apart where the space below requires no *fire separation*, and
- d) Be served by *escape routes* completely open to the air where the seating deck is not a *fire separation*.

3.16.6 Where the seating deck is required to be a *fire separation*, an *escape route* may pass through the deck and the space below, provided that part of the *escape route* is a *safe path* with a *FRR* based on no less than the *F rating* required for the lower space.

3.16.7 A grandstand in which the roof configuration, or *building elements* such as screens or partial glazing, restrict the escape of smoke and hot gases, shall, even if having a large open area, be classified in *purpose group CL* and not *CO*.

Purpose groups SC, SD, SA and SR

3.16.8 At least half the *safe paths* serving *purpose groups SC* and *SD* shall terminate in a *safe place* without being combined with an *escape route* from any other *purpose group*.

3.16.9 *Safe paths* serving *purpose groups SA* and *SR* may also serve other *purpose groups* where:

- a) A single *escape route* complying with Paragraph 3.15 is permitted, or
- b) Alternative *escape routes* which are *safe paths* are provided.

These requirements shall also apply to all *firecells* on lower floors using the same *escape routes*.

COMMENT:

Any *building* with sleeping *purpose groups* on upper floors is required by Paragraph 4.5.11 to have appropriate *fire alarm systems* on all lower floors.

3.17 Doors Subdividing Escape Routes**Door closers and latching**

3.17.1 Except as permitted by Paragraph 3.17.7 (revolving doors, automatic doors and access control systems), doors into or within *exitways* shall satisfy all the following requirements by being:

- a) Hinged or pivoted on one vertical edge only.
- b) Self-closing, and the self-closing device shall be:
 - i) active at all times, or
 - ii) activated by releasing a *hold-open device* in response to operation of a smoke detector (see Paragraph 3.17.10), or

iii) a self-closer that is activated by operation of a smoke detector but allows the door to swing freely at other times. The smoke detector requirements shall be the same as for a *hold-open device* (see Paragraph 3.17.10).

c) Fitted with panic bolts complying with Paragraph 3.17.14 and situated in accordance with Paragraph 3.17.16 or simple fastenings that can be readily operated from the side approached by people making an escape complying with Paragraph 3.17.15.

Amend 7
Nov 2008

d) Not fitted with any locking devices unless they comply with Paragraph 3.17.2.

e) Have door handles which satisfy the requirements for use by *people with disabilities*.

f) *Constructed* to ensure that forces required to open the doors do not exceed 67 N to release the latch (where fitted), 133 N to set the door in motion, and 67 N to open the door to the minimum required width.

COMMENT:

D1/AS1 Paragraph 7.0 gives appropriate guidelines with respect to handle height and the need for single-handed lever action mechanism.

Locking devices

3.17.2 Where the *building* is occupied, locking devices shall:

a) Be clearly visible, located where such a device would be normally expected, designed to be easily operated without a key or other security device, and allow the door to open in the normal manner,

COMMENT:

Card access and keypad locks are examples of unacceptable security devices.

b) Not prevent or override the direct operation of panic bolts fitted to any door, and

c) If of an electromechanical type, in the event of a power failure or door malfunction, either:

i) automatically switch to the unlocked (fail-safe) condition, or

ii) be readily opened by an alternative method satisfying the requirements of Paragraph 3.17.2 a).

COMMENT:

1. There should be a place in a *building* management plan procedure, which has been approved by the *building consent authority*, to ensure that all *escape route* doors are unlocked when anybody is lawfully in the *building*.

Amend 7
Nov 2008

2. Where people are held under restraint, alternative proposals must be consistent with the requirements of the "Fire Safety and Evacuation of Buildings Regulations 2006".

Amend 9
Oct 2011

3. Where the method of operation of a locking device is not obvious, signage complying with NZBC Clause F8.3.1 should be provided to indicate the location and release procedure for the locking device. For example, pressing a button on a wall beside the door.

4. NZBC Clause C2.3.3 (b) requires *escape routes* to be "free of obstruction in the direction of escape". This does not prevent *owners*, for security purposes, locking *escape route* doors when the *building* is unoccupied.

Direction of opening

3.17.3 Doors on *escape routes* shall be hung to open in the direction of escape, and where escape may be in either direction doors shall swing both ways. These requirements need not apply where the number of occupants using the door is no greater than:

a) 20 in an *open path*, or

b) 10 into and within an *exitway* including *final exit* doors.

Amend 7
Nov 2008

3.17.4 Doors used for the passage of beds in *purpose groups* SC and SD, shall be capable of swinging in both directions, and in the case of *purpose group* SC the doors shall be of sufficient width to allow the passage of a bed and essential patient life support equipment.

Degree and width of opening

3.17.5 Doors on *escape routes* (see Figure 3.25 shall satisfy all the following requirements:

- a) In *open paths* provide an unobstructed opening width of no less than 760 mm, and when multi-leaf, have no single leaf less than 500 mm wide. The minimum door opening width may be reduced to 600 mm where it is not required to be an *accessible route*.
- b) Within *exitways* (including entry and *final exit* doors), reduce the minimum *exitway* width (required by Paragraph 3.3.2), by

no more than the 125 mm allowed under Paragraph 3.3.6 e).

- c) Open no less than 90°.
- d) Open onto a floor area which:
 - i) extends for a distance of no less than the arc of the door swing, and
 - ii) is at the same level on both sides of the door for the full width of the *escape route*.

COMMENT:

A 20 mm threshold weather stop is acceptable on external doors (see D1/AS1).

- e) When opened, not cause the door swing to obstruct the minimum required width of any *escape route*. For example, doors which open onto a corridor used as an *escape route*, shall not obstruct the minimum required width of that *escape route*.

Figure 3.25: Degree and Width of Openings
Paragraphs 3.3.6 e) and 3.17.5

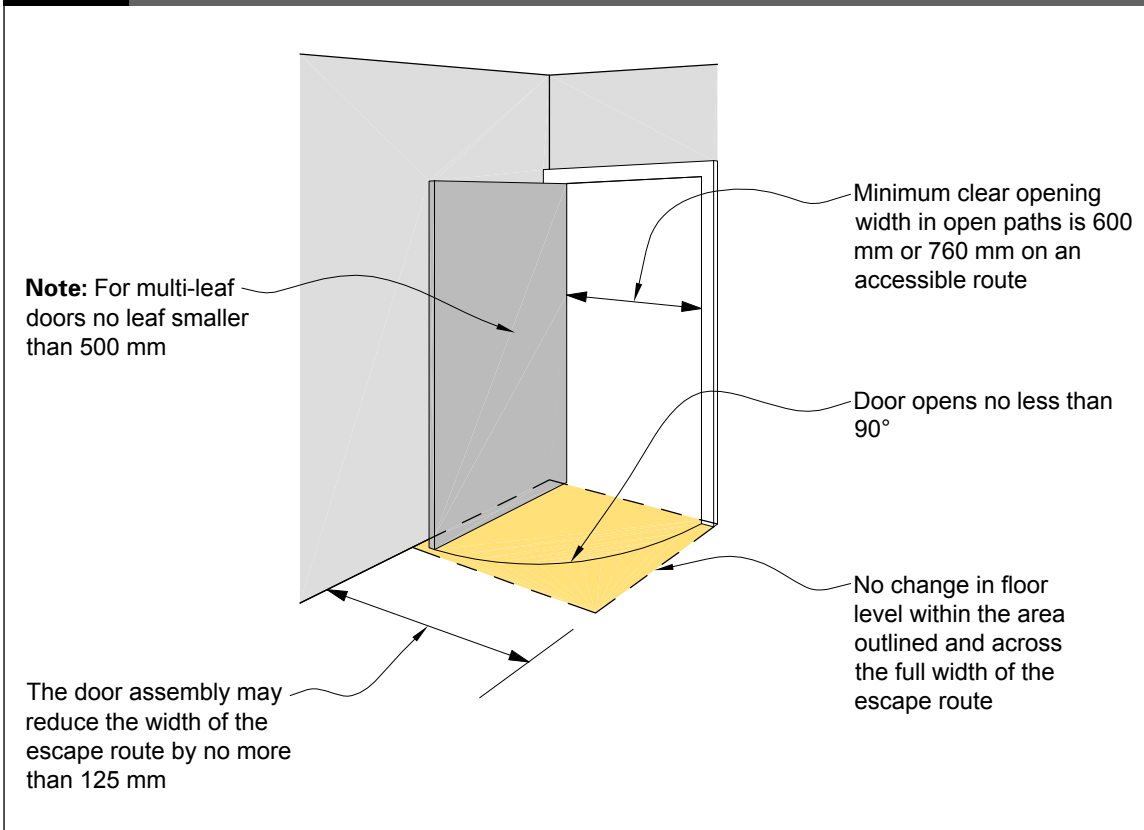

Vision panels

3.17.6 Vision panels shall be provided on doors which:

- a) Are hung to swing both ways,
- b) Lead into or are within *exitways*, except when the number of *persons* using the door is not greater than 10, or
- c) Subdivide corridors used as *escape routes*.

COMMENT:

See Paragraph 5.8.10 for vision panel glazing requirements.

Revolving doors, automatic doors and access control systems

3.17.7 Revolving doors (see Figure 3.26 (a)), automatic doors (of all types) and access control systems shall:

- a) Not be allowed across an *escape route* at any point leading into or within an *exitway*, but
- b) Be allowed in an *open path* or at a *final exit*, provided that in the event of a power failure or malfunction, the doors or access control systems continue to provide a safe means of escape without reducing the required width by:
 - i) automatically opening and remaining open, or
 - ii) being readily pushed to the outward open position by the *building* occupants in an emergency (refer to Figure 3.26 (b))

COMMENT:

Access control systems may be in the form of turnstiles or entrance gates, in both horizontal and vertical planes, as found in shopping centres, entertainment venues and similar occupancies.

3.17.8 Paragraph 3.17.7 b) need not apply if alternative swing doors of the required width are provided immediately adjacent to the revolving or sliding doors.

Hold-open devices

3.17.9 *Hold-open devices* shall be fitted to *fire doors* or *smoke control doors* required:

- a) Between *open paths* and *exitways* in *purpose group* CL where the *occupant load* is greater than 1,000,
- b) Between horizontal and vertical *safe paths* in *purpose groups* SC, SD, SA and SR,
- c) For subdividing long corridors in all *purpose groups* (see Paragraph 6.13.1), and
- d) In *fire separations* where an *escape route* passes into an adjacent *firecell* in *purpose groups* SC, SD, SA and SR (see Paragraph 3.9.12).

COMMENT:

1. Detector-actuated *hold-open devices* are used where it is not practical to assume *fire doors* and *smoke control doors* will remain closed, because of the type or volume of occupant traffic using the doors. The devices should eliminate the unsafe practice of wedging or otherwise keeping self-closing doors open.
2. In many situations, for the amenity of occupants, it is useful to provide a clearly labelled push button release adjacent to doors with *hold-open devices*.

3.17.10 *Fire* detectors for releasing *hold-open devices* shall be smoke detectors which are:

- a) Integral with the *hold-open device* and complying with Paragraph C8.1.6 of Appendix C, or
- b) Located on the wall above or ceiling adjacent to the *doorset* on both sides of the *doorset*, or
- c) Part of an automatic smoke detection system on both sides of the *doorset*.

Delayed action unlocking devices

3.17.11 Delayed action unlocking devices may be installed only where:

- a) The *firecell* is protected by *fire safety precaution* Type 4 (automatic *fire* alarm activated by smoke detectors) or Type 7, and

Figure 3.26: Revolving and Automatic Sliding Doors
Paragraph 3.17.7

Revolving doors are permitted across an open path or final exit provided they are constructed to fail safely in an emergency.
Revolving doors are not allowed across an escape route leading to or within an exitway

Alternatively outward opening doors shall be provided immediately adjacent to the revolving doors

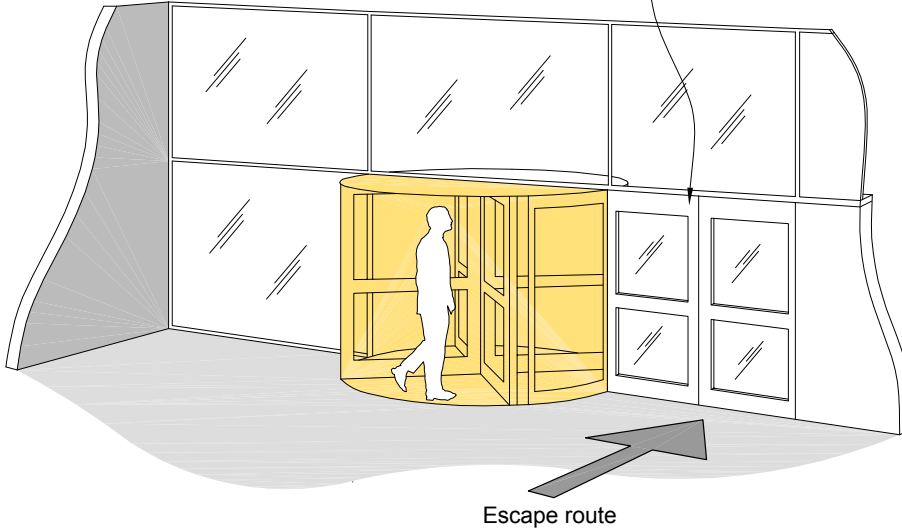

(a)

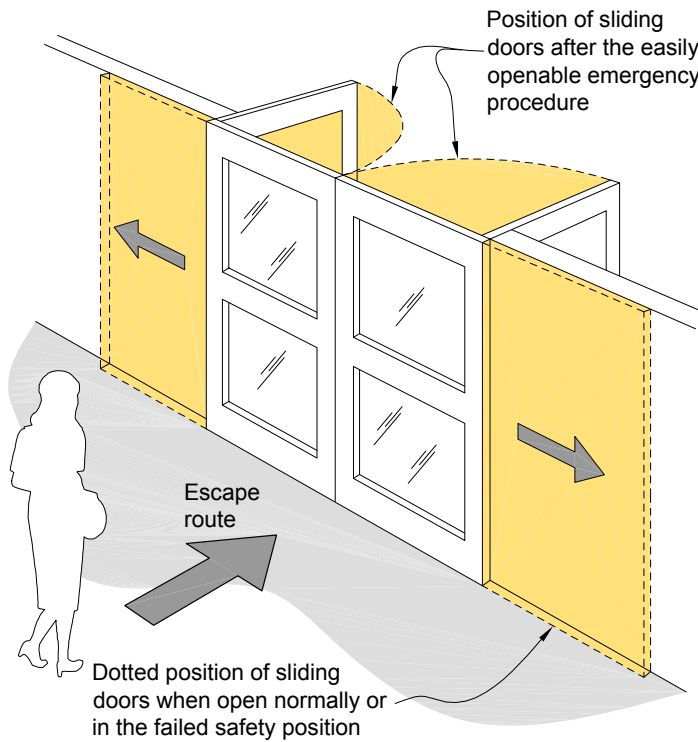

(b)

- b) Fire alarm activation instantly overrides any delay, and
- c) The delay in operation does not exceed 15 seconds, and
- d) Signage warning of the delay in operation and complying with NZBC Clause F8.3.1 is provided.

COMMENT:

A delayed action unlocking device is a security mechanism which allows a door to be unlocked without the use of a key, but does not release the door under non-emergency conditions until a time delay has elapsed. The time delay allows the person intending to use the door to be checked for security reasons.

Smoke control doors

3.17.12 Smoke control doors complying with Paragraphs 6.19.1 to 6.19.8 shall be provided:

- a) At smoke control divisions in vertical safe paths as required by Paragraph 6.9.11 (see Figure 6.1).
- b) Where a corridor or an escape route passes through a smoke separation (see Figure 3.27 and for long corridors Figure 6.5).
- c) Between an open path and a protected path (see Figures 3.28 and 3.30).

Figure 3.27: Smoke Control Doors
Paragraph 3.17.12 b)

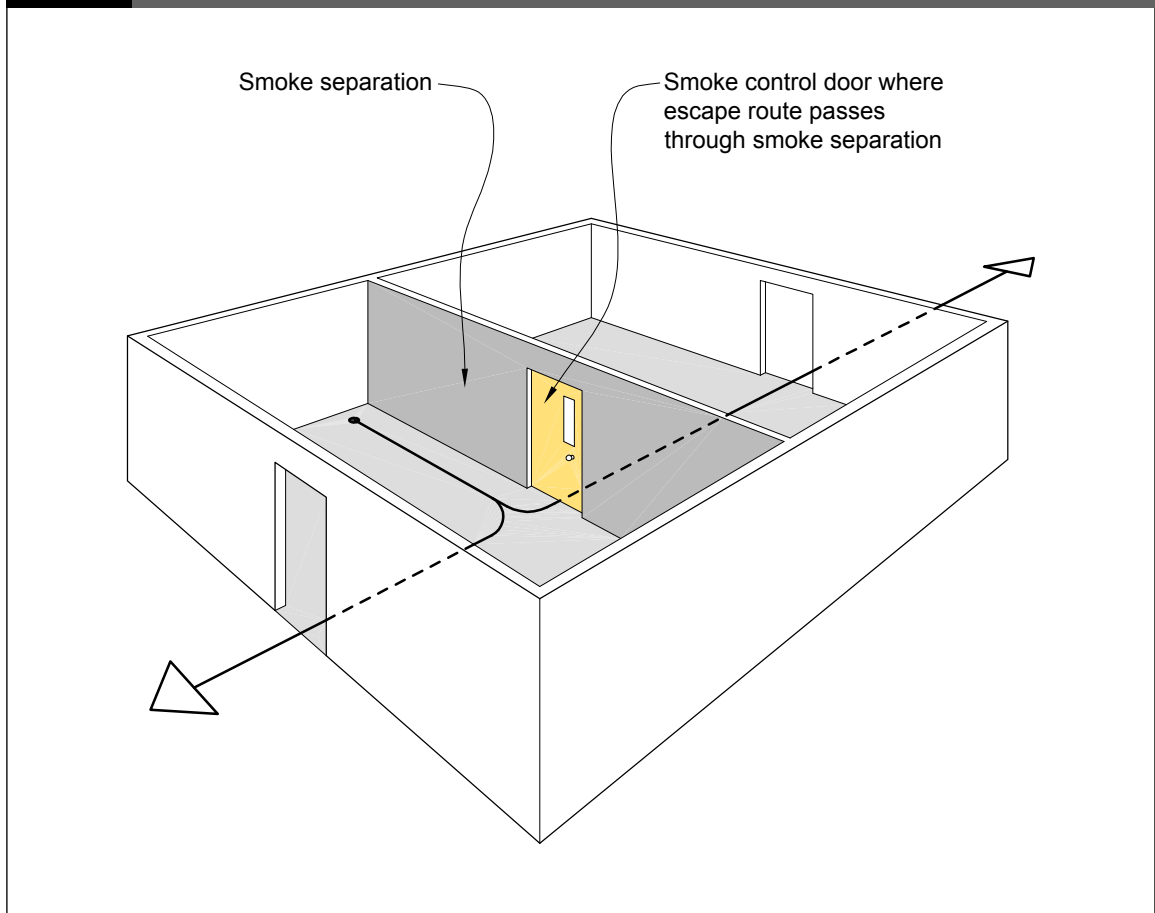
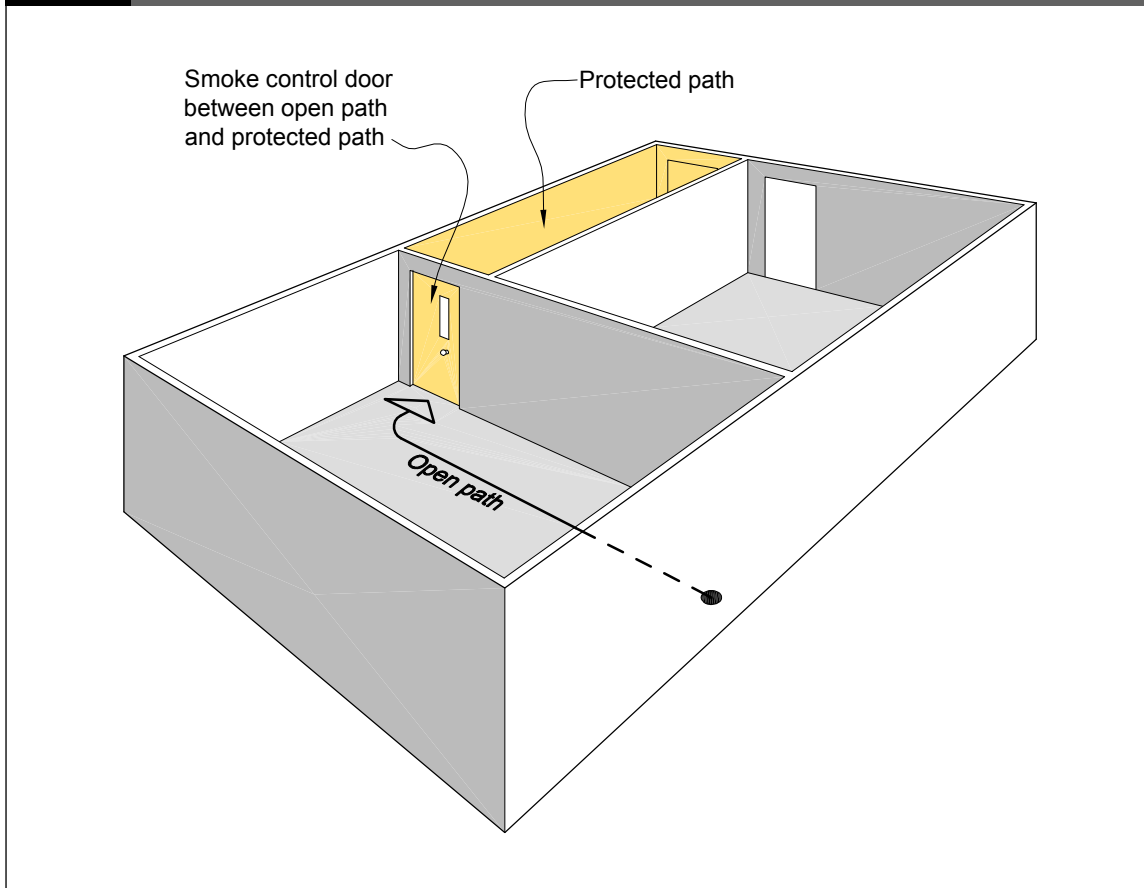

Figure 3.28: Smoke Control Doors on Protected Paths
Paragraph 3.17.12 c)



Fire doors

3.17.13 Fire doors complying with Paragraphs 6.19.1 and 6.19.8, and Paragraph C8.1 of Appendix C, shall be provided:

- Between an *open path* and a *safe path* (see Figure 3.29).
- Between a *protected path* and a *safe path* (see Figure 3.30).
- Where the *escape route* passes through a *fire separation* (see Figure 3.16) or into an adjoining *building* (see Figure 3.11).
- Where the *escape route* passes through a *fire separation* which isolates the *safe path* from levels below the *final exit*. (See Figure 3.31 and Paragraph 6.9.3.)
- In *fire separations* between vertical and horizontal portions of internal *safe paths*.

COMMENT:

Doors at *final exits* are not required to have any *fire* protection. *Fire doors* in *exitways* are required to protect occupants from the effects of *fire* during evacuation. *Fire doors* at the head of stairs to *basements* isolate the *basement* section of the vertical *safe path*.

Figure 3.29: Fire Doors
Paragraph 3.17.13 a)

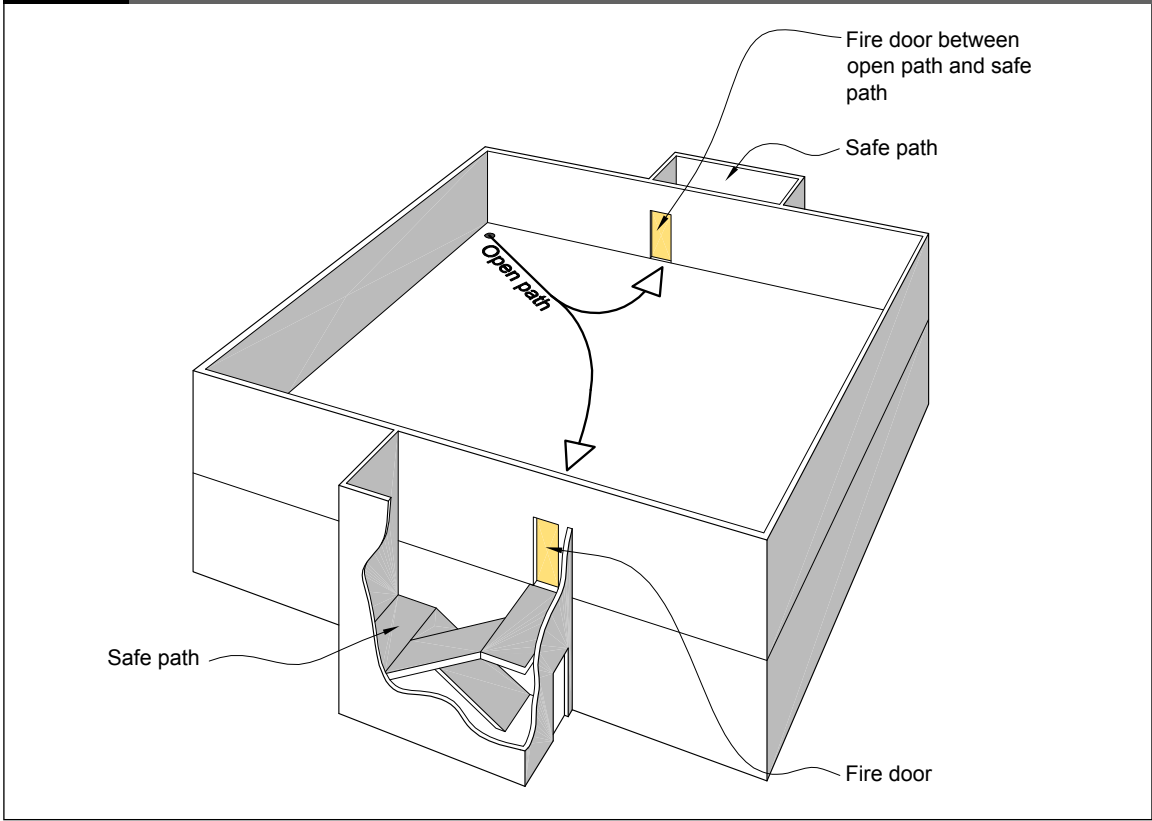

Figure 3.30: Fire Doors and Smoke Control Doors
Paragraphs 3.17.12 c) and 3.17.13 b)

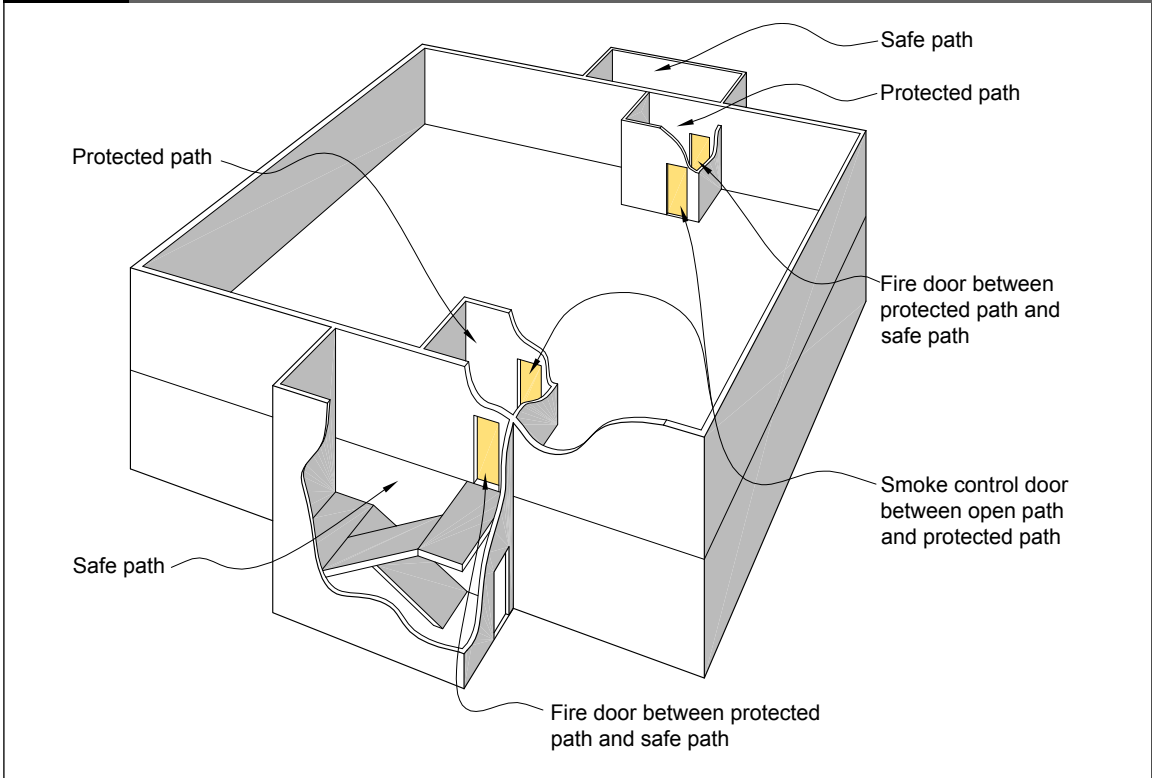
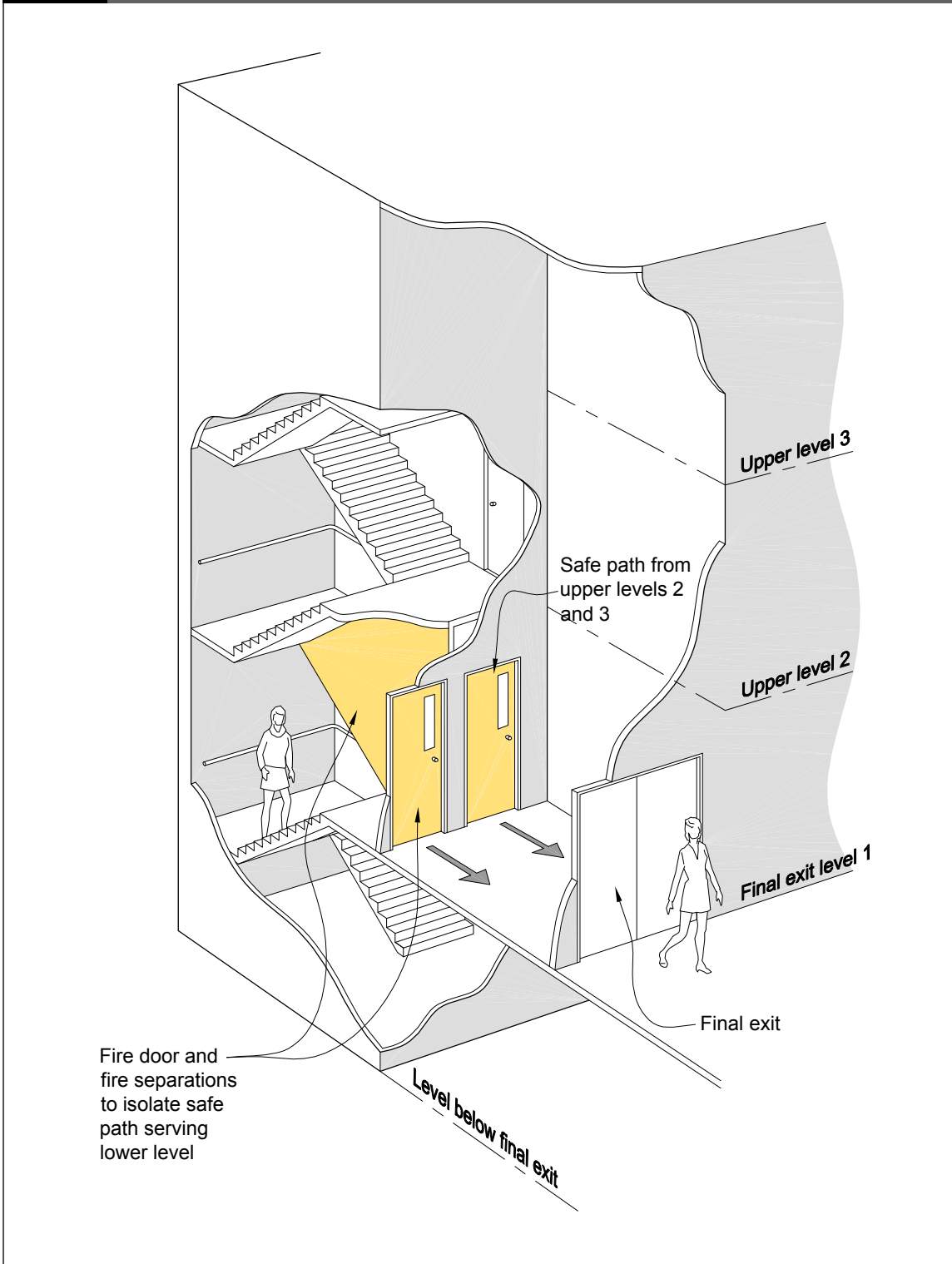

Figure 3.31: Fire Doors to Separate Floors Above and Below Final Exit Level
Paragraph 3.17.13 d)



Panic bolts

3.17.14 Panic bolts are locking devices which shall meet the following requirements:

- a) The actuating portion shall consist of a horizontal bar or panel which shall extend across no less than half the width of the door leaf, and be located between 800 mm and 1200 mm above the floor,
- b) When a horizontal force not exceeding 67 N is applied to the bar or panel, the door lock shall release allowing the door to swing open freely.

Simple Fastenings

3.17.15 In general, doors on *escape routes* (whether or not the doors are *fire doors*) should only be fitted with simple fastenings that can be easily operated from the side approached by people making an escape. This generally excludes the use of keyed locks and bolt fastenings.

Panic Fastenings

3.17.16 Panic fastenings shall be fitted on doors on the means of escape including *exitways* and *final exits* in *purpose group CM* serving more than 500 occupants or *purpose group CL*.

For *purpose groups* other than CM serving more than 500 occupants and *purpose group CL*, other types of simple fastenings shall be fitted on doors on the means of escape including *exitways* and *final exits* which are required to be secured against entry when a *building* or part of a *building* is occupied.

COMMENT:

Doors that exit the *building* may do so directly to a *safe place* (e.g. *final exit door*) or to an area, such as an alleyway or bridge, that gives access to a *safe place*.

Amend 7
Nov 2008

Amend 7
Nov 2008

Figure 3.32: Windows Used for Escape
Paragraphs 3.18.1 and 3.18.3

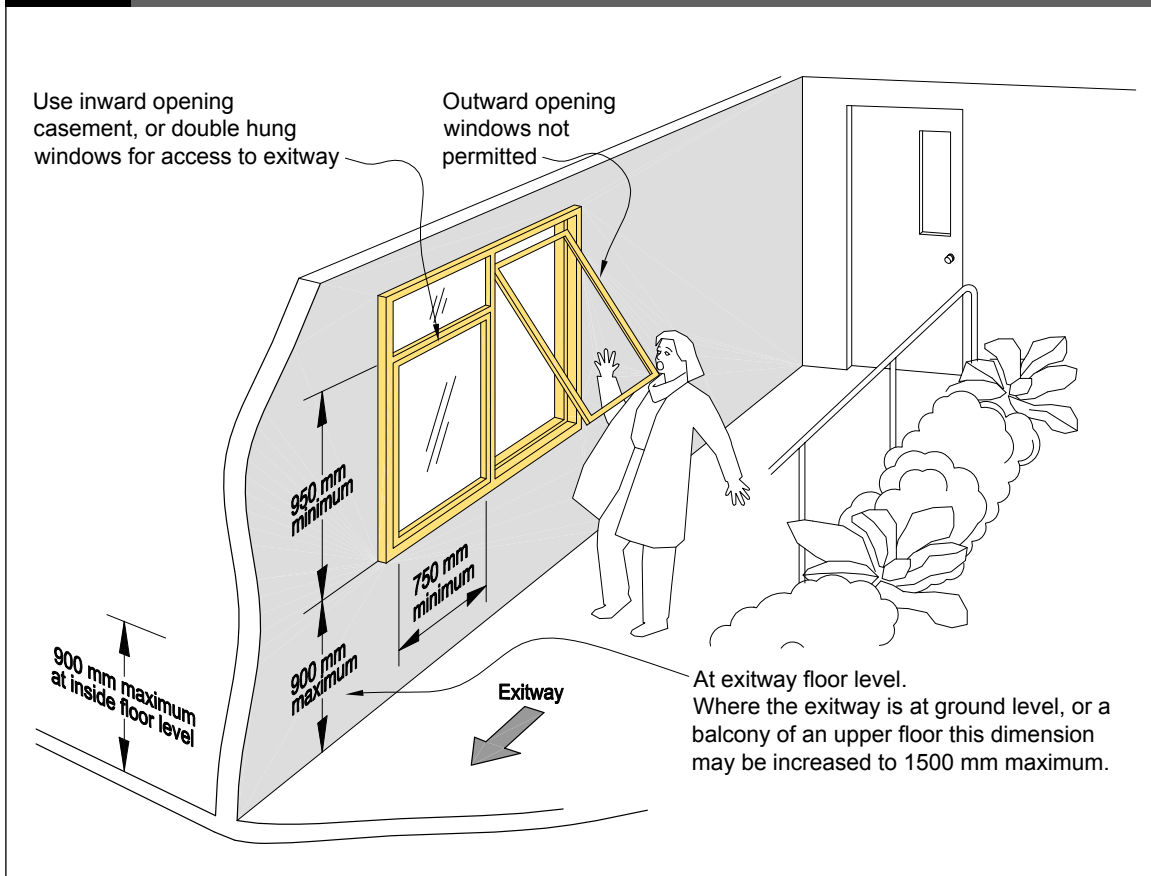

3.18 Windows Used for Escape

Application

3.18.1 A window may provide an alternative *final exit* or direct access to one external alternative *exitway* in *buildings* (see Figure 3.32), where all occupants have normal mobility, *escape height* is no greater than 4.0 m, and *purpose groups* consist only of CS (excluding *early childhood centres*), SA, SR or WL.

3.18.2 Windows shall not be used as access to an *exitway* where only a single *exitway* exists.

COMMENT:

While windows in these situations are not part of a formally recognised means of escape, it is accepted that they may be used by occupants in emergencies.

Obstruction to be avoided

3.18.3 Windows permitted to be used for access to any *exitway*, when opened, are not to obstruct any *escape route* (see Figure 3.32).

Size

3.18.4 Windows used for access to any *exitway* shall be *constructed* with a minimum clear opening of 950 mm high by 750 mm wide. The opening sash shall be capable of remaining in the fully opened position without assistance from occupants.

Sill height

3.18.5 The bottom of the clear opening shall be no more than 900 mm above floor level of the *escape route* on each side of the opening where it discharges into an *exitway*. A built-up platform of a length no less than the clear opening width may be used to provide access to each side of the window. This is not required externally where the distance between bottom of the clear opening and the finished ground level adjacent to the *building*, or a balcony of an upper floor, is no greater than 1500 mm.

Latching

3.18.6 Windows used for access to any *exitway* shall be capable of being easily and quickly opened with one hand, and any locking devices shall comply with Paragraph 3.17.2 a) to avoid escape being hindered.

Escape capacity

3.18.7 Windows used for escape shall be credited with the capacity to evacuate 10 occupants for every 750 mm clear opening width. If the sill height is no greater than 600 mm, the number may be doubled to 20 occupants.

3.19 Lighting

Artificial lighting

3.19.1 *Exitways* shall be provided with artificial lighting as required by NZBC G8.

Lighting for emergency

3.19.2 *Buildings* shall be provided with lighting for emergency as required by NZBC F6, and Table 4.1.

3.20 Signs

3.20.1 All *purpose groups* except within *household units* in *purpose groups* SR and SH shall have signs complying with NZBC F8, in *escape routes*, and on *fire doors* and *smoke control doors*.

Amend 4
Oct 2005

Occupant load on the floor being considered (Note 1)		Minimum number of escape routes
Purpose groups SC, SD		
Up to	50 beds	2
Over	50	2 plus (Note 2)
Purpose groups SA, SR		
Up to	100 beds	2
Over	100	2 plus (Note 3)
Purpose groups CS, CL, CO, CM, WL, WM, WF, WH, IA, ID		
Up to	500	2 (Note 4)
Up to	1000	3
Up to	2000	4
Up to	4000	5
Up to	7000	6
Up to	16,000	8
Over	16,000	8 plus (Note 5)

Notes:

- Guidance on determining *occupant load* is given in Part 2. Special conditions applying to crowd and sleeping *purpose groups* are contained in Paragraph 3.16.
- Plus 1 for every 100 beds, or part thereof over 50.
- Plus 1 for every 100 beds, or part thereof over 100.
- Special cases allowing single *escape routes* are given in Paragraph 3.15.
- Plus 1 for every 5000, or part thereof increase in *occupant load*, above 16,000.

Table 3.2: Width of Escape Routes
Paragraphs 3.3.2, 3.3.2 h), j) and k), 3.3.6 b), 3.9.12 e)

	Purpose groups		
	CS, CL, CM, SA, SR, WL, WM, WH, WF, IA, ID	SC, SD	CO (Note 9)
Minimum width of individual escape routes (mm)			
Horizontal travel	850 (Notes 1, 2, 3, 5)	1200	1000
Vertical travel (Notes 7 and 8)	1000 (Note 2)	1500 (Note 4)	1200 (Note 5)
Required total combined width of all escape routes (Note 6) (mm per person)			
Horizontal travel	7	8	2
Vertical travel (Notes 7 and 8)	9	10	3
Column 1	2	3	4

Notes:

- The width of an *escape route* within an *exitway*, excluding the entry door (see Paragraph 3.3.2 a)), shall be no less than 1000 mm.
- Where there is no requirement to provide for *people with disabilities*, and the *occupant load* is less than 50, widths of *escape routes* when an *open path*, may be reduced to 700 mm for horizontal travel, and 850 mm for vertical travel.
- For gangways between fixed storage in other than public areas, width may be reduced to 530 mm.
- These widths apply only to *escape routes* from sleeping areas, but the width from column 2 may be used for *escape routes* serving only:
 - Occupants of non-sleeping areas, or
 - Sleeping areas where the number of beds is less than 10 and the occupants are active and can be directed by staff, or
 - Occupants who are active, ambulant and require no assistance to escape.
- For areas of fixed or loose seating:
 - Escape routes* shall comply with the requirements of Paragraphs 3.9.3 and 3.9.4 for aisles and width between rows.
 - From the termination of an aisle the minimum *escape route* width shall be the greater of the aisle width or the width required by Paragraph 3.3.2.
- The width calculated on *occupant load* determines any extra width required, but in no case shall the width be less than the minimum for individual *escape routes*.
- For limitations on width of the *escape route* in *stairways* and where the *escape height* exceeds 34 m, see Paragraphs 3.3.3 and 3.3.4.
- Ramps with a slope of not more than 1:8 may be regarded as horizontal travel.
- The widths given in column 4 apply only to *escape routes* wholly in the open air. Any enclosed part of the *escape route* shall be the width determined for CL using column 2 and that width shall not be reduced even if the *escape route* subsequently passes to the open air.

Table 3.3: Lengths of Open Paths and Protected Paths
Paragraphs 1.3.4, 3.4.1 a), 3.4.2 b), d) and e), 3.4.4, 3.4.6, 3.4.8, 3.5.1, 3.5.2, 3.5.3, 3.5.6, 3.8.1, 3.9.7, 3.11.7, 3.15.1 b) and c), 3.15.5 c), 6.8.2 and Figures 3.7, 3.15 and 3.21

Type of path	Purpose groups				
	SC, SD (Note 4)	WF	CS, CL, CM, SA	WL, WM, WH, SR, SH	CO, IA, ID
	Maximum length (m)				
Dead end open path	18	12	18	24	36
Total open path (Note 5)	45	30	45	60	90
Protected path	45	30	45	60	90
Column 1	2	3	4	5	6

Notes:

- Where the *occupant load* exceeds 50, there shall be two or more *escape routes* from any space.
- In accordance with Paragraphs 3.5 and 3.11.7 *open path* lengths and horizontal *safe path* lengths (but not protected paths), may be increased by:

	SA, SR, SH	CS, CL, CM, WL, WM, WH, IA, ID
where heat detectors are installed	10%	20%
where sprinklers are installed	50%	100%
where smoke detectors Types 4, 5 or 7 are installed	50%	100%
- Paragraph 3.5.6 gives the circumstances where permitted increases, in the lengths of *dead end* and total *open path* may be combined.
- Because *purpose groups* SC and SD are required by Table 4.1 always to have sprinklers and smoke detectors, no increases in accordance with Paragraph 3.5 are permitted for those *purpose groups*.
- Allowed only if there is more than one *escape route*, but shall include any initial *dead end* length.

Table 3.4: Walkways in Fixed Seating
Paragraphs 3.3.6 c), 3.9.3 b) and c), 3.16.5 b) and Figures 3.13, 3.14

Minimum walkway width (mm) (Note 1)	Maximum number of seats in any row (Note 2)	
	Where one aisle only	Where aisles both sides
300	7	14
340	9	16
380	9	18
420	10	20
460	11	22
500	12	24

Notes:

- The walkway width is measured between the foremost part of the seat and the backmost part of the seat in front of it.
- For *purpose group* CO, the number of seats in a row may be doubled.

Acceptable Solution C/AS1

Part 4: Requirements for Firecells

4.1 General Principles

4.1.1 To meet the performance requirements of NZBC C3 Spread of Fire, this acceptable solution provides a number of safeguards to control *fire* spread, the most important being:

- a) Internally, by:
 - i) dividing a floor, in certain *purpose groups*, into *firecells* to facilitate rescue and protect *household units* and *other property*,
 - ii) requiring floors (except in small *buildings* with low *occupant load*) to be *fire separations*,
 - iii) providing *fire separations* between *firecells* and *safe paths*,
 - iv) providing sprinklers within *firecells* or *buildings*, and
- b) Externally, by:
 - i) *constructing external walls* to avoid vertical *fire* spread outside the *building*, and
 - ii) *constructing external walls* to limit horizontal *fire* spread by thermal radiation.

COMMENT:

1. Priority is given to life safety, and less emphasis is applied to property protection than in NZS 1900: Chapter 5 (now superseded), but to which existing *buildings* were designed.
2. Precautions for protecting *other property* apply only to parts of a *building* which if collapse occurred would cause damage across a *relevant boundary*, or damage to an adjacent *household unit*.

4.1.2 To prevent *fire* spread or structural collapse, *building elements* are *constructed* with a *fire resistance rating (FRR)* appropriate to the perceived risk. For some situations the *FRR* has been prescribed, for others it is derived from either the *firecell rating (F rating)* or the *structural fire endurance rating (S rating)*.

The subject of *fire* ratings is covered in Part 5.

COMMENT:

The *F rating* is aimed at ensuring life safety and allowing *fire* fighters to undertake rescue operations and protect *other property*. The *S rating* is aimed at preventing collapse and *fire* spread which would damage *other property*, and ensuring that areas of *external wall* not permitted to be *unprotected area* contain an internal *fire* for the *S rating* time.

4.2 Provision of Firecells

Number of firecells

4.2.1 A *building* may comprise one or more *firecells* depending on the *fire hazard*. *Firecells* are required to contain a *fire* for sufficient time to allow safe evacuation, and to prevent *fire* spreading to other *firecells* or *adjacent buildings*.

4.2.2 *Firecells* may also be divided into *smokecells* to restrict the spread of smoke and hot gases during escape.

Firecell floor area limits

4.2.3 Except as permitted by Paragraph 4.2.4, the floor area of an unsprinklered *firecell* to which an *S rating* applies, shall not exceed the maximum *firecell* floor area given in the following table.

Fire hazard category (from Table 2.1)	Maximum firecell floor area (m ²)
1	5000
2	2500
3	1500
4	Specific fire engineering design required

COMMENT:

Firecell floor area limits assist *fire*-fighting operations, and are set to limit total *fire load* to approximately 2,000,000 MJ in unsprinklered *firecells*.

4.2.4 In an unsprinklered single floor *building* where the *building elements* supporting the roof are not *fire* rated, the *firecell* floor area may be unlimited provided that no less than 15% of the roof area (distributed evenly throughout the *firecell*) is designed for effective *fire* venting.

COMMENT:

Roof venting systems such as drop-out panels, louvre vents or ridge venting shall be designed and proven for the purpose of facilitating firefighting operations. The Australasian Fire and Emergency Services Authorities Council's Fire Brigade Intervention Model (www.afac.com.au/awsv2/learning/fbim.htm) provides guidance on performance criteria for firefighters. Less than 15% roof area for venting may be acceptable if total system performance can be demonstrated.

4.2.5 Where a *firecell* is sprinklered, except when *purpose groups* require subdivision or other area limitations are imposed by this Compliance Document, the *firecell* floor area may be unlimited.

Fire safety precautions for firecells

4.2.6 *Fire safety precautions (FSPs)* within *firecells* shall ensure that:

- a) Occupants, in the event of *fire*, have reasonable warning and protection while making their escape to a *safe place*,

- b) The spread of *fire* is restricted, and
- c) Fire Service personnel have sufficient time to undertake rescue operations.

Assessing FSP requirements

4.2.7 In this acceptable solution:

- a) *Fire safety precautions* are determined for individual *firecells* and vary according to the *purpose group* contained and the *escape height*.
- b) *Fire safety precautions* increase with increases in *occupant load* and *escape height*.
- c) Where a *firecell* contains more than one *purpose group*, the *fire safety precautions* to be applied are those of the primary *purpose group*, as described in Paragraphs 2.2.2 to 2.2.5.

4.3 Table 4.1

Limitations of table

4.3.1 Table 4.1 lists the *fire safety precautions* for individual *firecells* in a *building* but, on its own, does not provide all the information necessary to satisfy the *fire safety precautions* for the whole *building*. Users of the table must be familiar with the definitions and the contents of all Parts of this acceptable solution.

4.3.2 *Fire resistance ratings* for floors are determined from the required *F rating* for the *firecell* below, except where specific requirements apply to floors separating *other property* or *basement* levels, and to *intermediate floors* (see Paragraphs 5.3.2 d), 6.14.3 and 6.14.4).

Purpose groups SH, CO, IE, IA, ID

4.3.3 These *purpose groups* are not included in Table 4.1. Specific requirements for *purpose groups* SH, CO, IE, IA and ID are given in Paragraphs 1.3.4, 6.5, 6.9, 6.10 and 6.11 respectively.

Amend 7
Nov 2008

Amend 7
Nov 2008

Amend 5
Oct 2005

4.4 Using Table 4.1

4.4.1 Table 4.1 is applied by following steps 1 to 9.

Step 1 Determine for each *firecell*:

- a) The *purpose group* contained.
- b) The primary *purpose group* (see Paragraph 2.2.2) where more than one.
- c) The *occupant load* (includes all *purpose groups* in the *firecell*).
- d) Whether it contains *intermediate floors*.
- e) The *escape height* from the *firecell*.

Step 2 Choose the appropriate page of Table 4.1 for the *purpose group* and *occupant load* of the *firecell* being considered. Note that Tables 4.1/1 to Table 4.1/4 are for active *purpose groups* each applying to a different range of *occupant loads*. Table 4.1/5 for sleeping *purpose groups* is a single page with permitted *occupant load* variations being provided in the notes to the table.

Step 3 Select the horizontal panel for the appropriate *purpose group* as identified in the left hand column.

Step 4 From the top row of the table select the correct column for the *firecell escape height*.

Step 5 From that column note the required *F rating* and numbered *fire safety precautions* for the *firecell*.

Step 6 Using the key at the front of Table 4.1, identify the nature of the required *fire safety precautions* by reading the description beside each Type number. Note also any special applications identified by alphabetical suffixes in the table.

Step 7 Repeat the process for all *firecells* in the *building*.

Step 8 Determine the *fire safety precautions* for the whole *building* by applying the relevant provisions of Paragraph 4.5.

Step 9 Check whether the notes below Table 4.1 apply to the *firecell* being considered.

COMMENT:

In many cases the analysis of *fire safety precautions* will produce different requirements for different *firecells* in the *building*. It is for the *owner* to decide the most practical arrangement that satisfies the requirements both for individual *purpose groups* and the *building* as a whole.

4.5 Determining FSPs for Whole Building

More than one purpose group on a floor

4.5.1 For multiple *purpose groups* on one floor level, the necessary *fire safety precautions* depend on whether the *purpose groups* occupy the same *firecell* (see Paragraph 4.5.5), or the floor is divided by *fire separations* into different *firecells*.

4.5.2 Where different *purpose groups* are each located in separate *firecells*, each *purpose group* shall adopt the requirements of Table 4.1 which apply to that group. This means a single floor level can have different *fire safety precautions* in each *firecell*.

4.5.3 Where, according to Table 4.1, any *firecell* on a floor level requires a Type 2 alarm, all other *firecells* on that floor shall have no less than a Type 2 alarm.

4.5.4 Where by Table 4.1, any *firecell* on a floor requires a Type 3, 4, 5, 6 or 7 alarm, all other *firecells* on that floor level shall have no less than a Type 3 alarm.

Amend 7
Nov 2008

4.5.5 Where *fire separations* are not needed between different *purpose groups* on the same floor level, the *FSPs* adopted for the whole floor level shall be those of the primary *purpose group*, except when a concession is permitted by satisfying Paragraph 5.6.7.

Amend 5
Oct 2005

4.5.6 The alarm systems required by Paragraphs 4.5.3 and 4.5.4 shall be interconnected to alert all occupants of that floor level in the event of *fire* (see Paragraphs 4.5.8 to 4.5.18 for other floor levels in the *building*).

F ratings

4.5.7 Where, on one floor in the *building*, *firecells* have different *F ratings* in accordance with Table 4.1, the greatest *firecell F rating* shall be applied to common spaces and shared *escape routes* for that floor level.

COMMENT:

Within each *firecell* the *FRR* for both *primary* and *secondary elements* is based on the *F rating* for that *firecell* (see Paragraph 5.3.1).

Amend 5
Oct 2005

Other floors in a building

4.5.8 In a *building* with two or more floor levels:

- a) Selection of appropriate *fire safety precautions* shall take account of the specific requirements of each *purpose group* and its location within the *building*, and
- b) No *firecell*, other than the top floor *firecell* (see Paragraph 4.5.14), shall have a *firecell rating* of less than column 2 from Table 4.1 for that *purpose group* and *FHC*.

Amend 4
Oct 2005

4.5.9 Where by Table 4.1 any *firecell* in a *building* requires a Type 2 alarm, all other *firecells* on all floor levels in that *building* shall have no less than a Type 2 alarm.

4.5.10 Where by Table 4.1 any *firecell* in a *building* requires a Type 3, Type 4, Type 5, Type 6 or Type 7 alarm:

- a) All other *firecells* on all floors in that *building* shall have no less than a Type 3 alarm, except that

Amend 7
Nov 2008

- b) Where any *firecell* having an *escape height* greater than 25 m requires a Type 6 or 7 alarm, all lower floor levels in the *building* shall have no less than a Type 6 alarm. In such situations the Type 6 alarm shall replace any Type 2, 3 or 4 alarm otherwise required for lower *firecells*.

4.5.11 Where any upper floor contains a sleeping *purpose group*, all floors below shall have an appropriate alarm system which shall activate alerting devices in all sleeping areas within the *building*. For SC or SD all lower floors shall, regardless of *purpose group* contained, have sprinklers (Type 6 or 7). For SA *purpose group* all lower floors shall, regardless of the *purpose group* contained, have heat or smoke detectors or sprinklers (Types 3, 4 or 6). For SR *purpose group* where any lower floor contains a *purpose group* other than SR, those *firecells* on a lower floor with a *purpose group* other than SR shall have heat or smoke detectors or sprinklers (Types 3, 4 or 6).

Amend 7
Nov 2008

4.5.12 The alarm systems required in a *building* shall be interconnected to alert all *building* occupants in the event of *fire*.

COMMENT:

Safe evacuation of a *building* in the event of *fire*, particularly for sleeping *purpose groups*, depends largely on providing early warning to the occupants. For the purpose of early warning:

- smoke detectors provide the fastest response
- heat detectors and sprinklers are next
- manual call point systems are considered to have the slowest response, being dependent on human activation.

Same purpose group on different floors

4.5.13 Where *firecells* containing the same *purpose group* occur at different levels in the same *building*, the *FSPs* required by Table 4.1 for the *firecell* (containing that *purpose group*) having the greatest *escape height*, shall be applied to all *firecells* in that *purpose group*.

Top floor firecells

4.5.14 A top floor *firecell* may have a *F rating* of F0, but all other *FSPs* required by Table 4.1 for that *purpose group* and *escape height* shall be applied.

Basements

4.5.15 Apply the *fire safety precautions* for *basement firecells* based on the *occupant load* and the greatest *escape height*.

COMMENT:

Because the *fire safety precautions* in *firecells* are increased with increases in distance from the *final exit* (normally related to *escape height*), the precautions for *basement firecells* increase with *basement* depth and the requirements of Table 4.1 shall be applied downward as opposed to upward for *buildings* above ground. Refer to Paragraph 6.14.4 for *FRR* of floors separating *basement firecells* from *firecells* above ground level.

Intermediate floors

4.5.16 *Intermediate floors* and the supporting elements shall have a *FRR* in accordance with Paragraph 6.14.3. All other *FSPs* required for the *firecell* (at the *firecell escape height*) shall apply to the *intermediate floor*.

COMMENT:

Where the *firecell* requires two or more *final exits* and they are located on different levels, the *escape height* of the *firecell* is measured as the greatest vertical *travel distance* for a *person* escaping, from any floor in the *firecell* to the level of the most distant of the required *final exits* (see definition of *escape height*, comment 2).

4.5.17 Except for limited area *intermediate floors* meeting the provisions of Paragraphs 6.21.5 and 6.21.6, all *firecells* containing *intermediate floors* shall have a smoke control system.

4.5.18 Smoke control requirements for *limited area atrium firecells* are given in Paragraph 6.22. For all other *firecells* containing *intermediate floors*, except where Paragraph 4.5.17 applies, smoke control shall be by specific *fire* engineering design.

Early Childhood Centres

4.5.19 *Firecells* containing an *early childhood centre* and not otherwise protected by a Type 4 or Type 7 alarm, shall include a smoke detector in any sleeping area and in any *escape route* serving that area. The smoke detection and alarm system shall comply with NZS 4512.

COMMENT:

The smoke detectors are supplementary to Type 2 or Type 3 alarm required under Table 4.1 to provide earlier warning and *adequate* escape.

4.5.20 Where the *escape height* of a *firecell* containing an *early childhood centre* is greater than or equal to 4 m, all *firecells* in the building shall be sprinklered.

4.5.21 Where spaces used by children are located on an *intermediate floor* within an *early childhood centre* no less than a Type 4 alarm is required throughout the *firecell*.

Specific requirements

4.5.22 Before finalising *FSPs*, check any specific requirements for particular circumstances and *purpose groups* in other Parts of this acceptable solution.

COMMENT:

There may be significant cost advantages in exceeding Table 4.1 *FSP* requirements to achieve other benefits, and specific requirements may apply to less common circumstances not covered in Table 4.1. Examples are on page 100.

Amend 4
Oct 2005

Amend 4
Oct 2005

Amend 4
Oct 2005

PART 4: REQUIREMENTS FOR FIRECELLS

Part 3

- 3.3.2 c) Reduced *escape route* width if *firecell* sprinklered.
- 3.5.2 Increased *open path* lengths if *firecell* sprinklered.
- 3.9.12 f) Lower floors must be sprinklered where escape is via an adjacent *firecell* for sleeping *purpose groups*.
- 3.9.13 d) Smoke control required for *intermediate floor*.
- 3.12.2 b) Sprinklers or smoke detectors required in *exitways* containing activities.
- 3.14.3 Sprinklers reduce separation distance for external *escape routes*.

Part 4

- 4.2.5 Unlimited *firecell* floor area with sprinklers.
- 4.5.10 b) Sprinklers required on lower floors where *escape height* greater than 25 m.
- 4.5.11 Heat detectors, smoke detectors or sprinklers required on all floors below SC, SD, SA or SR *purpose groups*.

Part 5

- 5.6.6 Reduced *FRR* requirement for sprinklers where sprinklers not required by Table 4.1.
- 5.6.10 Sprinklers required in *FHC 4 firecells*.

Part 6

- 6.3.2 Sprinkler and venting requirements for *theatre* stages.
- 6.16.6 Sprinklers required in laundry and solid waste chutes.
- 6.16.8 Sprinkler requirements in *protected shafts*.
- 6.19.9 Sprinkler requirements for proscenium walls.
- 6.20.5 Concessions on *surface finish* requirements if *firecell* is sprinklered.
- 6.22.7 to 6.22.14 Smoke control for *limited area atriums*.
- 6.22.14 Smoke detector requirements in mechanical smoke extraction systems.

Amend 5
Oct 2005 |

Amend 5
Oct 2005

Amend 5
Oct 2005

Table 4.1: Fire Safety Precautions	
Key to table references	
Part 3	Paragraphs 3.1.5, 3.13.1 and 3.19.2
Part 4	Paragraphs 4.3, 4.3.1, 4.3.3, 4.4.1, 4.5.2, 4.5.3, 4.5.4, 4.5.7, 4.5.8, 4.5.9, 4.5.10, 4.5.13, 4.5.14, 4.5.15, 4.5.19
Part 5	Paragraphs 5.5.1, 5.6.6, 5.6.8, 5.9.4 (c)
Part 6	Paragraphs 6.2.1, 6.4.1, 6.7.1, 6.8.1, 6.8.5, 6.8.6, 6.10.1, 6.11.1, 6.15.1, 6.19.9, 6.21.2, 6.23.1 (d), 6.23.2, 6.23.3
Part 8	Paragraphs 8.2.1, 8.2.2, 8.2.3
Appendix A	Paragraphs A1.1.1 and A1.1.2

Amend 4
Oct 2005

Amend 4
Oct 2005

Amend 7
Nov 2008

Fire safety precautions		Special applications
Type	Description	
1	Domestic smoke alarm system.	a Not required where:
2	Manual fire alarm system.	i) the <i>escape routes</i> serve an <i>occupant load</i> of no more than 50 in <i>purpose groups</i> CS (excluding <i>early childhood centres</i>), CM, WL, WM, WH and WF, or
3	Automatic fire alarm system with heat detectors and manual call points.	ii) the <i>escape routes</i> are for <i>purpose group</i> SA and serve no more than 10 beds, (or 20 beds for trampers huts, see Paragraph 6.20.6), or
4	Automatic fire alarm system with smoke detectors and manual call points.	iii) exit doors from <i>purpose group</i> SA and SR <i>firecells</i> open directly onto a <i>safe place</i> or an external <i>safe path</i> (see Paragraph 3.14).
5	Automatic fire alarm system with modified smoke/heat detection and manual call points.	b Where only a single <i>escape route</i> is available, no less than a Type 4 alarm is required. See Paragraph 3.15.3 for situations where sprinklers are required.
6	Automatic fire sprinkler system with manual call points.	c Required where Fire Service hose run distance, from the Fire Service vehicular access (see Paragraph 8.1.1) to any point on any floor, is greater than 75 m.
7	Automatic fire sprinkler system with smoke detectors and manual call points.	
8	Voice communication system.	
9	Smoke control in air handling system.	
10	Natural smoke venting.	
11	Mechanical smoke extract.	
12	No Type 12 currently specified.	
13	Pressurisation of safe paths.	
14	Fire hose reels.	
15	Fire Service lift control.	e The smoke detection element is Type 5 within <i>firecells</i> containing sleeping accommodation. (See Appendix A for description of Type 5.)
16	Visibility in escape routes.	
17	Emergency electrical power supply.	
18	Fire hydrant system.	f A direct connection to the Fire Service is not required provided a telephone is installed and freely available at all times to enable 111 calls to be made.
19	Refuge areas.	
20	Fire systems centre.	

Amend 4
Oct 2005

Amend 7
Nov 2008

Note:
The numbered references are more fully explained in Appendix A. Throughout Table 4.1 dark shading identifies where sprinklers are required.

Amend 7
Nov 2008

Table 4.1/1: Fire safety precautions for active purpose group firecells
Occupant load 100

Purpose group	FHC	Escape height								
		0 m (or single floor)	<4 m (or two floors)	4 m to <10 m	10 m to <25 m	25 m to <34 m	34 m to <46 m	46 m to <58 m	over 58 m	
CS	1	F0	F45	F45	F45	F30	F45	F45	F60	
	2	F0	F60	F60	F60	F45	F45	F60	F90	
	3	F0	F60	F60	F90	F45	F60	F60	F90	
		2af 18c 16	2af 18c 16	3b 9 16 18c	4 9 16 18	6 9 13 15 16 18	7 9 13 15 16 18	7 9 13 15 16 18	7 9 13 15 16 17 18 19 20	
CM	2	F0	F60	F60	F60	F45	F45	F60	F90	
(Note 5)	4	F0	F30	F30	F45	F45	F60	F60	F90	
		2af 18c 16	2af 18c 16	6 18c	3b 9 16 18c	6 9 15 16 18	6 9 13 15 16 18	7 9 13 15 16 18 20	7 9 13 15 16 17 18 19 20	
WL	1	F0	F45	F45	F45	F30	F45	F45	F60	
WM	2	F0	F60	F60	F60	F45	F45	F60	F90	
WH	3	F0	F60	F60	F90	F45	F60	F60	F90	
(Note 5)	4	F0	F30	F30	F45	F45	F60	F60	F90	
		2af 18c 16	2af 18c 16	6 18c	3b 16 18c	6 16 16 18	6 15 16 18	6 9 15 16 18	7 9 13 15 16 18	7 9 13 15 16 18 19 20
WF	4	F0	F30	F30	F45	F45	F60	F60	F90	
		3af 18c 16	6 18c 16	6 16 18c	6 15 16 18	6 15 16 18	6 9 13 15 16 18	7 9 13 15 16 18	7 9 13 15 16 18 19 20	
Column		1	2	3	4	5	6	7	8	

Notes:

- Use of table:** Refer to Paragraph 4.4 for instructions on using this table to determine the *fire safety precautions* in *firecells*.
- Adjoining firecells having a F0 rating:** Paragraph 6.2.1 requires adjoining *firecells* to be separated by *fire separations* with *FRR* no less than 30/30/30.
- Intermediate floors:** Where a *firecell* contains *intermediate floors* a *FRR* shall apply to the *intermediate floors* and supporting elements, and smoke control systems Type 9 and either Type 10 or Type 11, are required (see Paragraphs 4.5.16 to 4.5.18, 6.14.3 and 6.21.5 to 6.22.14).
- Car parking:** Refer to Paragraphs 6.10.3 to 6.10.6 for car parking provisions within *buildings*.
- Sprinklers:** Refer to Paragraphs 5.6.12 and 5.6.13 for concessions for *FHC* 4.
- Visibility in escape routes:** is specified in NZBC Clause F6.

Amend 7
Nov 2008

Amend 7
Nov 2008

Amend 7
Nov 2008

Amend 7
Nov 2008

Amend 4
Oct 2005

Amend 7
Nov 2008

Table 4.1/2: Fire safety precautions for active purpose group firecells
Occupant load 101 to 500

Purpose group	FHC	Escape height								
		0 m (or single floor)	<4 m (or two floors)	4 m to <10 m	10 m to <25 m	25 m to <34 m	34 m to <46 m	46 m to <58 m	over 58 m	
CL (Note 7)	1	F0	F45	F45	F45	F30	F45	F45	F60	
	2	F0	F60	F60	F60	F45	F45	F60	F90	
	3	F0	F60	F60	F90	F45	F60	F60	F90	
		3f 16 18c	3f 16 18c	3b 9 16 18c	4 9 16 18	6 9 13 15 16 18	7 9 13 15 16 18	7 9 13 15 16 18	7 9 13 15 16 17 18 19 20	
CM (Note 5)	2	F0	F60	F60	F60	F45	F45	F60	F90	
	4	F0	F30	F30	F45	F45	F60	F60	F90	
		3f 16 18c	3f 16 18c	6 16 18c	3b 9 16 18c	6 9 15 16 18	3b 9 15 16 18	6 9 13 15 16 18 20	7 9 13 15 16 17 18 19 20	
WL	1	F0	F45	F45	F45	F30	F45	F45	F60	
WM	2	F0	F60	F60	F60	F45	F45	F60	F90	
WH	3	F0	F60	F60	F90	F45	F60	F60	F90	
(Note 5)	4	F0	F30	F30	F45	F45	F60	F60	F90	
		3f 16 18c	3f 16 18c	6 16 18c	3b 16 18c	6 16 18c	3b 15 16 18	6 15 16 18	6 9 15 16 18	7 9 13 15 16 18
WF	4	F0	F30	F30	F45	F45	F60	F60	F90	
		3f 16 18c	6 16 18c	6 16 18c	6 15 16 18	6 15 16 18	6 9 13 15 16 18	7 9 13 15 16 18	7 9 13 15 16 18	
Column		1	2	3	4	5	6	7	8	

Notes:

- Use of table:** Refer to Paragraph 4.4 for instructions on using this table to determine the fire safety precautions in firecells.
- Adjoining firecells having a F0 rating:** Paragraph 6.2.1 requires adjoining firecells to be separated by fire separations with FRR no less than 30/30/30.
- Intermediate floors:** Where a firecell contains intermediate floors a FRR shall apply to the intermediate floors and supporting elements, and smoke control systems Type 9 and either Type 10 or Type 11, are required (see Paragraphs 4.5.16 to 4.5.18, 6.14.3 and 6.21.5 to 6.22.14).
- Car parking:** Refer to Paragraphs 6.10.3 to 6.10.6 for car parking provisions within buildings.
- Sprinklers:** Refer to Paragraphs 5.6.12 and 5.6.13 for concessions for FHC 4.
- Visibility in escape routes:** is specified in NZBC Clause F6.
- CL:** For firecells, which are not cinemas or theatres, with escape height less than 4.0 m and occupant load not greater than 250, Type 2f is a permitted alternative to Type 3f.

Amend 5
Oct 2005

Amend 7
Nov 2008

Amend 7
Nov 2008

Amend 4
Nov 2008

Table 4.1/3: Fire safety precautions for active purpose group firecells
Occupant load 501 to 1000

Purpose group	FHC	Escape height							
		0 m (or single floor)	<4 m (or two floors)	4 m to <10 m	10 m to <25 m	25 m to <34 m	34 m to <46 m	46 m to <58 m	over 58 m
CL	1	F0	F45	F45	F30	F30	F45	F45	F60
	2	F0	F60	F60	F30	F45	F45	F60	F90
	3	F0	F60	F60	F45	F45	F60	F60	F90
	4	4	4	4	7	7	7	7	7
	16	16	16	9	9	9	9	9	9
	18c	18c	18c	16	13	13	13	13	13
				18c	15	15	15	15	15
					16	16	16	16	16
					18	18	18	18	17
									18
								19	
								20	
CM	2	F0	F60	F60	F30	F45	F45	F60	F90
(Note 5)	4	F0	F30	F30	F45	F45	F60	F60	F90
	4	4	6	4	6	7	7	7	7
	16	16	16	9	9	9	9	9	9
	18c	18c	18c	16	16	15	13	13	13
				18c	18c	16	15	15	15
						18	16	16	16
							18	18	17
							20	20	18
									19
									20
WL	1	F0	F45	F45	F30	F30	F45	F45	F60
WM	2	F0	F60	F60	F30	F45	F45	F60	F90
WH	3	F0	F60	F60	F45	F45	F60	F60	F90
(Note 5)	4	F0	F30	F30	F45	F45	F60	F60	F90
	4	4	6	4	6	7	7	7	7
	16	16	16	16	16	15	15	9	9
	18c	18c	18c	18c	18c	16	16	15	13
						18	18	16	15
								18	16
								18	18
									19
									20
WF	4	F0	F30	F30	F45	F45	F60	F60	F90
	4	6	6	7	7	7	7	7	7
	16	16	16	15	15	9	9	9	9
	18c	18c	18c	16	16	13	13	13	13
				18	18	15	15	15	15
						16	16	16	16
						18	18	18	18
									19
									20
Column		1	2	3	4	5	6	7	8

Notes:

- Use of table:** Refer to Paragraph 4.4 for instructions on using this table to determine the fire safety precautions in firecells.
- Adjoining firecells having a F0 rating:** Paragraph 6.2.1 requires adjoining firecells to be separated by fire separations with FRR no less than 30/30/30.
- Intermediate floors:** Where a firecell contains intermediate floors an FRR shall apply to the intermediate floors and supporting elements, and smoke control systems Type 9 and either Type 10 or Type 11, are required (see Paragraphs 4.5.16 to 4.5.18, 6.14.3 and 6.21.5 to 6.22.14).
- Car parking:** Refer to Paragraphs 6.10.3 to 6.10.6 for car parking provisions within buildings.
- Sprinklers:** Refer to Paragraphs 5.6.12 and 5.6.13 for concessions for FHC 4.
- Visibility in escape routes:** is specified in NZBC Clause F6.

Amend 5
Oct 2005
Amend 7
Nov 2008

Amend 4
Oct 2005

Amend 7
Jun 2008

Amend 4
Oct 2005

**Table 4.1/4: Fire safety precautions for active purpose group firecells
Occupant load over 1000**

Amend 7
Nov 2008

Amend 7
Nov 2008

Amend 7
Nov 2008

Amend 7
Nov 2008

Purpose group	FHC	Escape height							
		0 m (or single floor)	<4 m (or two floors)	4 m to <10 m	10 m to <25 m	25 m to <34 m	34 m to <46 m	46 m to <58 m	over 58 m
CL	1	F0	F30	F30	F30	F30	F45	F45	F60
	2	F0	F30	F30	F30	F45	F60	F60	F90
	3	F0	F30	F30	F45	F45	F60	F60	F90
		7 16 18c	7 16 18c	7 9 16 18c	7 9 16 18	7 9 13 15 16 18	7 9 13 15 16 18	7 9 13 15 16 18	7 9 13 15 16 17 18 19 20
CM	2	F0	F30	F30	F30	F45	F45	F60	F90
(Note 5)	4	F0	F30	F30	F45	F45	F60	F60	F90
		7 16 18c	7 16 18c	7 9 16 18c	7 9 15 16 18	7 9 13 15 16 18	7 9 13 15 16 18 20	7 9 13 15 16 18 20	7 9 13 15 16 17 18 19 20
WL	1	F0	F30	F30	F30	F30	F45	F45	F60
WM	2	F0	F30	F30	F30	F45	F45	F60	F90
WH	3	F0	F30	F30	F30	F45	F60	F60	F90
(Note 5)	4	F0	F30	F30	F30	F45	F60	F60	F90
		7 16 18c	7 16 18c	7 16 18c	7 15 16 18	7 15 16 18	7 9 15 16 18	7 9 13 15 16 18	7 9 13 15 16 18 19 20
WF	4	F0	F30	F30	F45	F45	F60	F60	F90
		7 16 18c	7 16 18c	7 16 18c	7 15 16 18	7 15 16 18	7 9 13 15 16 18	7 9 13 15 16 18	7 9 13 15 16 18 19 20
Column		1	2	3	4	5	6	7	8

Notes:

- Use of table:** Refer to Paragraph 4.4 for instructions on using this table to determine the fire safety precautions in firecells.
- Adjoining firecells having a F0 rating:** Paragraph 6.2.1 requires adjoining firecells to be separated by fire separations with FRR no less than 30/30/30.
- Intermediate floors:** Where a firecell contains intermediate floors a FRR shall apply to the intermediate floors and supporting elements, and smoke control systems Type 9 and either Type 10 or Type 11, are required (see Paragraphs 4.5.16 to 4.5.18, 6.14.3 and 6.21.5 to 6.22.14).
- Car parking:** Refer to Paragraphs 6.10.3 to 6.10.6 for car parking provisions within buildings.
- Sprinklers:** Refer to Paragraphs 5.6.12 and 5.6.13 for concessions for FHC 4.
- Visibility in escape routes:** is specified in NZBC Clause F6.

Table 4.1/5: Fire safety precautions for sleeping purpose group firecells
Occupant load 40 maximum

Purpose Group	FHC	Escape height							
		0 m (or single floor)	<4 m (or two floors)	4 m to <10 m	10 m to <25 m	25 m to <34 m	34 m to <46 m	46 m to <58 m	over 58 m
SC SD	1	F0	F30	F30	F30	F30	F45	F45	F60
		7	7	7	7	7	7	7	7
		16	16	16	9	8	8	8	8
		18c	18c	18c	15	9	9	9	9
					16	13	13	13	13
					18	15	15	15	15
						16	16	16	16
						18	18	18	17
						20	20	20	18
									19
								20	
SA (Note 5)	1	F0	F45	F45	F45	F30	F45	F45	F60
		5af	5f	5	5	7e	7e	7e	7e
		16	16	14	14	8	8	8	8
		18c	18c	16	15	9	9	9	9
				18c	16	15	13	13	13
					18	16	15	15	15
						18	16	16	16
							18	18	17
							20	20	18
									20
SR (Note 7)	1	F0	F45	F45	F45	F30	F45	F45	F60
		1	1	1	5	7e	7e	7e	7e
		16			14	15	15	15	13
			2af	2f	16	16	16	16	15
			16	16	18	18	18	18	16
								20	18
								20	
Column		1	2	3	4	5	6	7	8

Notes:

- Use of table:** Refer to Paragraph 4.4 for instructions on using this table to determine the *fire safety precautions* in *firecells*.
- Adjoining firecells having a F0 rating:** Paragraph 6.2.1 requires adjoining *firecells* to be separated by *fire separations* with *FRR* no less than 30/30/30.
- Intermediate floors:** Where a *firecell* contains *intermediate floors* a *FRR* shall apply to the *intermediate floors* and supporting elements, and smoke control systems Type 9 and either Type 10 or Type 11, are required (see Paragraphs 4.5.16 to 4.5.18, 6.14.3 and 6.21.5 to 6.22.14).
- Car parking:** Refer to paragraphs 6.10.3 to 6.10.6 for car parking provisions within *buildings*.
- Sprinklers:** *Purpose group* SA may have an *occupant load* up to 160 beds in *firecells* with a Type 7 alarm (see Paragraph 6.7.2).
- Occupant load in SC and SD firecells:** The *occupant load* in a *group sleeping area firecell* is limited to 12 or 20 beds and in a *suite* to six beds (see Paragraphs 6.6.3 to 6.6.5). For *firecells* (such as an operating theatre) required to remain occupied during a *fire*, see Paragraphs 5.6.8 and 5.6.9.
- SR household units:** See Paragraph 6.8.6 which describes where *household units* containing upper floors may be treated as single floor *firecells*.
- Visibility in escape routes:** is specified in NZBC Clause F6.

Amend 7
Nov 2008

Amend 7
Nov 2008

Amend 7
Nov 2008

Amend 4
Oct 2005

Amend 7
Nov 2008

Acceptable Solution C/AS1

Part 5: Fire Resistance Ratings

5.1 FRR Components

5.1.1 As described in the definitions, a *FRR* comprises three numbers indicating values for *stability*, *integrity* and *insulation*. *Primary* and *secondary elements* required to be *fire* rated will, depending on their function, need to satisfy one or more of these three criteria. The following is an indication of where they apply:

- a) *Stability*: Provided by *primary elements* within a *firecell*. These include *building elements* which are part of the structural frame, and those providing support to other *fire* rated elements within the same or adjacent *firecells*. Examples are: columns, beams, floors and walls (which may also be *fire separations*). Paragraph 5.9.4 describes special situations where *primary elements* need not be rated.
- b) *Integrity*: Provided by *secondary elements*: e.g. *fire separations* being internal walls and floors, areas of *external walls* not permitted to be an *unprotected area*, and some areas of roofs when close to another *building*, or crossed by an *exitway*. *Primary elements* integral with *secondary elements* are also rated for *integrity*.
- c) *Insulation*: Provided by either *primary* or *secondary elements*. Applies to *fire separations* and is required where the transmission of heat through the element may endanger occupants on the other side, or cause *fire* to spread to other *firecells* or *adjacent buildings*.

COMMENT:

For example, *insulation* is necessary for *fire separations* between sleeping spaces or where protecting a *safe path* or through *external walls*. Paragraph 5.6.4 establishes where *insulation* values are required.

Amend 5
Oct 2005 |

5.2 FRR Component Values

5.2.1 The values applied to each of the three components of the *FRR*, depend on the function and location of the *building element* to which the *FRR* applies. In some cases all three numbers (for *stability*, *integrity*, *insulation*) will be the same. In others, the numbers will differ and some may have a value of zero.

For example:

- a) When *F45* or *S45* applies to an isolated column in a *firecell*, the *FRR* is 45/-/-; but if the column is integral with a *fire separation* wall having a *FRR* of 30/30/30, the column *FRR* is 45/30/30.
- b) Where the rating requirements *F45* and *S30* both apply to a *firecell* with an *external wall*, the *S* rating becomes *S45* for *primary elements* and *S30* for *secondary elements*. The appropriate *FRRs* are thus:
 - i) for isolated *primary elements*, 45/-/-,
 - ii) for *secondary elements*, -/30/x, and
 - iii) for *primary elements* integral with *secondary elements* (being *fire separations*), 45/30/x.

Amend 5
Oct 2005

COMMENT:

x represents the *insulation* value required by Paragraph 5.6.4.

Amend 5
Oct 2005

5.2.2 In specific situations this acceptable solution prescribes minimum *FRRs*. However, in most cases it is necessary to derive the *FRR* using the *F* and *S* ratings.

5.3 Application of F and S Ratings

F ratings

5.3.1 *F ratings* apply to *primary* and *secondary elements* within a *firecell*, including walls and floors which are *fire separations*, together with their supporting elements within the same *firecell*.

S ratings

5.3.2 *S ratings* apply to:

- a) *Primary elements* which, within a *firecell*, provide *stability* to an *external wall* not permitted to have 100% *unprotected area* due to:
 - i) proximity of the *building* to a *relevant boundary*, or
 - ii) the configuration of the *building* or siting of *adjacent buildings*, where there is a threat of *fire* spread to sleeping *purpose groups*.
- b) *Secondary elements* forming parts of an *external wall* which are not permitted to be *unprotected areas*.

- c) All *primary elements*, in any *building* with an *escape height* exceeding 25 m (see also Paragraph 5.7.7).
- d) *Fire separations* between *firecells* containing *other property*.
- e) *Fire separations* in *firecells* which require subdivision due to restrictions on floor areas (see Paragraph 4.2.3).
- f) *Buildings* containing car parking (see Paragraph 6.10.3).

5.4 Essential Data for Determining F and S Ratings

5.4.1 *F* and *S ratings* may be obtained from tables once essential data on the *building* and its proposed occupancy are known. It is therefore necessary to determine:

- a) *Escape height* and number of floors.
- b) The number of *firecells* at each floor level. (In most cases each full floor level will be a separate *firecell*.)
- c) Floor area (A_f) of each *firecell*, which will be the sum of the areas of any *intermediate floors* and the lowest floor in the *firecell*.
- d) *Purpose groups* and the floor areas they occupy in each *firecell*.
- e) *Occupant load* in each *firecell*.
- f) *Fire hazard category* in each *firecell*.
- g) Distance between each *external wall* and the *relevant boundary*.
- h) Total area of vertical openings (A_v) in all *external walls* of each *firecell*.
- i) Area of horizontal openings (A_h) in the roof of each *firecell* where relevant.
- j) Whether the *firecell* floor areas comply with the maximum permitted (by Paragraph 4.2.3) for the *fire hazard category* contained.

COMMENT:

See Table 5.1 Note 4 for a description of what comprises effective openings when determining the values of A_v and A_h .

Amend 4
Oct 2005

Amend 4
Oct 2005

Amend 5
Oct 2005

5.5 Determining F and S Ratings

F ratings

5.5.1 *F ratings* are determined directly from Table 4.1.

S Ratings for firecells with FHC 1, 2 and 3

5.5.2 *S ratings* are determined from Table 5.1 using the following process.

5.5.3 For each *firecell* determine the ratios:

$$A_v/A_f \text{ and } A_h/A_f$$

Where:

A_f = area of floor.

A_v = total area of vertical openings in the walls.

A_h = area of horizontal openings in the roof.

The *S rating* is calculated from the formula:

$$S = kt_e$$

Where:

t_e (equivalent time of *fire* exposure in minutes) is determined from Table 5.1, and k is a variable having the following values:

k = 1.0 for unsprinklered *firecells*, or
 = 0.5 for sprinklered *firecells*.

COMMENT:

1. Table 5.1 has been based on unpublished overseas information used to develop a series of Eurocodes for structural *fire* safety design.
2. In contrast to the traditional method of expressing *fire* rating requirements in 30 minute intervals, use of Table 5.1 allows the allocation of a t_e value (and consequentially an *S rating*) ranging anywhere between 30 and 240 minutes in 10 minute intervals.
3. This has the advantage of permitting *fire* resisting *building elements* to be used to their full potential as determined by *standard tests* or calculation methods based on those tests.

For example: A *primary element* tested satisfactorily to 40 minutes for *stability*, would traditionally be rated at 30 minutes, being the next lowest value in the 30 minute interval system. Using Table 5.1 it is possible to adjust the ventilation configuration, if desired, to take advantage of the full 40 minutes.

4. Standard *fire* tests give values for all three criteria of *stability*, *integrity* and *insulation*, and depending on the requirements of a particular *building element*, a low value for one criterion, for example, *insulation*, might not permit higher values for *stability* or *integrity* being utilised.
5. Specific *fire* engineering design may be used as an alternative method for determining *S ratings*, and in some cases may give less conservative results than provided by Table 5.1. A list of relevant Eurocode references is given in the reference section of this Compliance Document.

Amend 5
Oct 2005

5.6 Determining the FRR

5.6.1 Having determined the *F* and *S ratings*, choosing the appropriate numbers for the *FRR* involves:

- a) Identifying the functions of the *building element* in question (e.g. *primary* or *secondary element*, or part of an *external wall* not permitted to be *unprotected area*).
- b) Deciding whether or not *insulation* is required (see Paragraph 5.6.4).
- c) Checking whether specific requirements are imposed elsewhere in this Acceptable Solution for a particular *purpose group* or *building function* (see Paragraphs 5.6.9, 6.3 to 6.11 and Part 7).

Amend 5
Oct 2005

Amend 5
Oct 2005

5.6.2 Following this analysis an appropriate *FRR* may be assigned to each *building element* (see examples given in Paragraph 5.2.1). If an *F rating* and an *S rating* apply to a *building element*, use the higher of the two.

Amend 4
Oct 2005

Applying insulation component in FRR

5.6.3 Where the *building element* is a *fire separation*, the *FRR* of that *fire separation* shall be no less than the *FRR* required by the adjacent *firecell*.

Amend 4
Oct 2005

5.6.4 *Insulation* ratings shall apply to:

- a) All *fire separations*, except as noted in Paragraph 5.6.5 c) and d).
- b) Parts of *external walls* which are not permitted to be *unprotected areas*.
- c) Parts of *external walls* which are within 2.0 m of an *external exitway*.
- d) *Intermediate floors*.

Amend 5
Oct 2005

5.6.5 Where required by Paragraph 5.6.4, the *insulation* value shall be no less than the *F rating*, or the *S rating* if under Paragraph 5.3.2 the *S rating* applies to the *building element*, except that:

Amend 5
Oct 2005Amend 5
Oct 2005

- a) For any part of an *external wall* not permitted to be an *unprotected area*, the value shall be no less than the rating based on the higher of the *F* or *S rating* applicable to the *firecells*.
- b) *Intermediate floors* shall have an *insulation* value as required by Paragraph 6.14.3.
- c) *Insulation* values for closures in *fire separations* are as specified in Table 6.1.
- d) No *insulation* value is required for glazing installed in accordance with Paragraph 5.8.2.

Amend 5
Oct 2005Amend 4
Oct 2005**FRR reductions for sprinklered firecells**

5.6.6 Where sprinklers are installed in a *firecell*, but such installation is not a requirement of Table 4.1, or Paragraph 3.15, the *FRR* of *building elements* may be reduced by no more than 50%.

Amend 4
Oct 2005Amend 7
Nov 2008Amend 4
Oct 2005Amend 4
Oct 2005**COMMENT:**

1. For example: a *FRR* of 60/60/60 may be reduced to 30/30/30, a *FRR* of 60/-/- to 30/-/-.
2. The calculation for *S ratings* automatically takes account of sprinkler installation and no further reductions are permitted.

Amend 4
Oct 2005**Concessions for multiple purpose groups**

5.6.7 When a single *firecell* contains *purpose groups* with different *FRR* requirements for *fire separations*, use either:

Amend 4
Oct 2005

- a) The highest *FRR* throughout the *firecell*, or
- b) The second highest *FRR* throughout the *firecell*, if the percentage given by:

$$\frac{\text{floor area with highest FRR} \times 100}{\text{total firecell floor area}}$$

is no more than:

- i) 20%, or
- ii) 40% if the *firecell* is sprinklered.

5.6.8 The concession permits the use of the second highest *FRR*. This rating may be applied throughout the *firecell*, except that, if not sprinklered, the rating of the floor above shall be no less than that of the *purpose group* with the highest *FRR*. The alarm type and *fire safety precautions* from Table 4.1 shall be those for the *purpose group* requiring the highest degree of protection (see Paragraph 5.6.11 for *FHC* 4 concessions).

Amend 4
Oct 2005Amend 5
Oct 2005**Special requirements for buildings remaining occupied during fire**

5.6.9 Where a *building* evacuation is not possible or desirable although there is a *fire* in one of the *firecells* (e.g. in a hospital operating theatre, civil defence *building* or police station), or in any other situation where security from structural collapse is not related to distance from a *relevant boundary*, the risks shall be evaluated by a *fire engineer* who shall decide whether:

Amend 4
Oct 2005

- a) The higher of the *F* or *S ratings* and associated *fire safety precautions* and subdivision into smaller *firecells* are appropriate, or
- b) The requirements for active and passive *fire* protection are to be determined by *fire engineering design*.

Amend 4
Oct 2005

5.6.10 In such situations the accommodation concerned, the services to it, and the means of escape, shall remain safe for the duration of a fully developed *fire* in an adjacent *firecell*.

Firecells with FHC 4

Amend 4
Oct 2005

5.6.11 Where *fire hazard category 4* applies to a given *purpose group* (see Table 2.1), the *S rating* associated with the *firecell* shall be determined by *fire engineering design*, except that where there are multiple *purpose groups* on that floor, only one of which is in *fire hazard category 4*, the concession available from Paragraph 5.6.12 may apply.

Amend 5
Oct 2005

5.6.12 In a *firecell*, where an area of *FHC 4* is present not exceeding 5% or 20 m², whichever is the lesser of the *firecell* floor area, the overall *FHC* of the *firecell* will remain unchanged as if the *FHC 4* is not present.

Amend 4
Oct 2005

5.6.13

- a) In *buildings* with two or more full floors, or the total aggregated area of the intermediate floors in a *firecell* exceeds 35 m², all floors shall be sprinkler protected.
- b) For a single storey *building* in which an intermediate floor not exceeding 35 m² is provided 5.6.13 a) does not apply, but the *building* shall be considered by specific *fire engineering design* under Paragraph 5.6.11.

COMMENT:

This allows for the provision of a small intermediate floor of up to 35 m² within a *FHC4 firecell* without triggering the requirement to sprinkler protect the *firecell*.

Amend 4
Oct 2005
Amend 7
Nov 2008

COMMENT:

1. A *purpose group* may be in *fire hazard category 4* for one or both of the following reasons:
 - a) The energy density of the *fire load* exceeds that associated with *fire hazard category 3* (an upper limit of around 1500 MJ/m²).
 - b) The *combustible* material in the *firecell* exhibits an overall rate of *fire growth* appreciably greater than that of predominantly cellulose-based products, in particular, materials which have a heat release rate (hrr) of 1 MW or more in less than 75 seconds.

Examples of such materials and heat release rates may be obtained from NFPA 92B, Smoke-management systems in malls, atria and large areas.

2. Both reasons will apply to the uses listed under *fire hazard category 4* for *purpose groups* CM, WH and WF in Table 2.1.
3. Specific *fire engineering design* for *fire hazard category 4* will typically commence with the design of an active protection system. This system must be purpose designed to meet the design *fire hazard* for the particular application and to control a developing *fire*.

5.7 Applying FRRs to Building Elements

General requirements

- 5.7.1** *FRRs* apply to the sides of *primary* and *secondary elements* which are exposed to *fire*.
- 5.7.2** When different *FRRs* apply on each side of a *fire separation*, being a wall, the higher rating shall apply to both sides.
- 5.7.3** Floors shall be rated on the underside (see Paragraph 6.14.2).
- 5.7.4** The *FRR* of a *primary element* integral with a *fire separation* shall be no less than that of the *fire separation*.
- 5.7.5** Except as required by Paragraph 5.7.6, areas of *external wall* not permitted to be *unprotected areas* need be rated only for the threat of *fire* from within a *firecell*.
- 5.7.6** Areas of *external wall* not permitted to be *unprotected areas* shall be rated for *fire exposure* on both sides equally where:
 - a) Walls are within 1.0 m of the *relevant boundary*, or
 - b) *Purpose groups* SC, SD and SA are on one or more floor levels above their *final exit*, or SR is on two or more floor levels above their *final exit*, or
 - c) The *building height* is more than 10 m.

COMMENT:

Refer also to Paragraphs 7.9.10 and 7.9.11 for additional *external wall* requirements for the *purpose groups* referred to in b).

5.7.7 When providing *stability* to *fire rated elements* in an adjacent (above or beside) *firecell*, *primary elements* need be rated only as required for the *firecell* in which they are located, regardless of any higher ratings which may apply to the adjacent *firecell*.

5.7.8 Structural framing members connected to *fire rated primary or secondary elements* shall be rated at no less than the elements to which they are connected, or alternatively their connections and supports shall be designed so that their collapse during *fire* will not cause collapse of the *fire* rated elements.

COMMENT:

Primary elements shall have a *FRR* of no less than that of any *building element* to which they provide support within the *firecell*.

Minimum FRRs

5.7.9 Throughout this acceptable solution minimum *FRRs* are specified for particular situations. It is therefore essential to check for specific requirements, particularly with respect to sleeping *purpose groups* and those with a high *FHC*.

COMMENT:

The following is an abbreviated list of some situations where minimum *FRRs* are specified. Users should always refer to the relevant quoted paragraph before determining *FRR* requirements for individual projects.

	Reference Paragraph
Minimum FRR 15/-/-	
<i>Primary elements</i> of detached open sided <i>building</i> close to <i>boundary</i>	7.8.10
Minimum FRR 15/15/15	
Separation of SC or SD <i>suites</i>	6.6.5
Separation of sprinklered SA <i>group sleeping areas</i>	6.7.2
<i>Intermediate floors</i>	6.14.3
Walls of attached open sided <i>buildings</i> close to <i>relevant boundary</i>	7.8.10
Minimum FRR -/30/30	
<i>Fire separations</i> subdividing ceiling spaces in <i>purpose group</i> SA or SR	6.18.8
Minimum FRR 30/30/30	
Separation of <i>firecells</i> rated F0	6.2.1
Proscenium walls in <i>theatres</i> (CL) with <i>occupant load</i> > 500	6.3.1
Supporting structure in sprinklered enclosed spaces beneath tiered seating (CS, CL, CO)	6.5.2
Separation of SC or SD from other <i>purpose groups</i>	6.6.1

Separation of SC or SD sleeping areas	6.6.2
Separation of SC operating theatres, etc. from other SC activities	6.6.6
Separation of support functions with <i>FHC</i> >1 from other SC or SD activities	6.6.7
Separation of SA from other <i>purpose groups</i> , but <i>FRR</i> based on <i>F rating</i> if that is greater	6.7.1
Separation between unsprinklered SA <i>purpose group sleeping areas</i>	6.7.2
Separation between SA <i>suites</i> located on the same floor level	6.7.6
Separation of SR <i>household units</i> , or based on <i>F rating</i> if that is greater	6.8.1
<i>Safe paths</i> (IE) with an <i>escape height</i> of no more than 10 m, but based on <i>F rating</i> if that is greater	6.9.2
Separation, at <i>final exit</i> level, between upper and lower vertical <i>safe paths</i> , but based on <i>F rating</i> if that is greater	6.9.3
Separate IA <i>firecells</i> , or based on <i>F rating</i> of adjacent space if that rating is higher	6.10.1
Separation of <i>protected shafts</i> , or based on highest <i>F rating</i> of adjacent <i>firecells</i>	6.16.2
Parapet for roof car parking or storage <i>FHC</i> < 3	7.8.2
Wall and eaves for SH or SR where eaves within 650 mm of the <i>boundary</i>	7.8.5
Roof within 3.0 m of an external <i>exitway</i> (IE) sprinklered <i>firecells</i>	7.9.3
Walls of small <i>buildings</i> (maximum 40 m ² and <i>FHC</i> 1) within 1.0 m of <i>relevant boundary</i>	7.10.5
<i>External walls</i> of SH or SR within 1.0 m of the <i>boundary</i> , limited to 10 m <i>escape height</i>	7.10.6
<i>External walls</i> of SR <i>household units</i> not permitted to be <i>unprotected area</i>	7.10.7
Minimum FRR 45/45/45	
Unsprinklered <i>firecell</i> <i>FHC</i> 1 tiered seating	6.5.1
Separation of other spaces from sleeping areas	6.7.5
Minimum FRR 60/60/60	
Unsprinklered <i>firecell</i> <i>FHC</i> 2 between tiered seating	6.5.1
Separation of solid waste storage (IA) from other <i>purpose groups</i>	6.10.2
Separation of ID <i>firecells</i> (excluding those containing solid fuel, gas or petroleum powered plant) from other <i>purpose groups</i>	6.11.1

Separation of ID *firecells* containing plant powered by solid fuel, gas or petroleum products, from *purpose groups* other than SC or SD 6.11.3

Basement floors in other than *household units* in *purpose groups* SH and SR 6.14.4

Parapets for roof car parking or storage *FHC* > 2 7.8.2

Roof within 3.0 m of an external *exitway* (IE) unprinklered *firecell* 7.9.3

Minimum FRR 90/90/90

Separation of ID *firecells*, containing plant powered by solid fuel, gas or petroleum products, from SC or SD *firecells* 6.11.3

Amend 5
Oct 2005

5.8 Glazing in Fire and Smoke Separations

Fire separations

5.8.1 Glazing in *fire separations* shall be fixed *fire resisting glazing* having the same *integrity* and *insulation* values as the *fire separation*, except where uninsulated glazing is permitted by Paragraph 5.8.2.

5.8.2 Uninsulated *fire resisting glazing*, having the same *integrity* value as the *fire separation*, is permitted in:

- a) *External walls* for Type B areas of *fire resisting glazing* meeting the requirements of Paragraph 7.4, and
- b) *Fire separations* for sprinklered *firecells* as described in Paragraphs 5.8.7 and 5.8.8, and
- c) *Safe paths* complying with Paragraphs 5.8.3 to 5.8.6 provided that where the *safe path* is an internal *stairway*:
 - i) that *stairway* serves no more than 4 floor levels, and
 - ii) the *building* does not contain *purpose groups* SC, SD, SA or SR, and
 - iii) two or more *escape routes* are available.

Safe paths

5.8.3 Limited areas of uninsulated *fire resisting glazing* may be used in *fire separations* between the *safe path* and adjacent *firecells*. Where only a single *safe path* is provided no glazing shall be permitted within 2.0 m of the floor level (see Figure 5.1 (b)). Where two or more *safe paths* are provided:

- a) The glazing dimensions within 2.0 m of the floor level shall be no greater than permitted by NZS 4232: Part 2 for the chosen separation and the path of travel within the *safe path*, and
- b) Glazing lengths shall be limited and, in the direction of escape, alternate with unglazed lengths of no less than twice the length of the glazed opening (see Figure 5.1 (a)).

Figure 5.1: Glazing in Safe Paths
Paragraphs 5.8.3 and 5.8.5

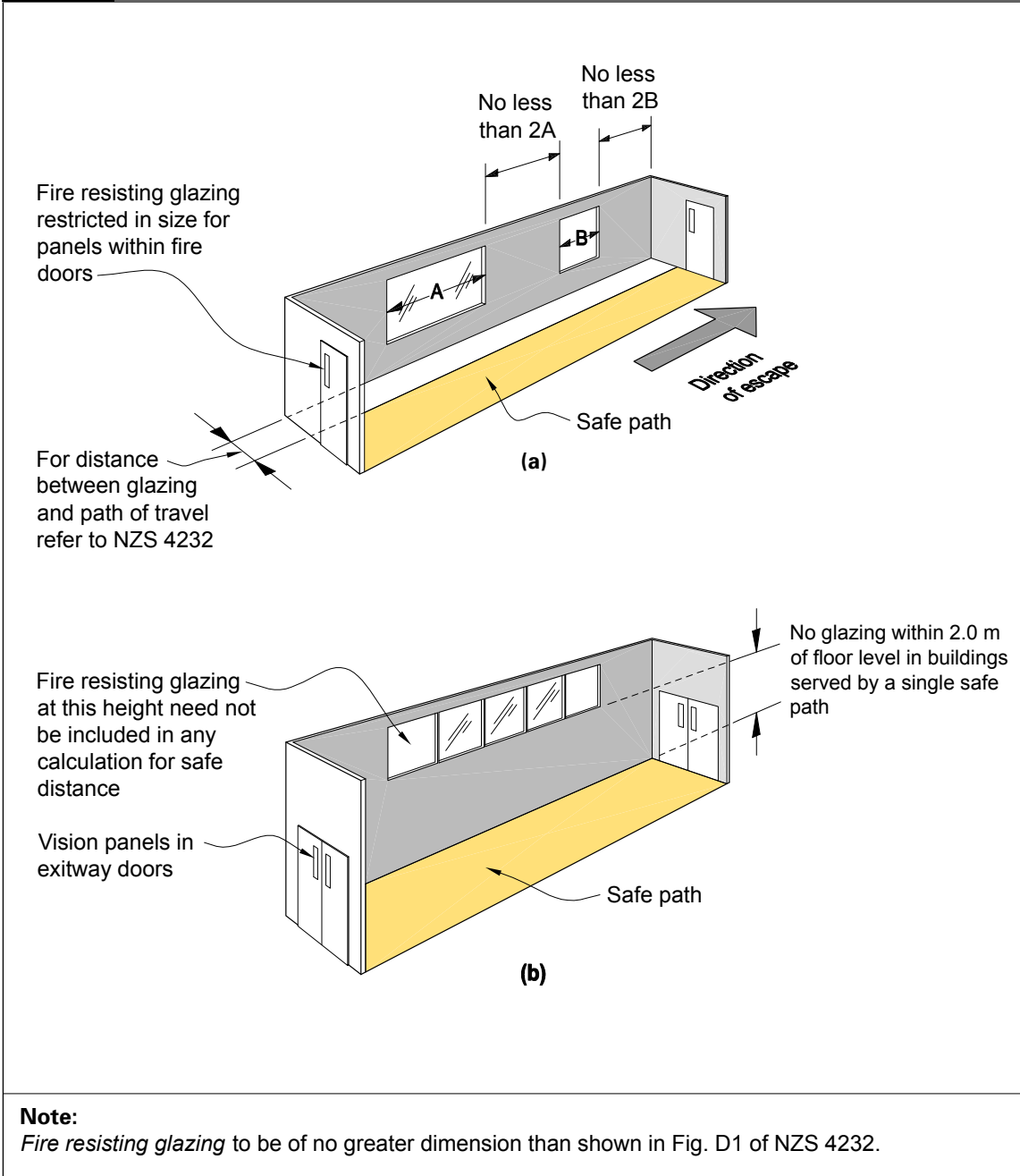

5.8.4 In calculating glazing dimensions from NZS 4232, Figure D1 shall be used with the lower *fire intensity* applying to all *purpose groups* except WH and WF to which the higher *fire intensity* shall apply. The assumed speed of travel in *safe paths* shall be no more than 0.6 m/s.

5.8.5 There is no restriction on the area of uninsulated *fire resisting glazing* located more than 2.0 m above floor level (see Figure 5.1 (b)).

COMMENT:

It is assumed that thermal radiation from glazing more than 2.0 m above floor level will not be a threat during the time it takes occupants to escape.

5.8.6 Where the *safe path* is glazed on both sides, the separation distance when applying Paragraph 5.8.3 a) needs to be calculated only from one side.

COMMENT:

It is assumed that a *fire* in its early stages of development will not have spread to *firecells* on both sides of the *safe path*. It is also assumed the *fire* will not occur within a *safe path*.

Concession for sprinklers

5.8.7 Where the *firecell* adjoining the *safe path* is sprinklered, the glazing area permitted by Paragraph 5.8.3 a) may be doubled.

5.8.8 Where, *firecells* (but not including a *safe path*) on both sides of a *fire separation* are sprinklered, the separation is permitted to have an unrestricted area of uninsulated *fire resisting glazing*.

This provision does not apply to glazing in proscenium walls (see Paragraph 6.19.11).

Smoke separations

5.8.9 There is no restriction on area of glazing in *smoke separations* (including *protected paths*). Non-*fire resisting glazing* may be used if it is toughened or laminated safety glass. Glazing shall have at least the same smoke stopping ability as the *smoke separation*.

Fire doors and smoke control doors

5.8.10 Glazing in *fire doors* shall be *fire resisting glazing* meeting the provisions of Table 6.1. Where an *insulation* value is required, an uninsulated vision panel may be used without downgrading the *insulation* value of the door. Vision panels shall comply with NZS 4520.

Amend 9
Oct 2011

COMMENT:

1. Table 6.1 permits uninsulated *fire resisting glazing* only where *firecells* are sprinklered.
2. Uninsulated *fire resisting glazing* would include wired glass and some clear glasses. There are currently available clear glasses which can achieve an *insulation* rating.
3. NZS 4520 permits a single vision panel of area not exceeding 65,000 mm².

Amend 9
Oct 2011

5.8.11 Glazing in *smoke control doors* shall meet the requirements of Paragraph 5.8.9 for *smoke separations*.

5.9 Structural Stability During Fire

Primary element loadings

5.9.1 To meet the Performances of NZBC C4, this acceptable solution provides for the structural *stability* of *primary elements* by requiring that they be *fire* rated to avoid premature failure.

5.9.2 During a *fire primary elements* shall, resist collapse under:

- a) The design dead and live loads required by NZBC B1, and
- b) Any additional loads caused by the *fire*.

COMMENT:

1. NZBC B1 Clause B1.3.3 (c) and (i) requires that structural *stability* take account of temperature and *fire* effects.
2. Additional loadings can arise from changes in length or other deformations in *building elements* as a result of high temperatures.

(Continued over page)

3. Except with timber members, yield strength generally reduces with temperature increase, so that strength reduction is related to the time for which the *primary element* is exposed to *fire*. Factors which need to be taken into account include the maximum temperature attained, the capacity of the element to absorb heat, potential loss of section, the degree of exposure, whether any applied coating is used to protect the element from the effects of *fire*, and the degree of restraint provided by the surrounding structure.

5.9.3 Factors influencing the necessary level of *fire* resistance include:

- a) *Fire* severity
- b) *Building* height
- c) Total *fire* load
- d) *Purpose* group
- e) *Occupant* load
- f) Capability of a local Fire Service
- g) Availability of a water supply
- h) Level of *fire safety precautions* installed in the *building*.

Unrated primary elements

5.9.4 In nearly all cases (see Paragraph 5.1) *primary elements* are rated for *stability*, and sometimes for *integrity* and *insulation*. However, *primary elements* need not be rated where any of the following circumstances exist:

- a) They are located outside an *external wall* which is 2.0 m or more from the *relevant boundary*, and are shielded from the effects of *fire* by protected areas of the wall (see Figure 5.2), or can be shown by *fire* engineering design to retain *stability* when subjected to thermal radiation and/or flame impingement as appropriate.

COMMENT:

To be shielded from the effects of an internal *fire* by protected areas of the *external wall*, *primary elements* should be placed within a 45° triangle formed in plan by lines drawn from the edges of *unprotected areas* on each side of the element. An alternative approach is to apply a method for determining the *stability* of *primary elements* outside the *external wall* contained in "Fire-safe structural steel – A design guide" – American Iron and Steel Institute. This approach is applicable to *primary elements* of any material.

- b) They are added to strengthen an existing *building* and are required only to carry horizontal loads induced by wind or earthquake.

COMMENT:

1. Usually frame action provides *stability* for the vertical and horizontal loads, and the two are therefore inseparable, but, when strengthening earthquake risk *buildings* for example, structural elements may be required only to withstand horizontal loading.
2. It is assumed that an earthquake will not occur during a *fire*.
- c) They are part of a *building* which is more than 1.0 m from the *relevant boundary* and contains only *purpose* group SH.

COMMENT:

Table 4.1 allows zero *F* rating for single floor *firecells*, provided other *fire safety precautions* are adopted. However, Paragraph 6.2.1 requires those *firecells* to be separated from each other by *fire separations* with a *FRR* of no less than 30/30/30.

Amend 4
Oct 2005

Figure 5.2: Permissible Positioning of Unrated Primary Elements
Paragraph 5.9.4 a)

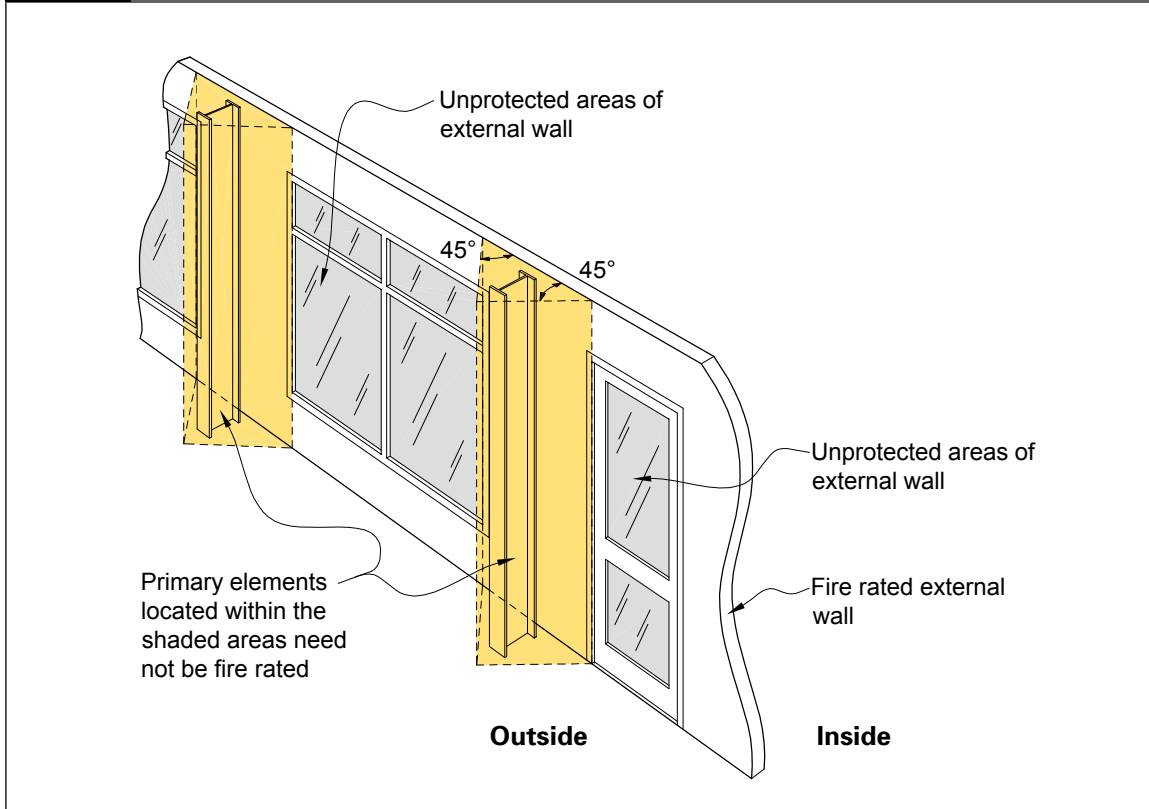

Providing stability

5.9.5 Primary elements required to be fire rated shall have their stability provided in one or more of the following ways:

- a) Be cantilevered from a structural base having a FRR of no less than that of the primary element concerned.
- b) Be supported within the firecell by other primary elements which have a FRR of no less than that required for the primary element being supported.

COMMENT:

The stability to a beam or fire separation may, for example, be provided by beam or diaphragm action of a floor or wall which is rated only for stability.

- c) Be supported by non-fire rated or fire rated primary elements outside the firecell.

COMMENT:

1. It is assumed that fire will be restricted to the firecell of origin at least for the time required by the structural fire endurance rating of the primary element concerned.
2. Refer to B1/VM1 Paragraph 2.2 which quotes NZS 4203 as a means of verifying compliance with the NZBC loading requirements. NZS 4203 Clause 2.4.3.4 b) requires the residual structure, after being subject to fire, at ambient temperatures to resist a combination of gravity load, reduced live load and a uniformly distributed face load of 0.5 kPa.

Fire resistance tests

5.9.6 The FRR of primary elements shall be determined using one of the standard tests given in Appendix C Paragraph C7.1.

Table 5.1: Values of t_e for Calculating the S Ratings for Fire Hazard Categories 1, 2 and 3
Paragraphs 2.2.1, 5.5.2, 5.5.3, 6.10.5, 6.20.15

A_v/A_f	Fire Hazard Category 1 (FLED = 400 MJ/m ²)					Fire Hazard Category 2 (FLED = 800 MJ/m ²)					Fire Hazard Category 3 (FLED = 1200 MJ/m ²)				
	A_h/A_f					A_h/A_f					A_h/A_f				
	0.00	0.05	0.10	0.15	0.20	0.00	0.05	0.10	0.15	0.20	0.00	0.05	0.10	0.15	0.20
0.05 or less	90	60	50	40	40	180	120	100	80	80	240	180	140	140	120
0.06	80	50	50	40	40	160	110	90	80	80	240	160	140	120	110
0.07	70	50	40	40	40	150	100	80	80	70	220	160	140	120	110
0.08	70	50	40	40	30	140	90	80	70	70	220	140	120	110	100
0.09	60	40	40	30	30	140	90	80	70	70	200	140	110	110	100
0.10	60	40	40	30	30	120	80	70	70	70	180	140	110	100	100
0.11	50	40	30	30	30	110	80	70	70	60	160	120	110	100	100
0.12	50	40	30	30	30	100	70	70	60	60	160	110	100	100	90
0.13	50	40	30	30	30	100	70	70	60	60	160	110	100	90	90
0.14	50	30	30	30	30	90	70	60	60	60	140	100	100	90	90
0.15	40	30	30	30	30	80	70	60	60	60	120	100	90	90	90
0.16	40	30	30	30	30	80	60	60	60	60	110	100	90	90	90
0.17	40	30	30	30	30	80	60	60	60	60	110	90	90	90	90
0.18	40	30	30	30	30	70	60	60	60	60	110	90	90	90	80
0.19	30	30	30	30	30	70	60	60	60	60	110	90	90	80	80
0.20	30	30	30	30	30	70	60	60	60	60	100	90	80	80	80
0.25 or greater	30	30	30	30	30	60	60	50	50	50	90	80	80	80	80

Notes:

1. Determining S rating

$S = kt_e$ where $k = 1.0$ for unsprinklered *firecells* and 0.5 for sprinklered *firecells*. Therefore in this table the t_e values are the same as the *S ratings* for unsprinklered *firecells*.

2. Interpretation

A_f = floor area of *firecell* (m²)

A_v = area of vertical openings in *external walls* of the *firecell* (m²)

A_h = area of horizontal openings in roof of *firecell* (m²)

Linear interpolation is permitted where values of A_v/A_f or A_h/A_f lie between those given in the table.

3. Location of openings

Openings to allow *fire* venting should be located in the most practicable manner to provide effective cross-ventilation. This reduces structural *fire* severity and facilitates *fire* fighting operations.

4. Effective openings

a) Only those areas of *external walls* and roofs which can dependably provide airflow to and from the *fire* shall be used in calculating A_v and A_h . Such areas include windows containing non-*fire* resistant glass and likely to break shortly after exposure to significant heat.

b) An allowance can be made for air leakage through the *external wall* of the *building* envelope. The allowance for inclusion in A_v shall be no greater than 0.1% of the *external wall* area where the wall is lined internally, and 0.5% if unlined.

c) Only roof venting which is specifically designed to open or melt rapidly in the event of *fire* shall be included in the area A_h .

d) For single floor *buildings* or the top floor of multi-floor *buildings*, where the structural system supporting the roof is non-rated and directly exposed to the *fire* (i.e. no ceiling installed), A_h/A_f may be taken as 0.2.

5. Areas not regarded as openings

For the purpose of calculating A_v it shall be assumed that doors in *external walls* are closed. Wall areas clad in sheet metal shall not be included in the area A_v .

6. Intermediate floors

Where a *firecell* contains *intermediate floors*, separate calculations shall be made to determine t_e , first by taking A_f as the total floor area in the *firecell* (as defined in Paragraph 2.3.3), then by taking A_f separately as the floor area of each level. The highest value of t_e shall be used to determine the *S rating*.

7. Background to table

Table 5.1 is derived using Equation E3 from Annex E, Eurocode DD ENV 1991-2-2: 1996, Eurocode 1: Basis of Design and Actions on Structures, Part 2.2 Actions on Structures Exposed to Fire (together with United Kingdom National Application Document); British Standards Institution, London, England. A *firecell* height of 3.0 m has been assumed and a thermal inertia factor corresponding to the most severe conditions (i.e. those which generate the highest t_e values and which correspond to use of $k_b = 0.09$ in Equation E3) for typical materials of *firecell* construction. For *firecells* which differ from these assumptions, especially with regard to the materials of construction, more accurate answers may be obtained with specific *fire* engineering design, which is mandatory for *fire hazard category* 4.

Acceptable Solution C/AS1

Part 6: Control of Internal Fire and Smoke Spread

6.1 General

6.1.1 The extent to which internal *fire* and smoke spread shall be controlled, and the methods adopted, depend mainly on the *purpose groups* and activities within the *building*. Control is generally required only for the time required for occupants to escape to a *safe place*. However, the Act Section 4(2)(i) requires the provision of protection to limit the extent and effects of the spread of *fire* to *household units*, other residential units and *other property*.

6.1.2 Control is achieved by using one or more of the following:

- a) Subdividing *firecells* into smaller *firecells* or *smokecells*.
- b) Separating high risk activities from other activities, especially from sleeping *purpose groups*.
- c) Ensuring the *integrity* of *construction* joints and closures in *fire separations* and *smoke separations*.
- d) Preventing the movement of *fire* and smoke through *concealed spaces* and services ducts.
- e) Using appropriate materials and *surface finishes*.
- f) Installing equipment which, when *fire* occurs, activates automatically to suppress *fire* and smoke spread.

6.2 Firecells Rated F0

6.2.1 Where adjacent *firecells* on the same floor level are permitted by Table 4.1 to have a *F rating* of F0, they shall be *fire separated* from one another. The *fire separations* shall have a *FRR* of no less than that required by Part 6 or Part 7 (for a specific *purpose group* or situation), or 30/30/30, whichever is the greater.

COMMENT:

1. Although Table 4.1 provides a *firecell rating* of F0 for all single floor *firecells*, by definition *firecells* must be *fire separated* from one another. The main reason for having separate *firecells* is to provide for *purpose groups* having different *fire safety precautions*. Also, within sleeping *purpose groups*, Paragraphs 6.6 to 6.8 have requirements for certain activities to be *fire separated* and, for *fire separations* to limit the number of occupants in a *firecell*. Within active *purpose groups*, Table 4.1 has different *fire safety precautions* within a *firecell* depending on the *occupant load*.
2. In the absence of *fire separations* on a single floor, the space must be treated as a single *firecell* and the *fire safety precautions* for the primary *purpose group* (see Paragraph 2.2.2) must apply throughout the floor.

6.3 Purpose Groups CS and CL

Theatres

6.3.1 In every *theatre* where the *occupant load* in the auditorium is greater than 500, the stage area (including workshops, storerooms, scenery docks, property, wardrobe or painting rooms used in connection with the *theatre*), shall be separated from the auditorium by a proscenium wall meeting the requirements of a *fire separation* having an *FRR* of no less than 30/30/30. Where the stage and supporting areas are sprinklered as required by Paragraph 6.3.2, the proscenium wall and curtain may be a *smoke separation*. The openings in *fire rated* proscenium walls shall be protected as required by Paragraph 6.19.9.

COMMENT:

In determining the number of occupants on the floor, *occupied spaces* providing support functions need not be included.

Theatre stages

6.3.2 *Theatres* with an *occupant load* of greater than 1000, shall satisfy all the following requirements:

Amend 5
Oct 2005

Amend 4
Oct 2005

- a) Where the stage area is greater than 50 m², a sprinkler system shall be installed at the ceiling above the stage, and in all spaces used for support activities.
- b) Have roof vents of no less than 5% of the stage floor area, located at the highest point above centre stage.
- c) The vents shall have a positive device to keep them closed, and may be of the counterbalanced shutter type, inclined falling type, centre pivot sash type or counterbalanced skylight type.
- d) The vents shall be held normally in a closed position by a heat sensing device installed below the vent opening and its controls, but above the discharge of any sprinkler head in the vicinity.
- e) Vents shall be capable of being operated by a manual control located near the stage safety curtain release.
- f) The heat sensing device required by d) above, shall be interlocked with any heating or ventilating system, so that when activated, it closes all *fire dampers* in all ducts passing through the proscenium wall.

6.4 Purpose Group CM

6.4.1 When the *occupant load* on a sales, exhibition or trade fair floor is greater than 500, adjacent storage areas in which goods are received, unpacked, stored, packed for despatch, or areas used for workshops, and display material storage etc. shall be *smokecells* separated from the display and sales areas.

COMMENT:

1. This applies particularly to exhibition and trade fair halls.
2. Sprinkler requirements for *purpose group* CM are obtained from Table 4.1.

6.5 Purpose Group CO, CS and CL

6.5.1 If not sprinklered any enclosed useable space beneath tiered seating shall be a *firecell* with a rating of *F 45* for *FHC 1* and *F 60* for *FHC 2*.

6.5.2 If any enclosed useable space beneath tiered seating is sprinklered, it need not be a separate *firecell*, but supporting structure of the tiered seating shall have an *FRR* of 30/30/30.

Amend 4
Oct 2005

6.6 Purpose Groups SC and SD

6.6.1 *Firecells* containing *purpose groups* SC and SD shall be separated from *firecells* containing other *purpose groups*, by *fire separations* having a *FRR* of no less than 60/60/60 or 30/30/30 if the adjacent *firecell* is sprinklered.

Amend 4
Oct 2005

6.6.2 Sleeping areas in *purpose group* SC or SD shall be separate *firecells* but may include direct support functions (see Paragraph 6.6.7). *Fire separations* between non-sleeping areas and sleeping areas, and between adjacent sleeping areas, shall have an *FRR* of no less than 30/30/30.

Amend 4
Oct 2005

Group sleeping areas

6.6.3 Where SC or SD *purpose group* sleeping accommodation is contained within only a single *group sleeping area firecell*, the number of beds shall not exceed 12. Where the sleeping accommodation is distributed over two or more *group sleeping area firecells*, each *firecell* shall:

- a) Contain no more than 20 beds, and
- b) Have sufficient space to accommodate, in an emergency, the beds from an adjacent *firecell* of any occupants unable to walk.

Comment:

1. In this acceptable solution the term "beds" is used to denote the number of people expected to be sleeping in the *firecell*. Therefore, a double bed counts as two beds, and a tier of three single bunks (one above another) counts as three beds.
2. When it is not possible or desirable to evacuate occupants from sleeping areas and operating theatres, special considerations may be required. Refer to Paragraph 5.6.9.

Amend 5
Oct 2005

6.6.4 A *group sleeping area firecell* in *purpose group* SC or SD may be subdivided by either:

- a) Non-*fire* rated partitions having a gap of no less than 400 mm between the top of the partitions and the underside of the roof or ceiling, or

- b) Full height *smoke separations* including *smoke control doors* which need not be fitted with self-closers.

COMMENT:

In certain specific situations the *smoke control door* need not be fitted with a self-closer. Typical examples of such situations would be residential care premises or a hospital.

Amend 7
Nov 2008

Suites

6.6.5 Where sleeping areas in SC and SD *purpose groups* are subdivided to create *suites*, each *suite* shall contain no more than 6 beds. Each *suite* shall be a separate *firecell* with *fire separations* having a *FRR* of 15/15/15. *Suites* may be subdivided with non-*fire* rated *construction* to provide separate spaces for sleeping, sanitary facilities and other activities. Where sanitary facilities are shared, those facilities may be contained within one of the *suites*, but entry from other *suites* must be through *fire separations*.

Special care facilities

6.6.6 Hospital operating theatres, delivery and recovery rooms, and intensive care units shall be:

- a) Contained in separate *firecells* having *fire separations* with a *FRR* of no less than 30/30/30, or
- b) Grouped together within a *firecell* which is separated from other activities in the *purpose group* by *fire separations* with a *FRR* of no less than 30/30/30. Within that *firecell*, each space shall be separated from adjacent spaces by *smoke separations*.

Support and service functions

6.6.7 Intermittently *occupied spaces* used for direct support functions to SC and SD *group sleeping areas* may be included in those *firecells*, except that, where direct support functions have a *FHC* greater than 1, these spaces shall be separate *firecells* having *fire separations* with a *FRR* of no less than 30/30/30.

Amend 4
Oct 2005

COMMENT:

Direct support functions include treatment rooms, tea bays, and sanitary facilities essential to the operation of the sleeping area.

6.6.8 Spaces providing communal service functions to adjacent SC and SD sleeping areas in the same *building*, shall be sprinklered and *fire* separated from the sleeping areas with *fire separations* complying with Paragraph 6.6.2.

COMMENT:

Communal service functions include nurses stations, waiting rooms, lounges, dining rooms and staffed kitchens supporting the operation of sleeping areas.

6.6.9 Service vehicle loading and unloading areas within the perimeter walls of a *building* shall meet the requirements of Paragraphs 6.10.3 to 6.10.5.

6.7 Purpose Group SA

6.7.1 *Firecells* containing *purpose group SA* shall be separated from *firecells* in other *purpose groups* by *fire separations* having a *FRR* derived from the *F* rating (given in Table 4.1/5), or 30/30/30 whichever is the greater. (See Paragraph 5.6.6 for *FRR* reductions where sprinklers are installed.)

Amend 7
Nov 2008

Group sleeping areas

6.7.2 *Group sleeping areas* in SA *purpose group* shall be *fire* separated from each other and from non-sleeping areas. *Fire separations* between *group sleeping areas* and non-sleeping areas, and between adjacent *group sleeping areas*, shall have a *FRR* of not less than 30/30/30. Each *group sleeping area firecell* shall contain no more than 40 beds if unsprinklered, or 160 beds in *firecells* with *FSP* Type 7 installed.

Amend 4
Oct 2005

COMMENT:

1. In this acceptable solution the term "beds" is used to denote the number of people expected to be sleeping in the *firecell*. Therefore, a double bed counts as two beds and a tier of three separate bunks (one above another) counts as three beds.
2. *Group sleeping areas* of up to 40 beds might include accommodation such as ski lodges or school dormitories. Larger bed numbers, up to the 160 maximum, would apply to group gatherings in a *wharehenui* or a sleep-over for students in a school hall.

6.7.3 A *group sleeping area firecell* in *purpose group SA* may be subdivided provided that:

- a) The *firecell* contains no more than 40 beds, whether or not sprinklers are installed, and
- b) There is a gap of no less than 400 mm between the top of all partitions and the underside of the roof or ceiling. The partitions need not be *fire* rated.

6.7.4 Intermittently *occupied spaces*, such as tea bays and sanitary facilities, which provide direct support functions to the sleeping area, may be included in a *SA group sleeping area firecell*.

6.7.5 Spaces such as storerooms, laundry facilities, communal kitchens, dining rooms and lounges shall be separated from sleeping areas with *fire separations* having a *FRR* of no less than 45/45/45. It is acceptable for these non-sleeping activities to share a common *firecell*. (See Paragraph 5.6.6 for *FRR* reductions where sprinklers are installed.)

Suites

6.7.6 A sleeping area in *purpose group SA* may be subdivided into separate *suites* (such as a motel unit or hotel room with or without en-suite facilities). Each *suite* shall be a separate *firecell* and contain no more than 12 beds. *Fire separations* between adjacent *suites* on the same floor level shall have a *FRR* of no less than 30/30/30.

COMMENT:

1. It is implicit that within a *suite* containing *SA purpose group*, there is a substantial degree of responsible self regulation by the occupants. Where there are two or more occupants it is expected that the social cohesion of the group would result in a mutual responsibility for warning each other of a *fire* within a *suite*.
2. See Paragraph 2.2.9 for situations where *SA* may be treated as *SR* or *SH*.

6.7.7 Where *SA firecells* are located on an upper floor, *firecells* on lower floors shall have alarm systems in accordance with Paragraphs 4.5.10 to 4.5.12.

6.7.8 Service vehicle and unloading areas within the perimeter walls of a *building* containing *purpose group SA*, shall meet the requirements of Paragraphs 6.10.3 to 6.10.5.

COMMENT:

Service vehicles include commercial vehicles such as delivery vans, refuse pick-up vehicles and the like.

Halls and wharenuī

6.7.9 A hall or *wharenuī* used for sleeping, even if only occasionally, shall be classified as a *group sleeping area purpose group SA*.

COMMENT:

1. See Paragraph 3.3.2 h) which requires wider *escape routes* and Paragraph 3.4.2 e) which requires shorter *open path* lengths in *wharenuī* with specific *surface finishes*.
2. Paragraph 6.7.2 limits the maximum numbers permitted to sleep in a *group sleeping area* such as a *wharenuī*.

6.8 Purpose Groups SR and SH

6.8.1 Every *household unit* in *purpose group SR* shall be a single *firecell* separated from every other *firecell* by *fire separations* having a *FRR* derived from the *F rating* in Table 4.1/5, or 30/30/30, whichever is the greater.

COMMENT:

Where the *building* is separated into unit titles the requirements of Paragraph 7.2.1 a) apply.

6.8.2 An individual *SH* or *SR household unit* may contain one or more upper floors provided that the *open path* length provisions of Table 3.3 are satisfied.

COMMENT:

1. For *purpose groups SR* and *SH*, Table 3.3 permits maximum lengths of 24 m for the *dead end*, and 60 m for the total *open path* where no *FSPs* are installed.
2. See Paragraphs 1.3.3 and 1.3.4 for other *purpose group SH* requirements.

Amend 4
Oct 2005

Amend 4
Oct 2005

Amend 5
Oct 2005

Amend 4
Oct 2005

Amend 7
Nov 2008

6.8.3 Service vehicle loading and unloading areas within the perimeter walls of a *building* containing *purpose group* SR, shall meet the requirements of Paragraphs 6.10.3 to 6.10.5.

COMMENT:

Service vehicles include commercial vehicles such as delivery vans, refuse pick-up vehicles and the like.

6.8.4 Where a car parking garage is provided solely for the use of the occupants of an individual *household unit* in *purpose group* SR, it is acceptable for that garage to be included within the *household unit firecell*. However, where garaging is provided for vehicles of occupants of more than one *household unit*, that space shall be a separate *firecell* complying with the requirements of Paragraphs 6.10.3 to 6.10.5.

6.8.5 For *purpose group* SR, Table 4.1/5 describes the required *fire safety precautions*, and Paragraphs 7.10.6 to 7.10.8 describe the *fire* rating requirements for *external walls*.

6.8.6 Each *household unit* in *purpose group* SR, whether or not containing upper floors, shall be treated as a single floor *firecell* when applying Table 4.1/5 to determine the required *fire safety precautions*.

COMMENT:

1. This means that for individual SR *household units* located only side by side at ground level, the only *fire* safety requirement is for *fire separations* (*FRR* no less than 30/30/30) between adjoining units. See Paragraph 6.2.1 concerning F0 rated *firecells*.
2. For three or more *household units* vertically one above the other, the provisions of Table 4.1/5 apply to all units in the *building*.

6.9 Purpose Group IE

6.9.1 *Exitways* unless external and separated by distance, shall comprise *protected paths* which are *smokecells*, and/or *safe paths* which are *firecells*. Restrictions on the length of *protected paths* are given in Paragraph 3.4.

6.9.2 The *safe path* shall be separated from all adjoining *firecells* by *fire separations* having the same *FRR* throughout its length. The *FRR* shall be the greater of *F* 30 or the *F* rating of the highest rated adjoining *firecell* as determined by Table 4.1.

6.9.3 *Safe paths* which are stairs leading from lower floors or *basements* and which continue to floors above the level of the *final exit*, shall have the lower levels *fire* separated from the *final exit* level. The *fire separation* shall have a *FRR* of 30/30/30, or that required for the lower level, whichever is the greater.

6.9.4 *Safe paths* which are long corridors shall be subdivided by *smoke separations* in accordance with Paragraph 6.13.

6.9.5 Air ducts passing through *exitways* shall not include *combustible* materials.

Ventilation in enclosed exitways for purpose groups SC, SD, SR and SA

6.9.6 Where pressurisation complying with AS/NZS 1668: Part 1 is not provided, for *purpose groups* SC, SD, SR and SA, *exitways* serving two or more *suites* or *household units* shall be ventilated in accordance with Paragraphs 6.9.7 and 6.9.8 except that, no ventilation is required when any of the following conditions occur:

- a) The *suite* or *household unit* opens directly into a *safe path* or *protected path*, not shared by any other *suite* or *household unit*, before reaching a shared *exitway*, or
- b) The *escape height* is no greater than 4.0 m, or
- c) Upon leaving the *suite* or *household unit*, there is more than one direction of escape, or

Amend 5
Oct 2005

Amend 4
Oct 2005

- d) The *suites* or *household units* or *exitways* are sprinklered, or
- e) The length of that part of an *escape route* through the shared *exitway* before passing through another *smoke separation* and *smoke control door* is no greater than 5.0 m.

COMMENT:

Despite the provisions of this acceptable solution, some smoke may spread into a shared *exitway* due to a *fire* in a *suite* or *household unit*, if only because the entrance door will be open while the occupants escape. Where the conditions of Paragraph 6.9.6 a) to e) apply, the risk to escaping occupants from smoke in *exitways* is relatively low.

6.9.7 In vertical *safe paths* natural ventilation shall be achieved using roof-mounted ventilators with a nominal exhaust capacity of no less than 0.7 m³/sec, or vents at the top of the *safe path* providing a total free vent area of no less than 1.5 m². Make-up air shall be provided using vents or grilles providing a total free vent area of no less than 0.7 m², and located no higher than 1.0 m above the lowest floor level. Where vents are not permanently open, they shall be opened automatically when activated by a smoke detection system (complying with F7/AS1) in the *safe paths*.

6.9.8 In horizontal *safe paths*, or in each section of the *safe path* when subdivided by *smoke control doors*, natural ventilation shall be achieved using roof-mounted ventilators with a nominal exhaust capacity of no less than 0.5 m³/sec, or high level vents providing a total free vent area of no less than 1.0 m². Make-up air shall be provided using vents or grilles providing a total free vent area of no less than 0.5 m², and located no higher than 1.0 m above the *safe path* floor level. Where vents are not permanently open, they shall be opened automatically when activated by a smoke detection system (complying with F7/AS1) in the *safe paths*.

COMMENT:

1. Permanent ventilation in *external walls* should be by specific design taking into account adverse wind effects and tenability in the *exitway*.
2. Where the shared *exitway* is not on the top floor of the *building*, alternatives to natural ventilation such as pressurisation of *exitways* should be considered.

3. Exhaust capacities for ventilators are normally given by the manufacturer and are dependent on wind speed. A capacity based on a design wind speed that is exceeded 95% of the time is considered acceptable.
4. The ventilation system should not develop a negative pressure more than 0.5 Pa below atmospheric pressure otherwise the ratings of *fire doors* will be compromised. If mechanical ventilation is used the preferred position for the fan is at the bottom of the shaft to generate positive pressure.

6.9.9 The required vent area shall be available when vent closures are in the fully open position.

6.9.10 An enclosed *stairway* need not be naturally ventilated where all the horizontal *exitways* it serves are naturally ventilated.

Vertical safe path smoke control

6.9.11 Vertical *safe paths* which exceed a height of 25 m, shall be divided by *smoke separations* and *smoke control doors* at the landing nearest mid-height (see Figure 6.1). This requirement does not apply to pressurised *exitways*, or where the *building* is sprinklered.

6.10 Purpose Group IA**Support activities**

6.10.1 Except as provided for waste storage and car parking in Paragraphs 6.10.2 to 6.10.6, *purpose group IA* activities providing direct support to a primary activity of another *purpose group* may be included with the other *purpose group* and do not require *fire* or *smoke separation*. The *fire safety precautions* required by Table 4.1 for the primary *purpose groups* shall also apply throughout the IA spaces. Where an IA space is required to be a separate *firecell*, it shall have *fire separations* with a *FRR* of 30/30/30, or that applying to the highest rated adjoining space, whichever is the greater.

COMMENT:

Examples of spaces which provide support functions and are occupied intermittently include corridors, tea rooms, ironing rooms, laundries, waiting rooms, kitchens in assembly uses etc.

Figure 6.1: Vertical Safe Path Smoke Control
Paragraphs 3.17.12 a) and 6.9.11

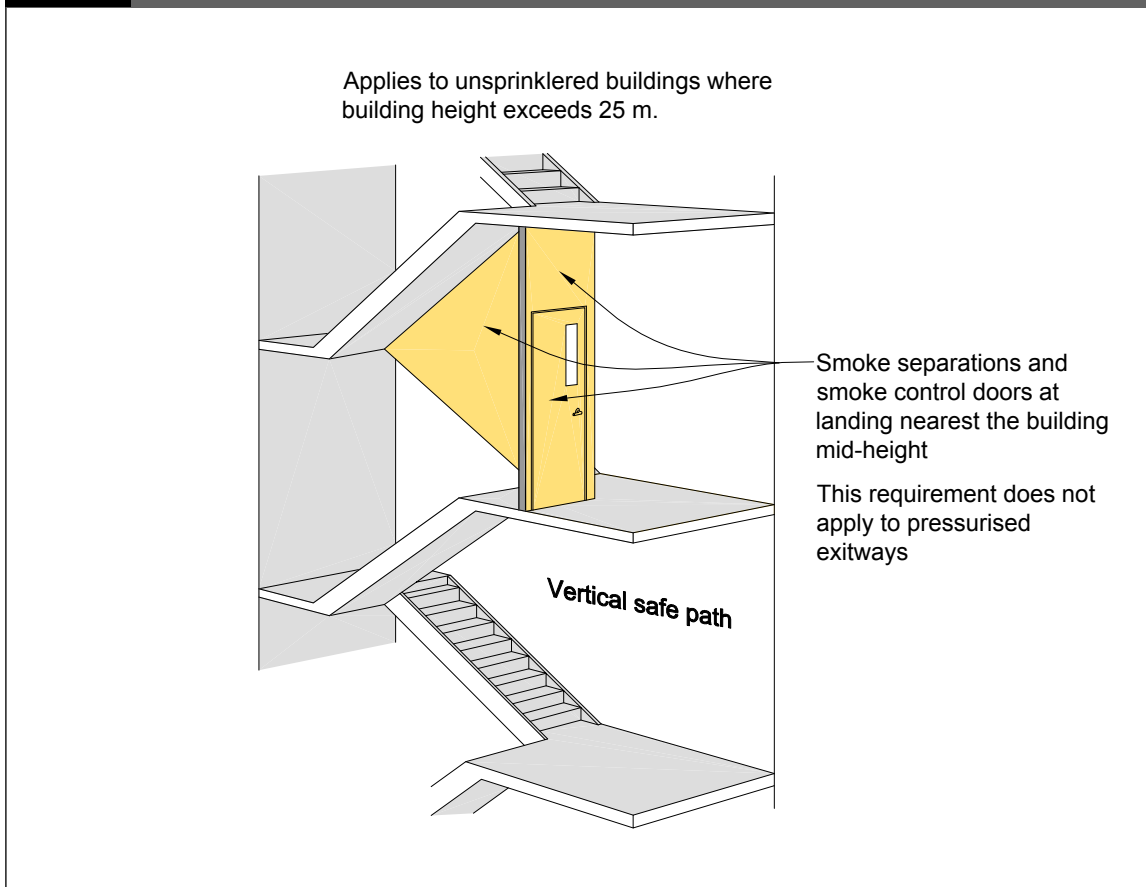

Solid waste storage

6.10.2 Enclosed solid waste storage areas within any *firecell* shall themselves be a separate *firecell* separated from adjacent *firecells* by *fire separations* having a *FRR* of no less than 60/60/60 (see Paragraph 6.16.5 for waste chutes).

Amend 5
Oct 2005

Car parking

6.10.3 Car parking spaces within a *building* (see Figure 6.2) shall be separate *firecells*. Within the car park *firecell*, all floors (including *intermediate floors*) and their supporting structures shall be *fire rated*.

COMMENT:

A car park may be one *firecell* extending from below the level of the *final exit* to any number of floors above, with each floor (except the lowest) being an *intermediate floor*.

Figure 6.2: Car Parking
Paragraph 6.10.3

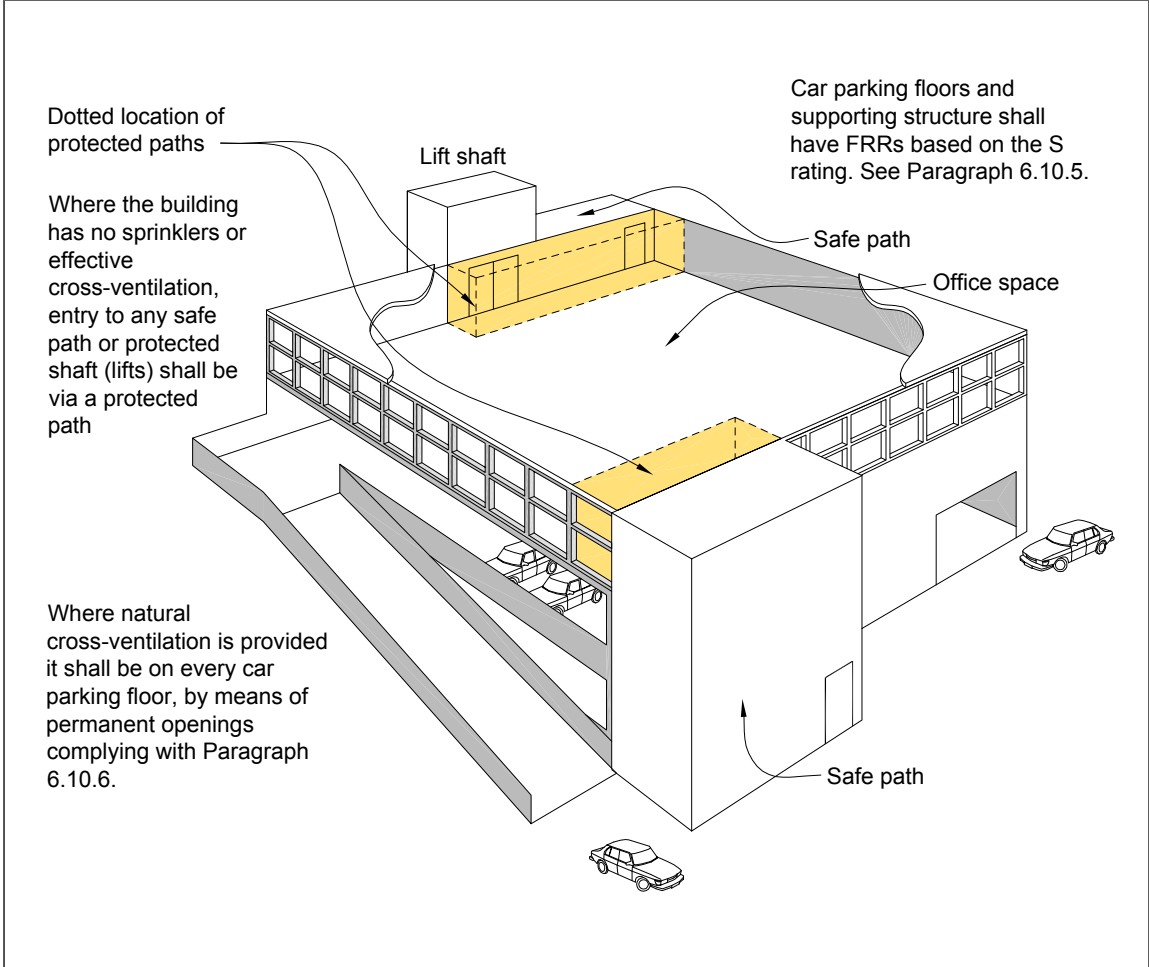

6.10.4 Where the car park *firecell* is neither sprinklered nor provided with openings which allow effective cross-ventilation (see Paragraph 6.10.6):

- a) Entry to any *safe path*, or *protected shaft* containing lifts, shall be preceded by a *protected path*, and
- b) Smoke control by specific *fire* engineering design shall apply, and
- c) Where parking is provided for more than 10 cars, a Type 3 alarm (see Appendix A Paragraph A2.1) shall be installed.

COMMENT:
The large volumes of smoke and toxic products produced by a car *fire* constitute the principal hazard to life in a car park *firecell*. Car park burn tests have demonstrated that either the provision of effective cross-ventilation or the operation of sprinklers will significantly reduce this hazard.

6.10.5 *FRRs for building elements in car parking spaces shall be based on the S rating as derived from the formula:*

$$S = Ct_e$$

Where:

t_e (equivalent time of fire exposure in minutes) is derived from Table 5.1, and C is a variable having the following values:

For fire separations between firecells:

- C = 1.0 if unsprinklered, or
- = 0.5 if sprinklered.

For floors and supporting elements within the car park firecell:

- C = 0.5 if unsprinklered, or
- = 0.25 if sprinklered.

6.10.6 Where smoke control in a car parking firecell is by natural cross-ventilation, perimeter walls on each floor shall have permanent openings to the outside environment. The size of those openings shall be:

- a) No less than 50% of the wall area in each of any two opposing walls, or
- b) No less than 50% of the total perimeter wall area with those openings distributed uniformly along no less than half the total perimeter wall length.

6.11 Purpose Group ID

6.11.1 Firecells in which ID is the primary purpose group, shall meet the same fire safety precautions as specified in Table 4.1 for purpose group WM, and shall be separated from adjacent firecells by fire separations having a FRR of no less than 60/60/60.

6.11.2 Where purpose group ID provides only support functions to another purpose group, and meets the requirements of Paragraphs 5.6.7 and 5.6.8 the ID function need not be individually fire separated and may be included with the primary purpose group.

Plant, boiler and incinerator rooms

6.11.3 Within a building any space (see Figure 6.3) containing an incinerator, plant, boiler or machinery which uses solid fuel, gas or petroleum products as the energy source, (but excluding space heating appliances), shall be a separate firecell with a rating of F60, or F90 if the adjacent firecells contain SC and SD purpose groups, and shall have:

- a) At least one wall an external wall,
- b) Access direct from the outside. If internal access is also provided, it shall be through a protected path equipped with a heat detector which activates a warning alarm in frequently occupied spaces within the building, and
- c) Its floor level no lower than the ground level outside the external wall if gas is the energy source.

6.11.4 Where plant is contained in a building which is solely for the purposes of containing such plant and that building is separated by 3.0 m or more from any adjacent building, only Paragraph 6.11.3 c) shall apply.

6.12 Firecell Construction

6.12.1 Each of the building elements enclosing a firecell may have different FRRs depending on the characteristics of the firecell, the reason for the FRR, and the purpose groups contained on either side of any fire separation. A zero rating may apply to some walls and most roofs.

6.12.2 Except as provided for in Paragraph 6.14.1 each floor in a multi-storey building shall be a fire separation.

6.12.3 Fire and smoke separations shall have no openings other than:

- a) For closures such as doorsets, and for penetrations, satisfying the provisions of Paragraphs 6.17 and 6.19, and
- b) Glazing permitted by Paragraph 5.8.

Amend 4
Oct 2005

Amend 5
Oct 2005

Amend 7
Nov 2008

Figure 6.3: Plant, Boiler and Incinerator Rooms
Paragraph 6.11.3

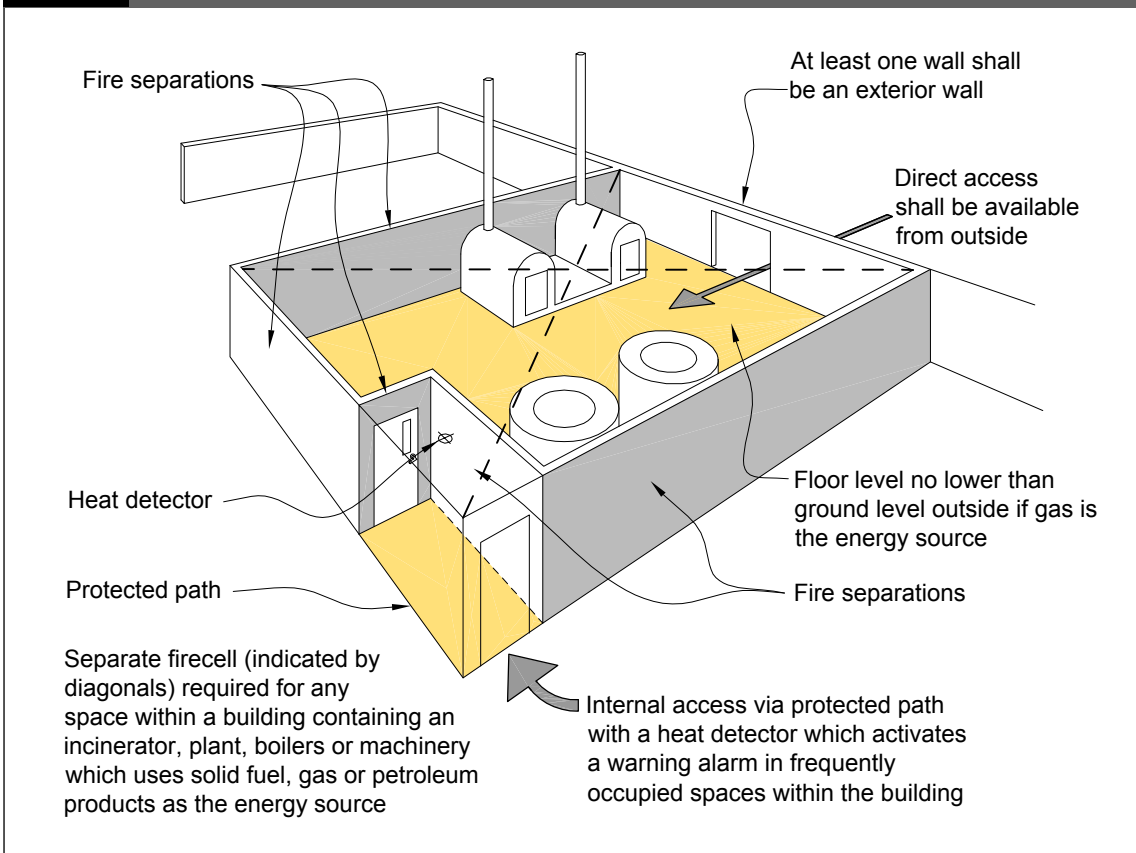

6.12.4 *Firecell* and *smokecell* effectiveness shall be maintained by ensuring continuity of *fire* and *smoke separations* at separation junctions, and around joints where *doorsets*, *protected shafts* and *penetrations* occur.

Junctions of fire separations

6.12.5 Where *fire separations* meet other *fire separations* or *fire rated parts of external walls*, they shall be bonded together or have the junction *fire stopped* over its full length (see Figure 6.4).

6.12.6 Where one *fire separation* is a wall, and the other a floor of timber *construction*, the wall/floor junction shall be *constructed* with the *FRR* required for the higher rated element.

Junctions with roof

6.12.7 Vertical *fire separations* and *external walls* shall either:

- Terminate as close as possible to the external roof cladding and *primary elements* providing roof support, with any gaps fully *fire stopped* (see Figure 6.4), or
- Extend not less than 450 mm above the roof to form a parapet (see also Paragraph 7.8.1).

COMMENT:

Roof space areas are restricted by Paragraph 6.18.7 to 6.18.10.

Figure 6.4: Junctions of Fire Separations
 Paragraphs 6.12.5, 6.12.7 a), 6.14.1, 6.14.2 and 6.18.8

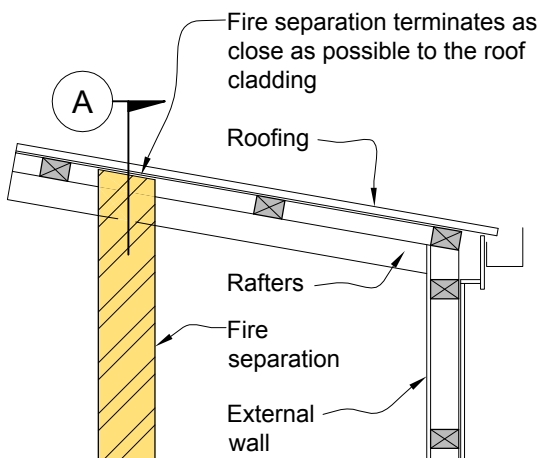

Section (a)

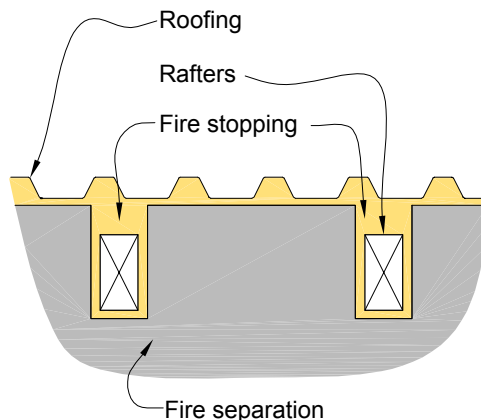

Section A - A (b)

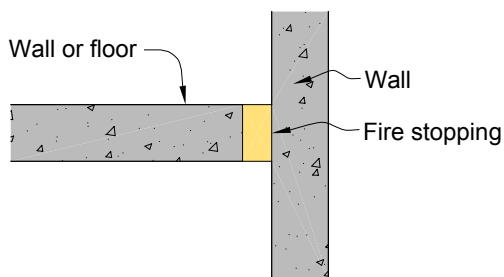

Plan or section (c)

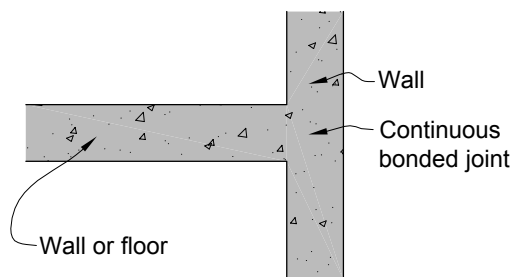

Plan or section (d)

See Figure 6.11 for curtain walls

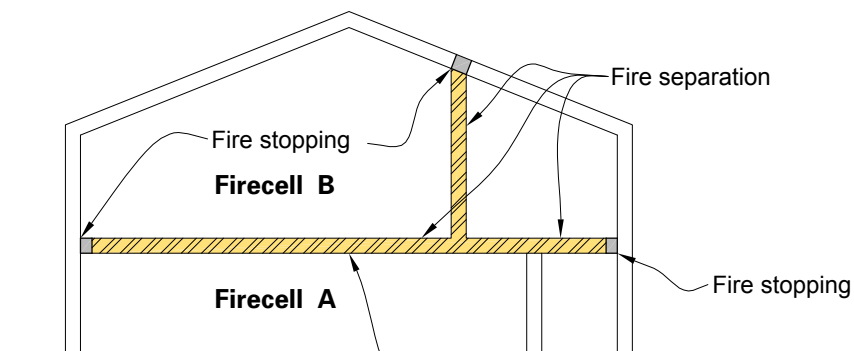

Section (e)

FRR of floor to be that rating applicable to the firecell below the floor, i.e. Firecell A

Ceiling space firecells

6.12.8 Large roof or ceiling spaces may be constructed as separate *firecells* above more than one occupied *firecell* provided that the ceiling is a *fire separation* rated from below. In this situation vertical *fire separations* in the *firecell* below need terminate only at the ceiling.

COMMENT:

Roof and ceiling space areas in *purpose groups* SA and SR are restricted by Paragraphs 6.18.7 to 6.18.10.

These lengths may be increased by 50% where the corridor and adjacent *firecells* are sprinklered.

COMMENT:

1. The *smoke control doors* must swing both ways where required by Paragraph 3.17.3.
2. *Hold-open devices* are required by Paragraph 3.17.9 to allow the doors to remain open during normal use of the *building*, but close automatically in the event of a *fire*.

Sealing of gaps

6.12.9 To avoid the passage of smoke, gaps greater than 0.5 mm wide shall be sealed with mastics, sealants or other materials resistant to the effects of hot smoke when they are located:

- a) In *smoke separations*, and between *smoke* and *fire separations*,
- b) Around glazing in *smoke separations*,
- c) Between *fire* or *smoke separations* and unrated parts of *external walls*, or
- d) Around *penetrations* (see Paragraph 6.17 for *fire stopping* requirements).

COMMENT:

Different requirements apply to *fire* and *smoke control doors*. Refer Paragraphs 6.19.1 to 6.19.8.

6.13 Long Corridor Subdivision

6.13.1 Long unpressurised corridors shall be subdivided by *smoke separations* and *smoke control doors* (see Figure 6.5) which shall be evenly spaced along the corridor and no further apart than:

- a) 40 m within *open paths* and *protected paths*, or
- b) 80 m within *safe paths*.

Figure 6.5: Long Corridor Subdivision
Paragraphs 3.17.12 b) and 6.13.1

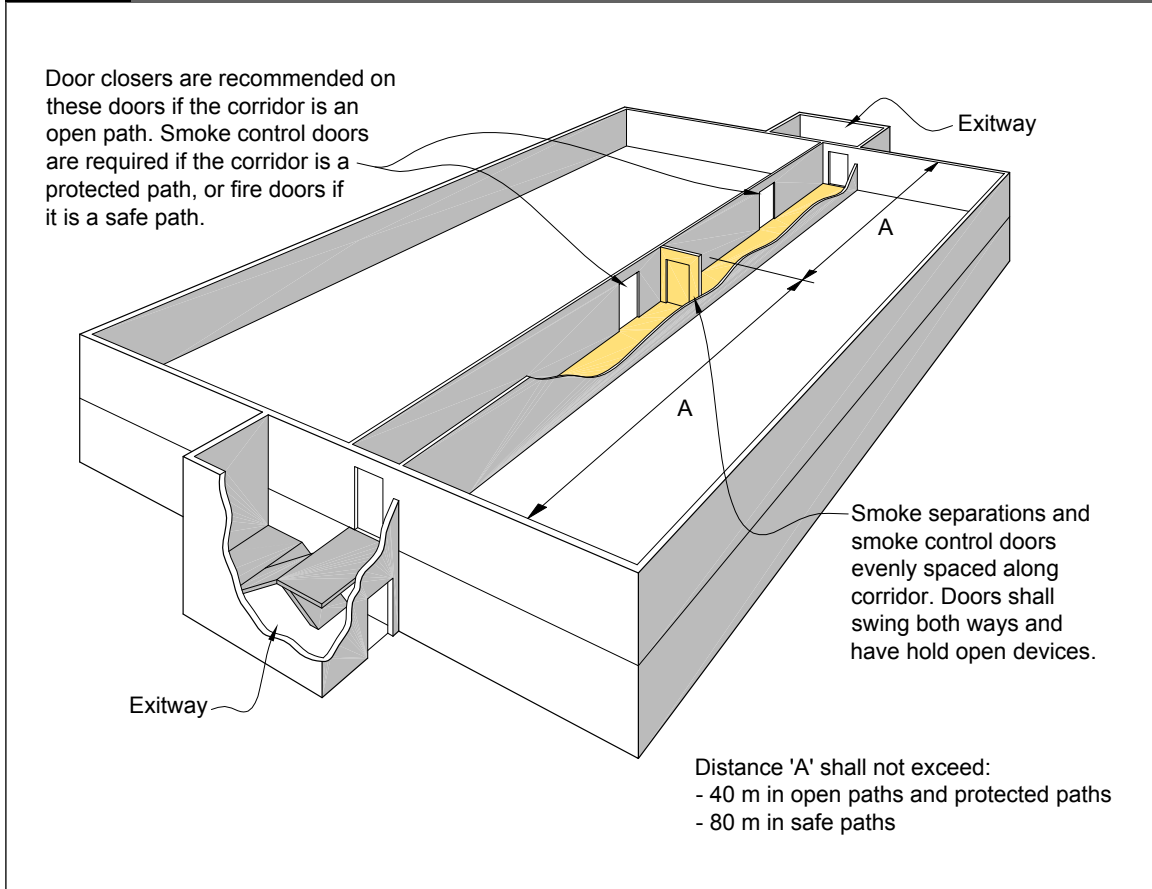

6.14 Floors

6.14.1 Floors in *buildings* shall be *fire separations* (see Figure 6.4) except where any of the following conditions are satisfied:

- a) The floor is an *intermediate floor* within a *firecell* (see Paragraph 6.14.3 for *FRR* requirement).
- b) The floor is the lowest floor above an unoccupied sub-floor space, and complies with Paragraph 6.15.1.

6.14.2 Floors need to be rated only on the underside (see Figure 6.4). The *FRR* of a floor shall be that rating applicable to the *firecell* directly below the floor.

COMMENT:

The main threat to a floor is a *fire* beneath that floor.

Intermediate floors

6.14.3 *Intermediate floors* and their supporting *primary elements* within the *firecell* (see Figure 6.6) shall have *FRRs* of no less than 15/15/15 except where the area under the *intermediate floor* is enclosed the *FRR* shall be 30/30/30. The provision does not apply to *purpose group* SH or to *household units* in *purpose group* SR, and *suites* in *purpose group* SA.

COMMENT:

The provisions for shorter *open path* length on *intermediate floors*, and for alarms and smoke control, allow occupants *adequate* time to escape to a *safe place*. On this basis there is no need to rate *intermediate floors* higher than 15/15/15 where the area under the *intermediate floor* is not enclosed. See Paragraphs 6.21.3 to 6.21.6 for other requirements of *intermediate floors*.

Amend 4
Oct 2005

Amend 4
Oct 2005

Figure 6.6: Intermediate Floors
Paragraph 6.14.3

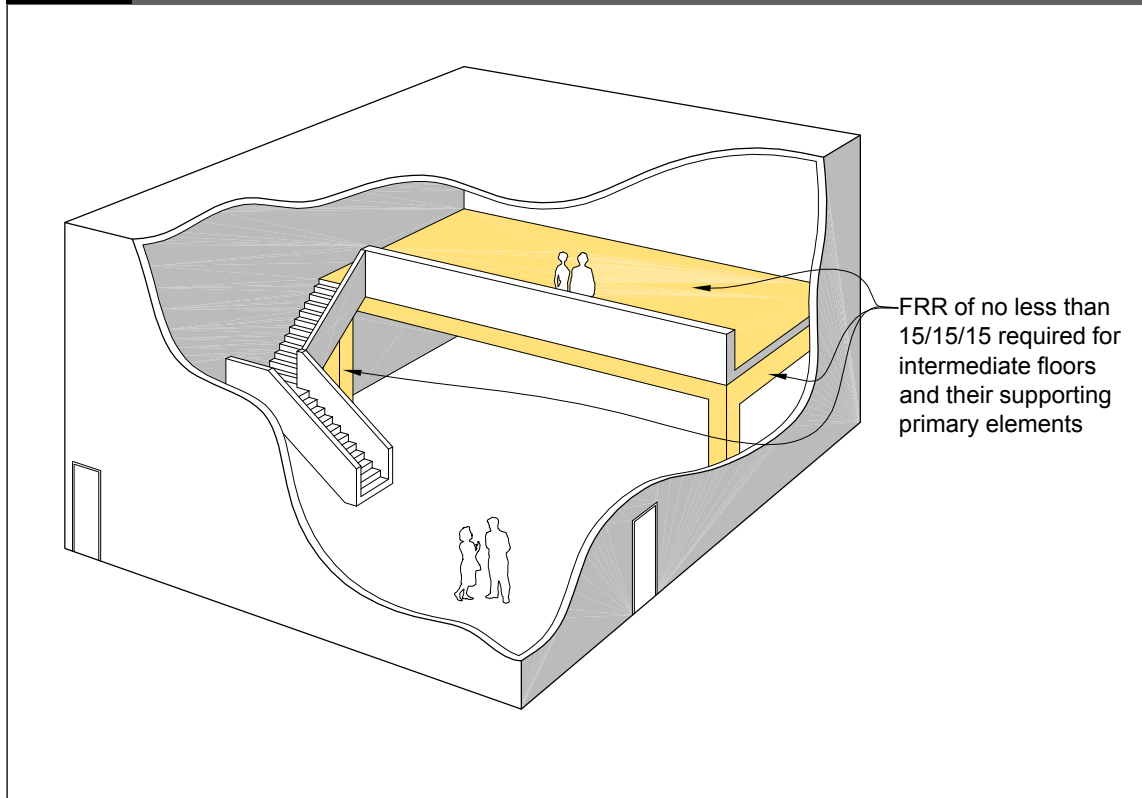

Basement floors

6.14.4 *Basement firecells* shall be separated from one another, and from the lowest *firecell* above ground level, by *fire separations* having a *FRR* of no less than 60/60/60. This does not apply to *purpose group SH* or within *household units* of *purpose group SR*.

6.15 Subfloor Spaces

6.15.1 In *buildings* with an unoccupied subfloor space between the ground and lowest floor (see Figure 6.7), the *FRR* of that floor shall be based on no less than half the *firecell rating* from Table 4.1, except that no *FRR* is required when all the following conditions are satisfied:

- Vertical *fire separations* and *external walls* extend down to ground level and enclose the space.
- Access is available only for intermittent servicing of plumbing, drainage or other static services.
- The space is not used for storage, and does not contain any installation such as machinery or heating appliances, which could create a *fire hazard*, except when *fire* separated from the rest of the subfloor space.

Figure 6.7: Subfloor Spaces
Paragraph 6.15.1

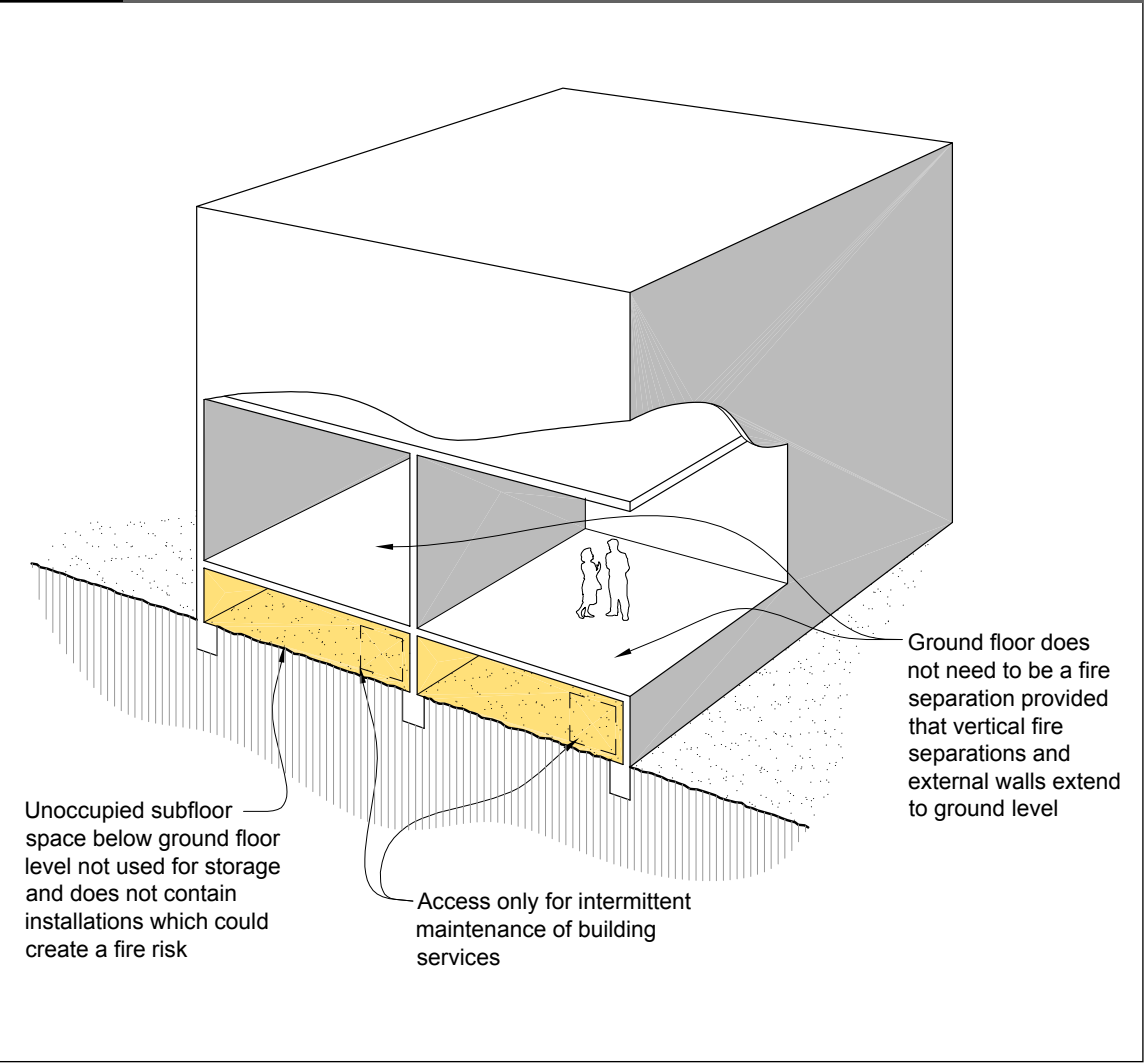

6.16 Protected Shafts

Lifts, conveyors and services

6.16.1 Lifts, conveyors and services which pass from one *firecell* to another shall be enclosed within *protected shafts*. (Refer to Paragraph 6.19.13 for *doorsets* in lifts.)

COMMENT:

Paragraph 3.12.3 describes the requirements for the installation of a passenger lift in a vertical *safe path* containing a *stairway*. In those circumstances the vertical *safe path* must be a single *firecell*.

Fire separation

6.16.2 Every *protected shaft* shall be a separate *firecell* within the *firecell* or *firecells* in which it is located (see Figure 6.8). The shaft walls between each floor shall have a *FRR* based on no less than the highest *F rating* of any *firecell* abutting the *protected shaft* at that level, or 30/30/30, whichever is the greater.

COMMENT:

The *FRR* of the shaft wall shall apply to both sides equally, except in the case of lift landing doors (see 6.19.13).

Amend 4
Oct 2005

Amend 4
Oct 2005

Figure 6.8: Protected Shafts
Paragraphs 6.16.2, 6.16.4 and 6.16.5 e)

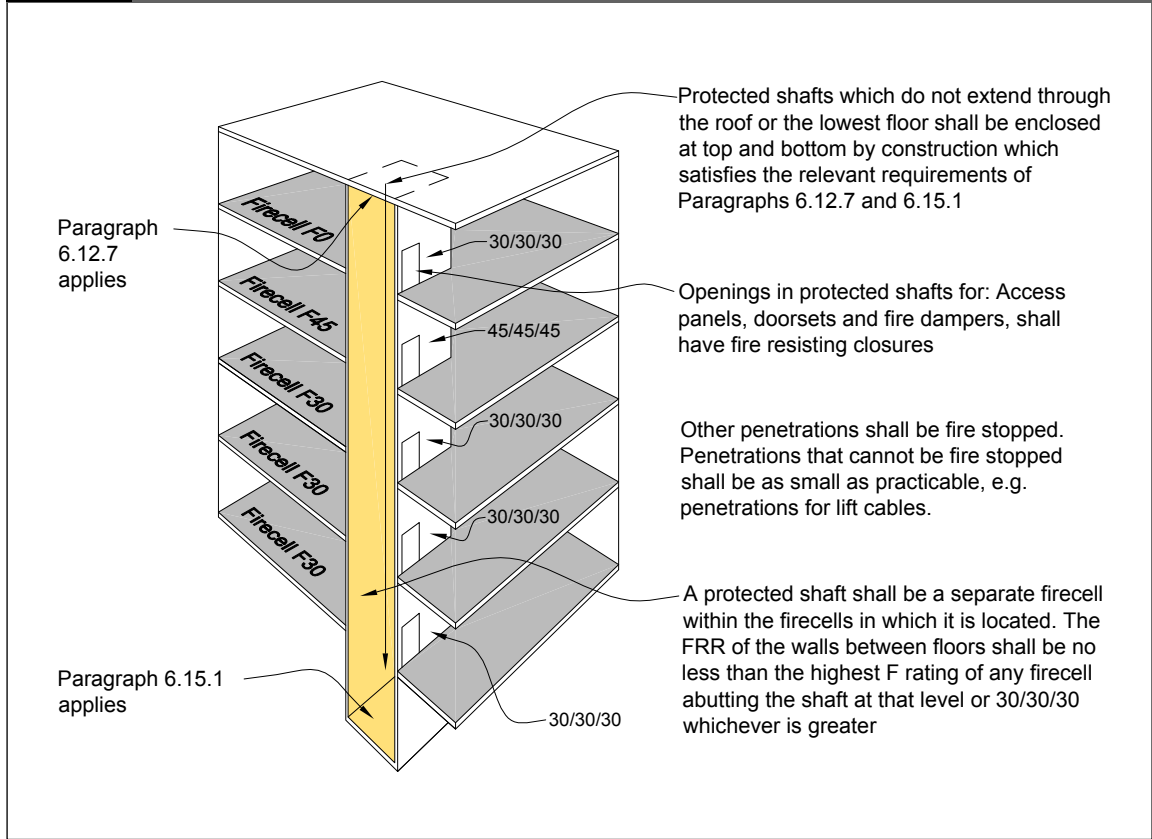

Amend 4
Oct 2005

6.16.3 Protected shafts which do not extend through the roof or lowest floor shall be enclosed at top and bottom by construction which satisfies the relevant requirements of Paragraphs 6.12.7 for fire stopping, and 6.15.1 for enclosure (see Figure 6.8).

Openings in protected shafts

Amend 4
Oct 2005

6.16.4 There shall be no openings in protected shafts except for:

- a) Access panels complying with Paragraph 6.19.12 for fire resisting closures,
- b) Doorsets providing access to lifts and complying with Paragraph 6.19.13 for smoke control,

- c) Openings for lift ropes passing into a lift motor room, which shall be as small as practicable,
- d) Fire dampers serving a ventilation duct and complying with Paragraph 6.19.14 for fire resisting closures,
- e) The passage of penetrations which satisfy Paragraph 6.17 for fire stopping (see Figure 6.8), or
- f) Fittings which have an approved fire rating providing a FRR of no less than that required for the fire separation within which they are installed.

COMMENT:

While not strictly an opening, a cabinet to house, say, a hosereel, and let into a wall would not reduce the FRR of the wall provided the cabinet has an approved FRR of no less than that of the wall.

Solid waste and linen chutes

Amend 4
Oct 2005

6.16.5 Solid waste and linen chutes which pass from one *firecell* to another shall be *protected shafts* or contained within a *protected shaft*. For *purpose groups* SA and SR, if the *building* is not sprinklered, each chute shall be equipped with automatic sprinkler heads connected to any water supply pipe of 19 mm diameter or greater. Those sprinklers shall be installed at the top of each chute and in the space into which the chute discharges. The minimum residual pressure in the water supply pipe shall be 35 kPa with two sprinkler heads operating.

COMMENT:

The minimum residual pressure requirement for any operating sprinkler is to ensure sufficient flow rate and area coverage to control a *fire*.

Amend 4
Oct 2005

6.16.6 Solid waste and linen chutes shall have no inlet or discharge openings within an *exitway*.

COMMENT:

See Paragraph 6.10.2 for requirements of solid waste storage areas.

Sprinklers in protected shafts

Amend 4
Oct 2005

6.16.7 Where sprinklers are installed in vertical *protected shafts* which contain *building services*, in order to ensure water *penetration* to all points of the shaft, coverage shall comply with NZS 4541 or NZS 4515, and sprinklers shall be located to deliver water in sufficient quantities to extinguish a *fire* in any location within the shaft.

6.17 Fire Stopping

Introduction

6.17.1 The continuity and effectiveness of *fire separations* shall be maintained around *penetrations*, and in gaps between or within *building elements*, by the use of *fire stops*.

Fire stops

6.17.2 *Fire stops* shall have a *FRR* of no less than that required for the *fire separation* within which they are installed, and shall be tested in accordance with Paragraph C7.1 of Appendix C.

6.17.3 *Fire stops* and methods of installation shall be identical with those of the prototype used in tests to establish their *FRR*.

6.17.4 The material selected shall be approved as appropriate for the type and size of the gap or *penetration*, and for type of material and *construction* used in the *fire separation*.

COMMENT:

There are many types of *fire stops* (e.g. mastics, collars, pillows etc.), each designed to suit specific situations. Whether a *fire stop* is appropriate for a particular application may be judged on evidence that it passed the test criteria when installed as proposed.

Installation

6.17.5 Hollow construction: Where used around *penetrations* passing through hollow *construction*, the *fire stop* shall protect the *penetration* over its full length within the *fire separation*. It shall also be restrained from moving or parting from the surfaces of both the *penetration* and *fire separation*.

Service outlets

6.17.6 Where service outlets such as electrical sockets and switches emerge from a hollow *fire separation*, the cavity in the separation shall be suitably protected with an approved *fire stop* material for the full size of the opening (see Figure 6.9).

Figure 6.9: Service Outlets
Paragraph 6.17.6

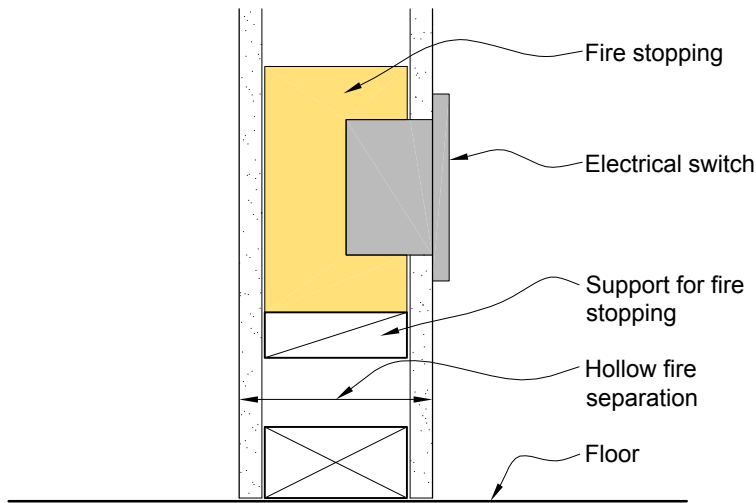

Penetrations to be supported

6.17.7 To avoid failure of the seal provided by the *fire stop*, *penetrations* shall be supported to resist movement or collapse during *fire*. The support system shall not prevent normal expansion or contraction of the *penetration*. See also Paragraph 6.12.9.

2. To provide *building* occupants, particularly sleeping *purpose groups*, with early warning in the event of *fire*, reliance is often placed on the provision of smoke detection and alarm systems. However, where the smoke detectors are located only in the *occupied spaces*, smoke and *fire* can travel unobserved in upper *concealed spaces* that have not been *fire* or smoke separated. See Paragraphs 6.18.4 and 6.18.5 for subdivision requirements of *concealed spaces*.

6.18 Concealed Spaces

6.18.1 The spread of *fire* in *concealed spaces* and cavities shall be avoided by ensuring that extensive voids do not pass from one *firecell* to another, and by blocking-off smaller voids with *cavity barriers*, or where appropriate, by using *fire stops*.

COMMENT:

1. Throughout this acceptable solution one method of controlling *fire* and smoke spread is by enclosing spaces with *fire* and *smoke separations*. Where *fire separations* are internal walls, it is essential that those walls enclose any upper *concealed space* by extending beyond the ceiling to the floor or roof above.

Concealed spaces within firecells

6.18.2 An upper *concealed space* may be used as an air-handling plenum (see Figure 6.10) if all the following requirements are satisfied:

- a) The upper *concealed space* shall not extend into another *firecell* except as permitted in Paragraph 6.18.3.
- b) The ceiling and its supports and surfaces within the *concealed space* are *non-combustible*.
- c) Electrical wiring is supported clear of the ceiling members and other equipment.

- d) The *SFI* and *SDI* of any material used, such as pipe insulation or acoustic insulation comply with the requirements of Table 6.2.
- e) Where the air handling plenum is used as an air supply path, an automatic *fire* detection and alarm system is fitted throughout the *firecell*, with detectors in all return air ducts.

- f) Where the air handling plenum is used as an air supply path, detector activation causes the ventilation system to switch from circulation to extract as required by Paragraph 6.23.1.

COMMENT:

Items e) and f) do not apply when the air handling plenum is used as an air exhaust path with a separate ducted air supply to the *firecell*.

Figure 6.10: Concealed Spaces within Firecells
Paragraph 6.18.2

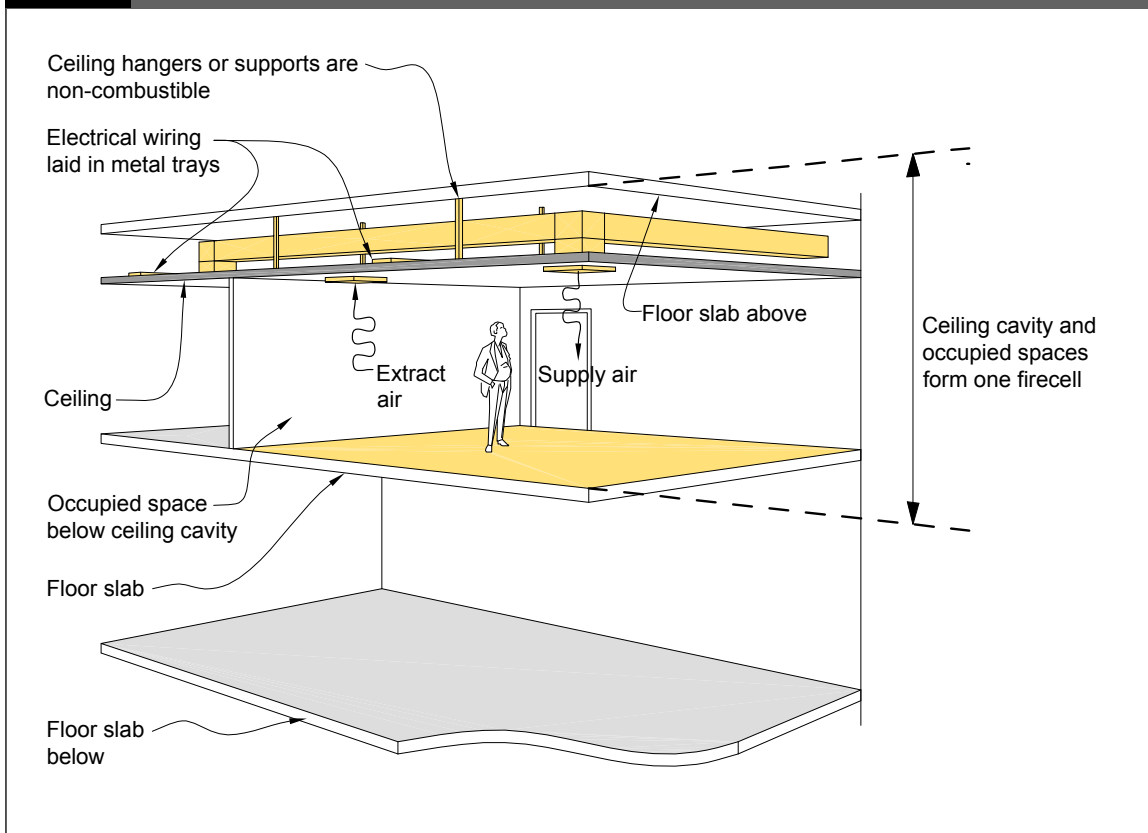

Notes:

1. If the plenum is used as an air supply path see Paragraphs 6.18.2 (e) and (f) for automatic *fire* detection and alarm requirements.
2. If the *firecell* is required by Table 4.1 to have smoke control in the air handling system (*FSP* Type 9), see Appendix A, Paragraph A 2.1.1 for necessary *fire* detection and alarm systems.

6.18.3 Where the *concealed space* is connected to another *concealed space* in an adjacent *firecell*, any openings in the *fire separation* between the *firecells* shall be fitted with closures as specified in Paragraph 6.19.

Cavity barriers in walls and floors

6.18.4 Any *concealed space* which may be a path for *fire spread* within internal walls or floors which are *fire separations*, or within *external walls*, shall have *cavity barriers*, or be

fire stopped, at all common junctions (see Figures 6.11 and 6.12).

COMMENT:

It is essential in multi-storey *buildings* to avoid rapid vertical *fire spread* between floors. Paragraph 7.9.14 deals with the particular requirement for *external walls*, where "curtain wall" type *construction* may create extensive cavities.

Figure 6.11: Curtain Wall
Paragraphs 6.18.4, 7.1.1 a), 7.9.14 and Figure 6.4

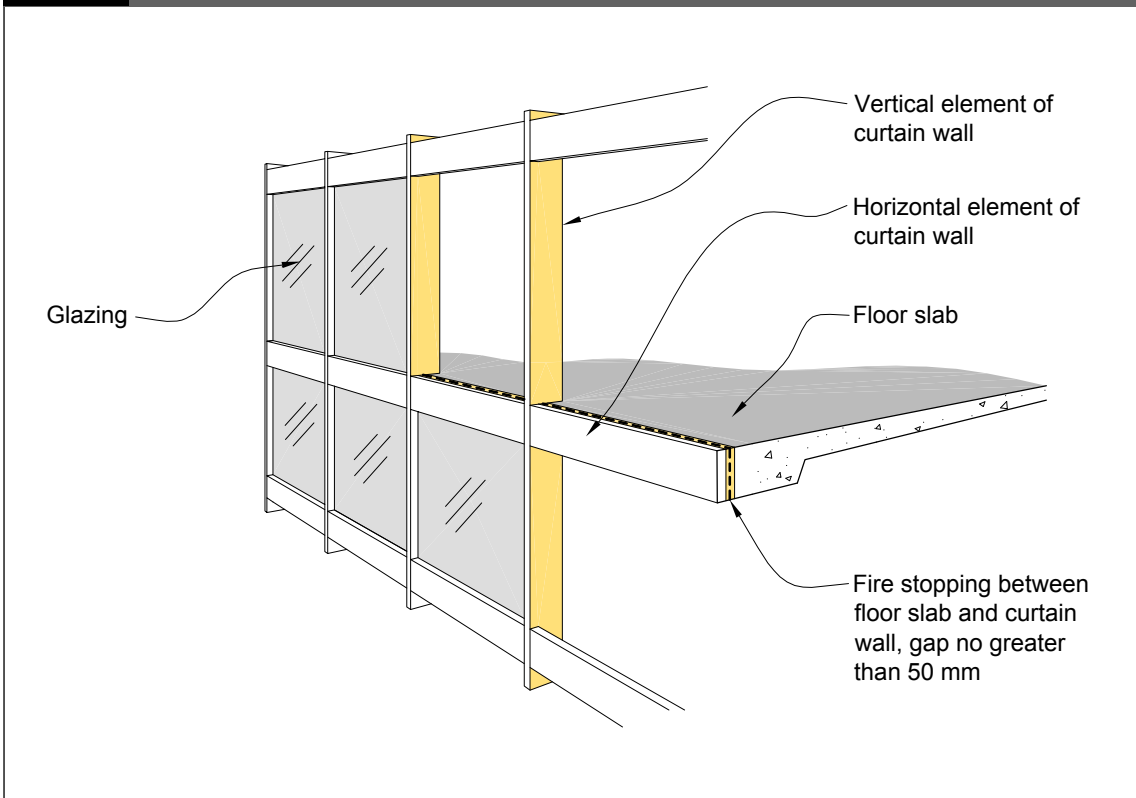

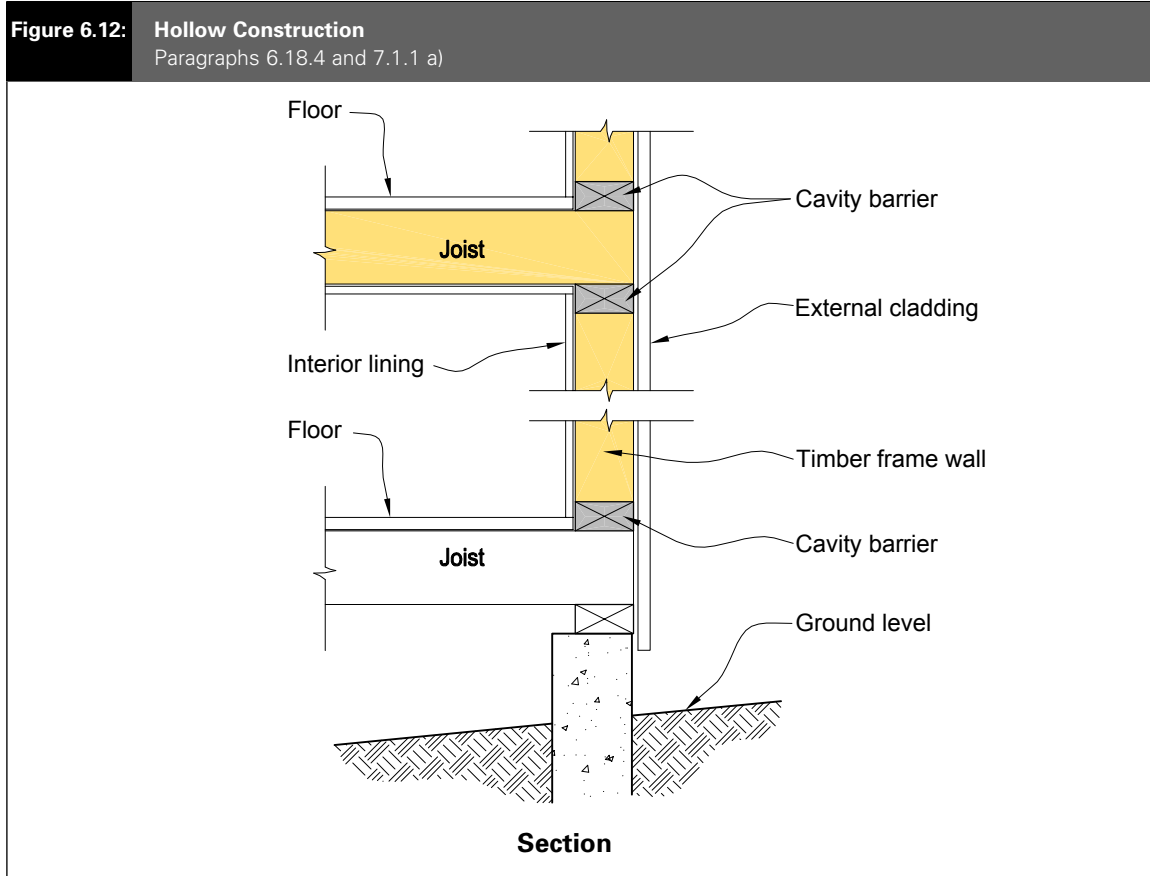

Exceptions

6.18.5 *Cavity barriers* are not required in the following circumstances:

- a) Below a floor next to the ground if the *concealed space* is:
 - i) less than 1.0 m in height, or
 - ii) not normally accessed and has no openings through which litter can accumulate, or
- b) Where the *concealed space* results from the over-cladding of an existing *external wall* or roof, provided that the existing cladding is *non-combustible*, or
- c) In a wall or roof panel system encapsulated with a *flame barrier* complying with Appendix C, Paragraph C10.1.

COMMENT:

Care must be taken to ensure that the *integrity of flame barriers* around *penetrations* and openings is maintained.

Cavity barrier construction

6.18.6 *Cavity barriers* shall:

- a) Not reduce the *FRR* required for the element within which it is installed,
- b) Where practical be tightly fitted and mechanically fixed to rigid *construction*, but where this is not possible, gaps shall be *fire stopped*,
- c) Be fixed in a way which avoids impairment of their *fire separation* function as a result of:
 - i) *building* movement due to subsidence, shrinkage or thermal change, or

- ii) collapse or failure of their components or fixings, or of abutting materials and any penetrations during a fire.

Restriction of roof and ceiling space areas in unsprinklered firecells

6.18.7 Within unsprinklered *firecells* in *purpose groups* SA and SR, roof space and ceiling space areas shall be subdivided by *fire separations* to prevent the hidden spread of fire. Any space between ceilings and roofs or floors above shall not exceed 400 m² in area, measured at ceiling level, and 30 m in length or width. This provision does not apply where the space is a separate *firecell*.

6.18.8 The *fire separations* used for subdivision shall have a *FRR* of no less than -/30/30 and extend from the ceiling to the underside of the external roof cladding or floor above. Any gaps shall be *fire stopped* (see Paragraph 6.12.7 and Figure 6.4).

6.18.9 Where openings in the *fire separations* are required for service access or any other reason, they shall be fitted with *fire resisting closures*. Gaps around service penetrations shall be *fire stopped*.

Sprinklered firecells

6.18.10 For sprinklered *firecells* in all *purpose groups*, the provision of *fire separations* and sprinklers in *concealed spaces* between ceilings and roofs or floors above, shall comply with NZS 4541 or NZS 4515 as amended by Appendix D.

COMMENT:

NZS 4541 Clause 207 permits exceptions to sprinkler installation in concealed ceiling and floor spaces in specific circumstances. One requirement is for smaller subdivision than permitted by Paragraph 6.18.7 for unsprinklered *firecells*.

Amend 8
Sep 2010

6.19 Closures in Fire and Smoke Separations

Introduction

6.19.1 Where activities within a *building* require openings in *fire* or *smoke separations* (e.g. for the passage of people, goods or for light), closures to those openings shall have the *fire* resistance and smoke control performance appropriate to their location as required by Table 6.1.

6.19.2 *Doorsets* which are required to be:

- a) *Fire doors*, shall comply with Paragraph C8.1 of Appendix C.
- b) *Smoke control doors* shall, except as required by Paragraph 6.19.4, comply with Paragraph C8.1 of Appendix C. Smoke seals shall be fitted at the head and all vertical edges in the gaps between the door leaf or leaves and the frame, and between leaves in multi-leaf *doorsets*.

COMMENT:

Smoke seals may be of the brush type and need not incorporate intumescent material. However, intumescent seals may be required if the door is also a *fire* door.

- c) *Fire doors* with smoke control capability shall comply with both a) and b).

6.19.3 Table 6.1 summarises the requirements for closures.

6.19.4 *Doorsets* installed in *fire separations* between *firecells* and vertical *safe paths* or *protected shafts* shall have smoke seals on all edges, except that smoke seals may be omitted:

- a) At the sill of *doorsets* on the ground floor in a *building* of any height,
- b) At the sill of *doorsets* at each level in two or three floor *buildings*, and
- c) Entirely from *doorsets* at any level when a *safe path* is pressurised (see Note 2 of Table 6.1), and
- d) When permitted for lifts by Table 6.1, Note 3.

COMMENT:

In multi-floor *buildings* thermal gradients exist in internal shafts resulting from atmospheric conditions outside the *building*. There will be a neutral pressure point somewhere about the mid-height, above which there may be air flow from the shaft into the floors. *Doorsets* opening into these shafts should not have large gaps at the sill which would otherwise be acceptable in *doorsets* in *escape routes*. This effect is negligible in low *buildings*.

COMMENT:

1. See Paragraph 6.3.1 for determining when the proscenium wall should be *fire* rated. See Paragraph 6.3.2 a) and Table 4.1 for determining when sprinklers are required.
2. Uniform Building Code Standard 4-1 is an acceptable standard for the design and *construction* of a Proscenium Fire Safety Curtain.

Fire door and smoke control door installation

6.19.5 *Fire doors* and *smoke control doors* shall be installed in accordance with Paragraph 3.17.

Doorset markings

6.19.6 *Doorsets* shall be clearly marked to show their *FRR* and where required to show their smoke stopping capability.

COMMENT:

A door marked -/60/30 Sm would be a *fire door* with an *integrity* of 60 minutes, and an *insulation* of 30 minutes, which may be used as a *smoke control door*. A door marked -/- Sm would be a *smoke control door* only, with no *FRR*.

Amends
7 and 9

6.19.7 Markings and labelling shall in all other respects comply with NZS 4520.

Glazing in doors

6.19.8 Glazing in *fire doors* and *smoke control doors* shall comply with Paragraphs 5.8.10 and 5.8.11.

Theatre proscenium walls

6.19.9 The *fire resisting closure* (see Figure 6.13) to the stage opening in a *fire* rated proscenium wall shall be an approved *fire* curtain. Where the auditorium, stage area, and all spaces used for support activities are sprinklered, sprinklers, or drenchers complying with NZS 4541 Clause 514.1, shall be installed above the proscenium opening and be located so that both sides of the *fire* curtain are kept wet in the event of *fire*.

Figure 6.13: Theatre Proscenium Walls
Paragraph 6.19.9

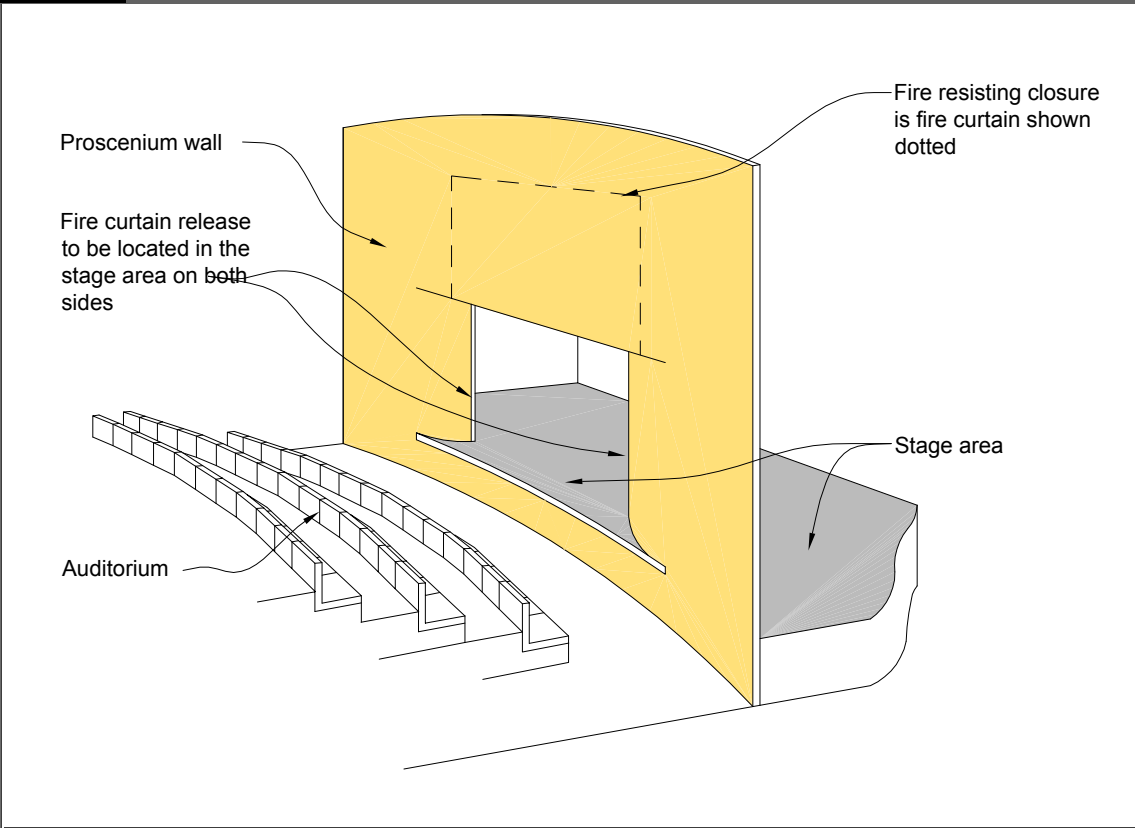

Notes:

1. Any glazing to proscenium wall shall be *insulated*.
2. Where the theatre is sprinkled, either sprinklers or drenchers shall be installed on both sides of the wall above the proscenium opening.

6.19.10 The *fire* curtain when released shall free fall, and overlap the opening to inhibit the passage of smoke and flames. An emergency curtain release device shall be located in the stage area on both sides of the opening.

6.19.11 Uninsulated glazing is not permitted in proscenium walls.

Protected shaft access panels

6.19.12 Access panels to *protected shafts* shall have the *fire* resistance and smoke control performance appropriate to their location as required by Table 6.1. They shall be capable of being opened only with a special tool.

Lift landing doors

6.19.13 *Doorsets* (lift landing doors) opening into lift shafts which are *protected shafts* shall be *fire doors* complying with Table 6.1. The *FRR* is based on the rating for the *protected shaft*. Table 6.1 describes how this is applied and the requirements for *insulation* and smoke control. Lift landing doors need not be *fire* rated from the shaft side.

Amend 4
Oct 2005

COMMENT:

This requirement does not apply to lifts meeting the provisions of Paragraph 3.12.3 for a passenger lift within a vertical *safe path*.

Fire dampers

6.19.14 Unless fully enclosed by *construction* with a *FRR* of no less than that required for the *fire separation*, any air duct passing through a *fire separation* shall be equipped with a *fire damper*, which in the event of duct failure or collapse, closes the opening through the separation. The *fire damper* shall have a *FRR* of no less than that of the *fire separation*, and shall be readily accessed for servicing.

COMMENT:

Fire dampers are not effective in stopping smoke and are thus not required in *smoke separations*. Smoke control in ducts is affected by smoke control devices in the air-handling system. Refer Paragraph 6.23.2.

Amend 5
Oct 2005 |

Fire shutters

6.19.15 Where a floor has a service opening (e.g. for stairs, conveyor, forklift access, or similar installation), not used as part of an *escape route*, and is fitted with a *fire shutter*, the floor may be treated as a *fire separation*.

COMMENT:

Any floor having any permanent opening is treated as an *intermediate floor*, and the smoke control requirements of Paragraphs 6.21.3 and 6.21.4 apply.

6.19.16 The *fire shutter* shall be automatically activated by a signal from any installed detector system, e.g. smoke or heat detectors, or sprinklers.

6.19.17 A *fire shutter* shall include a device to retard the rate of closing to no more than 150 mm per second.

6.20 Interior Surface Finishes, Floor Coverings and Suspended Flexible Fabrics

General principles

6.20.1 Within individual *household units* of *purpose groups* SR and SH there are no restrictions on the use of suspended flexible fabrics, and the only *surface finish* requirements are those given in Table 6.3 for *foamed plastics*.

6.20.2 For other *purpose groups* the *surface finish* requirements, which depend on the specific *purpose group* and location, are given in Table 6.2. These may be modified in accordance with Paragraph 6.20.5 where sprinklers are used.

6.20.3 In unsprinklered *firecells*, in any position not covered by the exceptions of Paragraphs 6.20.1 and 6.20.4, interior *surface finishes* on walls and ceilings shall have a *SFI* of no greater than 9, and where the *SFI* exceeds 5, the *SDI* shall not exceed 8.

Exceptions

6.20.4 *Surface finish* requirements do not apply to:

- a) Electrical switches, outlets, cover plates and similar small discontinuous areas.
- b) Pipes and cables.
- c) *Handrails* and general decorative trim such as architraves, skirtings and window components including reveals.
- d) Damp-proof courses, seals, caulking, flashings, thermal barriers in cold store walls, and ground moisture barriers.
- e) Timber joinery and structural timber *building elements* such as columns, beams and portals.
- f) Individual *doorsets* and continuous areas of permanently installed openable wall partitions, having a surface area of not more than 25% of the room floor area or 5 m², whichever is the greater.

COMMENT:

This provision effectively provides an exemption for *surface finishes* on most door leaves but not for folding or similar doors used to divide spaces into separate rooms.

Sprinklers and foamed plastics

6.20.5 In *firecells* constructed without foamed plastics, and equipped with sprinklers, only the ceilings need comply with the *SFI* and *SDI* requirements of Table 6.2. Where foamed plastics building materials are used in wall, ceiling or roof systems, the *surface finish* requirements of Paragraphs 6.20.11 to 6.20.13 and Table 6.2 shall apply to the foamed plastics materials whether or not sprinklers are installed.

Trampers' huts

6.20.6 In trampers' huts used for overnight accommodation in remote locations, wall and ceiling linings complying with Table 6.2 row 4 are acceptable provided that:

- a) The *occupant load* is no greater than 20, and
- b) All sleeping spaces have no fewer than two *escape routes*. One *escape route* may be an outward opening window complying with Paragraph 3.18.

COMMENT:

Trampers' huts are backcountry accommodation where access is by tramping. The hut occupants are self-reliant and using the hut for convenience. They recognise that this form of activity involves a measure of risk.

CS and CL purpose groups

6.20.7 *Firecells* with a *FHC* of 1 in *purpose groups* CS or CL, or any classrooms, passageways and corridors of educational buildings need not comply with Table 6.2 (rows 2 and 3) provided all the following conditions are satisfied:

- a) The *occupant load* is less than 250, and
- b) The *firecells* are at ground floor level and are served by at least two *exitways* or *final exits*, and
- c) The *SFI* is not greater than 7 and the *SDI* not greater than 5 for surfaces 1.2 m or more above floor level, and

- d) The *SFI* is not greater than 8 and the *SDI* not greater than 6 for surfaces less than 1.2 m above floor level.

COMMENT:

This provision allows for materials such as painted particleboard to be used from floor level to a height of 1.2 m where rapid escape is possible.

Flooring

6.20.8 Flooring shall be either *non-combustible*, or have a low radius of effects of ignition (assessed according to BS 5287) when tested to the BS 4790 *standard test* for flammability of floor coverings; whenever that floor covering serves:

- a) *Exitways* for all *purpose groups*, or
- b) Any space occupied by *purpose groups* SC or SD.

6.20.9 Paragraph 6.20.8 applies to flexible finishes such as carpets, vinyl sheet or tiles, and to finished or unfinished floor surfaces.

6.20.10 In *firecells* equipped with sprinklers the flooring need not comply with the requirements in Paragraph 6.20.8.

Foamed plastics building materials

6.20.11 Foamed plastics forming part of a wall, ceiling or roof system shall be protected from ignition. This requirement does not apply to *building elements* listed in Paragraph 6.20.4.

6.20.12 Protection from ignition shall be appropriate to the *building* occupancy and be achieved by using one or more of the following methods as required by Table 6.3:

- a) Installing *flame barriers*.
- b) Providing *fire-resistant surface finishes*.
- c) Restricting the flame propagation properties of the foamed plastics to the permitted levels.

Flame barriers

6.20.13 Where *flame barriers* are required by Table 6.3 they shall:

- a) Completely enclose the *foamed plastics* at sides, edges, openings, *penetration* locations and panel joints, and
- b) Comply with the *surface finish* requirements of Paragraphs 6.20.1 to 6.20.3, and
- c) When used in an *external wall* cladding assembly, be located between the interior *occupied space* and the *foamed plastics building* material.

COMMENT:

Care during *construction* is essential to ensure maintenance of the *integrity of flame barriers* particularly around *penetrations*.

Wood and wood products in floors

6.20.14 In any *firecell* which has a *firecell* below, the flooring may be of:

- a) Wood products provided it has a thickness of no less than 20 mm, or
- b) Another *combustible* material which complies with the requirements for a *flame barrier* as described in Appendix C Paragraph C10.1.

COMMENT:

Wood products include boards manufactured from wood fibres or chips bound by an adhesive.

Wood and wood products in walls and ceilings

6.20.15 In any *firecell*, when the required *F* or *S* rating is:

- a) 60 minutes or more, and the internal walls and ceilings are lined with wood or wood products thicker than 1.0 mm, unless the *firecell* is sprinklered the *S* rating shall be increased by applying the requirements of the next higher *fire hazard category* of Table 5.1.

- b) Less than 60 minutes, linings of wood products may be of any thickness provided they comply with the *surface finish* requirements for linings in Paragraphs 6.20.1 to 6.20.7.

COMMENT:

Wood includes any type of solid sawn timber or glue laminated timber.

Suspended flexible fabrics

6.20.16 Such materials shall be tested to the Standard test given in Appendix C. The requirements of Table 6.2 apply not only to curtains, drapes and similar ornamental fabrics which hang vertically, but also to flexible canopies and exposed building underlay, which may lie at or near the horizontal.

Amend 7
Nov 2008

Amend 4
Oct 2005

Amend 7
Nov 2008

Membrane structures

6.20.17 The fabric of structures such as tents, marquees or canopies used for *purpose groups* CM, CS and CL, shall meet the requirements of Table 6.2 when tested to the Standard test specified in Appendix C.

Amend 7
Nov 2008

Air-supported structures

6.20.18 In addition to the requirements of Paragraph 6.20.17, air-supported membrane structures shall satisfy all the following provisions:

- a) *Final exits* shall be *constructed* with frames which enable the *escape route* to remain operable should loss of pressure allow the membrane to collapse.
- b) Two air blowers shall be installed, each with the capacity to ensure full inflation under normal air leakage.
- c) The air blowers shall be electrically interlocked so that if one fails to operate, the other automatically starts.
- d) For *purpose group* CL, air blowers shall have power supplied from an automatic generator set, or alternatively, the structure shall have a supplementary blower powered by an automatic start internal combustion engine, either equipment being capable of maintaining full inflation pressure under normal leakage for 30 minutes.

6.20.19 The requirements for membrane structures need not apply to small *occupant loads* such as camping tents and horticultural applications.

Air ducts

6.20.20 Air ducts serving more than one *firecell* in *purpose groups* SC, SD, SA, SR, IE, CS, CL and CM shall have interior and exterior *surface finishes* satisfying the provisions of Table 6.2.

6.20.21 Where air ducts are contained wholly within a *protected shaft*, provided the shaft does not also contain lifts, only the interior *surface finish* of the air duct is required to comply with Table 6.2.

6.21 Smoke Control

Exitways – natural ventilation

6.21.1 An acceptable solution for natural ventilation of *exitways*, *purpose group* IE, is provided in Paragraphs 6.9.6 to 6.9.10.

Exitways – pressurisation

6.21.2 Where pressurisation of *exitways* is required by Table 4.1 (generally for *escape heights* of greater than 25 m), the system shall comply with AS/NZS 1668: Part 1 Section 9, and shall be activated by the detection system. A manual control shall also be provided, located in a position approved by the Fire Service.

Firecells with intermediate floors

6.21.3 Except where permitted by Paragraphs 6.21.4 to 6.22.14, smoke control in *firecells* containing *intermediate floors* shall be by specific *fire* engineering design.

COMMENT:

1. Specific *fire* safety requirements do not apply to *intermediate floors* in *firecells* which are *household units* in *purpose groups* SH and SR. (See definition of *intermediate floor*.)
2. *Firecells* with *intermediate floors* such as *theatres* (with galleries), shopping malls, offices and hotels with atrium shafts must be *constructed* to control both horizontal and vertical smoke spread.
3. For mechanical smoke control systems, extraction capacity calculations must take account of the buoyancy of hot smoke.

4. Calculations to determine the capacity of a smoke extract system are more complex than those needed for normal air handling at ambient temperatures. The heat and smoke plume rising from a *fire* in the common space in an atrium obtains initial buoyancy from the *fire*, and the extent of this buoyancy depends on the size of the *fire* and the vertical distance and route through which the smoke rises. *Fire* engineering calculations should take account of the likely *fire* size resulting from the specific use of the *building*.

5. The *fire* plume entrains cold air as it rises, resulting in a cooling and reduction in buoyancy towards the top of the plume. The smoke accumulating at the top of the space containing the *fire*, will, if not extracted, build downwards. It is important that the bottom of the smoke layer is kept at a height above the heads of any occupants, and the designer needs to understand and allow for the complex air flow mechanisms involved.

6. The following documents provide useful information for the design of smoke control systems:

- NFPA 92B Guide for smoke management systems in malls, atria, and large areas.
- “Design principles for smoke ventilation in enclosed shopping centres” – Morgan and Gardner, BRE Report 186, 1990.
- “Design approaches for smoke control in atrium buildings” – Hansell and Morgan, BRE Report 258, 1992.
- Klote and Milke, Design of Smoke Management Systems. ASHRAE 1992.
- Milke and Klote, Smoke Management in Large Spaces in Buildings. Building Control Commission, State of Victoria, Australia, 1998.

6.21.4 These acceptable solutions for smoke control apply to *firecells* with *intermediate floors* which meet either of the following criteria:

- a) The *firecell* has limited area *intermediate floors* on one level complying with Paragraphs 6.21.5 and 6.21.6, or
- b) The *firecell* is a *limited area atrium* meeting the requirements of Paragraphs 6.22.1 to 6.22.14.

COMMENT:

1. The solutions given for volume of smoke reservoirs, natural smoke ventilation and mechanical smoke extraction of *firecells* with *intermediate floors*, are applicable in cases where the *firecells* cannot be treated as single floor *firecells* but have low *occupant loads* which do not warrant specific *fire* engineering design. Specific design is required to determine vent areas or extract capacities for high *occupant loads* or where *intermediate floors* are more than 7.0 m above the *firecell* floor.

2. The solutions in Paragraphs 6.21.3 to 6.22.14 are based on:

- An objective of maintaining a smoke layer at a height of at least 2.0 m above the highest *intermediate floor* open to the atrium space. That height is retained for an indefinite time (for the assumed *fire* sizes) with natural smoke venting and mechanical smoke extract, and for 3.0 minutes for unvented smoke reservoir options.
- An assumed steady state design *fire*, for natural smoke ventilation and mechanical smoke extract, with a heat release rate of 2.5 MW.
- An αt^2 growth rate design *fire*, for unvented smoke reservoirs, reaching a heat release rate of 1.44 MW at 180 seconds and occupants of the highest *intermediate floor* are assumed to have escaped.
- A smoke production rate based on McCaffrey's *fire* plume correlation being a function of heat release rate and height to the underside of the smoke layer.
- Natural ventilation areas derived from formulae given in BRE Report 258, "Design approaches for smoke control in atrium buildings", G O Hansell and H P Morgan.
- Make-up air ventilation areas for mechanical smoke extract based on a maximum air velocity of 5 m/s.
- Effects of balcony spill plumes are ignored.

3. Reference should also be made to:

- Paragraph 3.4.6 – *open path* length on *intermediate floors*.
- Paragraph 3.9.13 – escape from a *firecell* via an *intermediate floor*.
- Paragraph 3.16.3 – *exitway* from an upper or *intermediate floor* in *purpose group* CL.
- Paragraph 6.14.3 – *FRR* for *intermediate floors*.

Firecells with limited area intermediate floors

6.21.5 A *firecell* with *intermediate floors* satisfying the following conditions may be treated as a single floor *firecell* and a smoke control system Type 10 or Type 11 is not required where:

- a) The *fire hazard category* of the *firecell* is no greater than 3, and
- b) Where there are two or more separate *intermediate floors*, the levels of those floors above the *firecell* floor differ by no more than 1.0 m, and
- c) The total *occupant load* on all *intermediate floors* is not greater than 100, and

d) The total area of the *intermediate floors* is no greater than allowed by Paragraph 6.21.6.

6.21.6 The total area of limited area *intermediate floors* within the *firecell* shall not exceed:

- a) 20% of the area of the *firecell* floor, not including the area of the *intermediate floor(s)*, where the *intermediate floor(s)* are enclosed or partitioned, or
- b) 40% of the area of the *firecell* floor, not including the area of the *intermediate floor(s)*, where the *intermediate floor(s)*:
 - i) are completely open, or
 - ii) if enclosed or partitioned, a Type 4 or Type 7 alarm system with smoke detection is installed throughout the *firecell*.

Amend 7
Nov 2008

Amend 7
Nov 2008

COMMENT:

1. The smaller (20%) floor area is a concession for spaces used essentially for storage with a low *occupant density*.
2. *Firecells* containing limited area *intermediate floors* require the same *fire safety precautions* as single level *firecells* having the same total *occupant load* and *escape height*. Examples of *buildings* having *intermediate floors* which could meet these requirements are:

- Factories and warehouses.
- Churches and halls.
- Small *theatres*.
- Gymnasiums.
- Shops.
- Offices.

6.22 Limited Area Atrium Firecells

6.22.1 An atrium *firecell building* contains *occupied spaces* which open onto a common enclosed space (atrium) at different levels. This type of *construction* is seen in some multi-level shopping complexes. *Limited area atrium firecells* (see Figure 6.14) have restrictions on the number, height and total area of *intermediate floors*, and shall be restricted to *purpose groups* CS, CL, CM, WL, IA, SA and SR with a *fire hazard category* of not greater than 2. *Fire safety* requirements depend on the number of *escape routes*, *occupant load* and the method of smoke control.

Figure 6.14: Smoke Control for Limited Area Atrium Firecells with No More than Three Floor Levels
Paragraphs 6.22.1 and 6.22.8

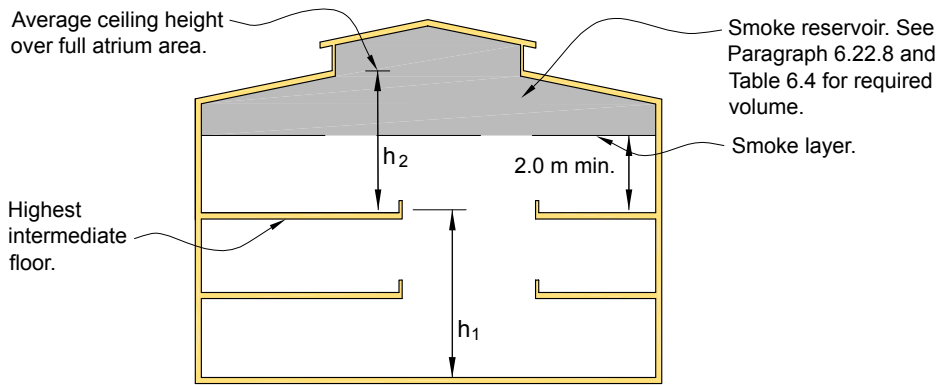

(a) Non-vented smoke reservoir

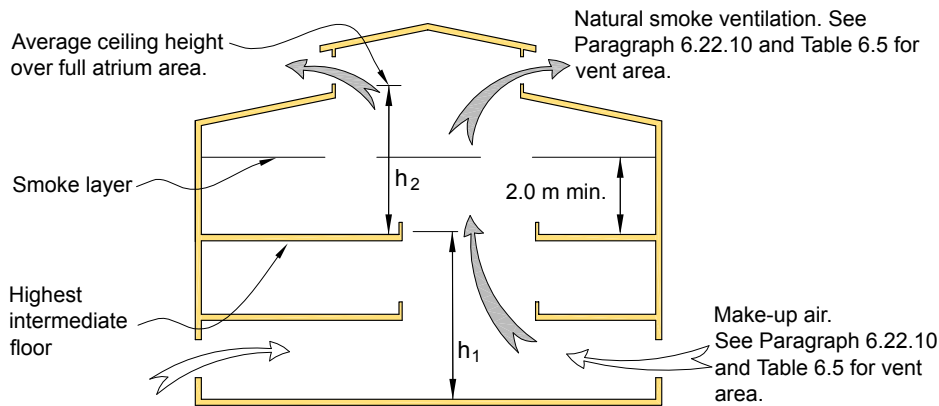

(b) Natural smoke ventilation

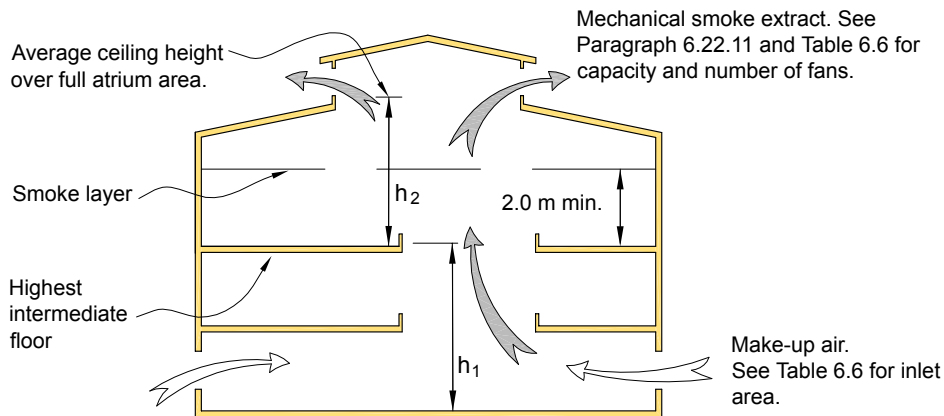

(c) Mechanical smoke extract

Notes:

1. h_1 is the height of the highest *intermediate floor* above the *firecell* floor. h_1 shall not exceed 7.0 m.
2. h_2 is the average floor to ceiling height from the highest *intermediate floor*.
3. Specific *fire* engineering design is required where the highest *intermediate floor* is more than 7.0 m above the *firecell* floor level.

6.22.2 *Limited area atrium firecells* shall meet all the following requirements:

- a) No more than two levels of *intermediate floor*.
- b) No *intermediate floor* located more than 7.0 m above the *firecell* floor.
- c) Where an *intermediate floor* has only a single *escape route*, that floor area shall be no greater than 200 m² and the *occupant load* no greater than 50. Only one such floor shall be permitted at any one level in the atrium.
- d) Where the *intermediate floor* has two or more *escape routes*, and the *occupant load* exceeds 100, at least one *escape route* from that floor shall be a *safe path*.
- e) The total area of all *intermediate floors* shall be no greater than 500 m².
- f) The total *occupant load* on all *intermediate floors* shall be no greater than 500 where a smoke ventilation or extraction system is installed, or 250 where smoke control is by way of a smoke reservoir only.
- g) A Type 4 (or Type 7 if sprinklered) alarm system shall be installed with smoke detection throughout the *firecell*.

Atrium dimensions

6.22.3 The minimum horizontal separation between *occupied spaces* across the atrium shaft shall be:

- a) 4.0 m for sprinklered *firecells*, or
- b) 6.0 m for unsprinklered *firecells*. Between an *occupied space* and a wall or non-*occupied space* the separation may be reduced to 4.0 m.

COMMENT:

The minimum separation requirement is needed to allow the smoke plume to rise without spreading to the *occupied spaces* on sides of the atrium. A reduction for sprinklers assumes that the sprinklers will limit the *fire* size.

6.22.4 Escalators, lifts or *stairways* in the atrium shaft may be ignored when determining the separation provisions of Paragraph 6.22.3.

6.22.5 Where all the highest *intermediate floors* are smoke separated from the atrium shaft, the shaft height above that floor level may be used as part of the smoke reservoir required by Paragraph 6.22.7.

Sprinkler systems

6.22.6 Sprinklers, where required, shall be located and installed in accordance with NZS 4541 or NZS 4515 (if within its scope of application), as modified by Appendix D.

Amend 7
Nov 2008

COMMENT:

Where the underside of the roof over an atrium space is more than 10 m above the *firecell* floor, conventional sprinkler installation may not be effective. Sprinkler systems intended to control a *fire* on the floor directly below the high roof therefore must be specifically designed and installed for effective *fire* control.

Atrium smoke control methods

6.22.7 Smoke control in *limited area atrium firecells* is required for sufficient time to allow occupants to safely escape to a *safe place*. There are three methods of smoke control:

- a) Provision, at the top of the atrium, of a smoke reservoir with sufficient volume to hold, above a safe level, smoke generated from a *fire* until occupants have escaped, or
- b) Provision of a smoke reservoir and natural smoke ventilation to effectively clear smoke to the outside, or
- c) Provision of a smoke reservoir and mechanical smoke extract to remove smoke to the outside.

Smoke reservoirs

6.22.8 The required smoke reservoir volume depends on the chosen smoke control method (see Figure 6.14) and shall be determined as follows:

- a) For all three methods the relevant tables are designed to ensure the smoke layer falls to a level no lower than 2.0 m above the highest open *intermediate floor*. Before using the tables it is necessary to determine:

- i) the height of the highest *intermediate floor* above the *firecell* floor level, and
- ii) the average floor to atrium ceiling height measured from the highest open *intermediate floor*, and
- iii) that the plan dimensions do not exceed the provisions of Paragraph 6.22.9.

COMMENT:

If the highest *intermediate floor* is not open to the atrium space, but is enclosed by a *smoke separation*, the average height (described in Paragraph 6.22.8 a) ii) may be measured from the next lower *intermediate floor*. This permits the atrium space between enclosed *intermediate floors* to be used as part of the smoke reservoir.

- b) For atriums with no natural smoke ventilation or mechanical smoke extraction, the reservoir volume shall meet the requirements of Table 6.4.
- c) For atriums having natural smoke ventilation or mechanical smoke extract, the smoke reservoir requirements shall be satisfied by complying with the vent area and extract provisions of Tables 6.5 and 6.6.

6.22.9 A smoke reservoir shall be no greater than 1000 m² in plan area and have a maximum dimension of 60 m in any direction.

COMMENT:

1. The restriction on smoke reservoir area prevents excessive cooling which could reduce smoke buoyancy.
2. It is acceptable to have more than one smoke reservoir in a *limited area atrium firecell* but the restriction on the maximum area of *intermediate floors* (Paragraph 6.22.2) still applies.

Natural smoke ventilation

6.22.10 For natural smoke ventilation, the minimum permitted open area for smoke vents at the top of the atrium and for make-up inlet air vents within 1.5 m of the *firecell* floor level, shall be determined from Table 6.5. There is no specific requirement for the

horizontal distribution of inlet and smoke vent areas around the atrium perimeter, as the limitation on smoke reservoir size (Paragraph 6.22.9) ensures effective natural smoke ventilation. Flexibility in the respective areas of inlet and smoke vents is permitted by using any of the following combinations:

- a) Inlet vents with 200% and smoke vents with 100% of the area required by Table 6.5, or
- b) Both inlet and smoke vents with 135% of the area required by Table 6.5, or
- c) Inlet vents with 112.5% and smoke vents with 225% of the area required by Table 6.5.

COMMENT:

Although there is no specific requirement for the distribution of inlet and smoke vents, Paragraph 6.22.13 applies and they should, where practicable, be distributed to avoid pockets of smoke stagnation within the smoke reservoir.

Mechanical smoke extract

6.22.11 For mechanical smoke extract systems, smoke extract rate and inlet vent areas for make-up air shall comply with Table 6.6. The number of extract points required by Table 6.6 is a minimum but, in no case shall extract points be located closer than 10 m apart and there shall be at least one extract point for every 20 m over the length of the atrium.

6.22.12 The mechanical smoke extract system shall be:

- a) Capable of removing smoke from all spaces within the *firecell*,
- b) Activated automatically by the smoke detection system (required by Paragraph 6.22.2 g)) in response to *fire* anywhere in the *firecell*. A manual control shall also be provided, located in a position approved by the Fire Service,

Amend 5
Oct 2005

- c) Capable of operating independently of or in conjunction with the *fire* mode of any other ventilation system in the *building*,
- d) Protected from the effects of *fire* to ensure continuous operation for no less than 60 minutes from the time smoke is detected,
- e) Equipped with exhaust fans capable of running continuously in temperatures of 40°C, and for no less than 60 minutes at a smoke/air temperature of 200°C.

Inlet vents and smoke vents

6.22.13 Regardless of the method chosen, all smoke and inlet vents shall be permanently open or *constructed* to open automatically in a response to smoke detector activation in the event of *fire*. Inlet vents shall be located to permit free air flow to the atrium space at *firecell* floor level.

Smoke vents shall be located so that smoke is discharged:

- a) At least one full floor height above where emergency services may need to operate, and
- b) Remote from intakes for *HVAC* systems, and
- c) Remote from any *final exits* or external *safe paths*, and
- d) So that the system will operate effectively in all wind directions.

6.22.14 Mechanical smoke extraction systems and natural smoke ventilation systems with automatic opening vents in *limited area atrium firecells* shall be activated by smoke detectors which:

- a) Incorporate a system of automatically verifying the first signal before actively responding, and
- b) Sample air from all spaces within the *firecell* by having:
 - i) point detectors located in accordance with NZS 4512, and

- ii) beam detectors, directed to scan across the atrium, and located no higher than the first or second levels above the *firecell* floor. The number shall ensure effective coverage of the space below, taking account of the mounting height and the characteristics of the detector selected.

COMMENT:

1. Signal verification aims to avoid the false alarm costs resulting from unnecessary system operation and disruption of occupant activities, while still promptly calling assistance in a genuine case of *fire*. False alarms may arise from detector system malfunction, or from genuine activation in ambient conditions which the detector incorrectly senses as a smoke condition.
2. Smoke detectors at the perimeter of *intermediate floors* allow warning to be given before smoke spills into the atrium connecting space. Beam detectors cater for a *fire* near the centre of the atrium floor, from which smoke may plume vertically without encountering other detectors.

6.23 Building Services Plant

Automatic activation

6.23.1 The smoke detection system when activated shall automatically:

- a) Open all vents which are part of the smoke extraction and air supply systems,
- b) Start smoke extraction and air supply systems, and *exitway* pressurisation where installed,
- c) Turn off air-conditioning and mechanical ventilation plant which is not required or designed for *fire* safety, and
- d) Start the emergency power supply system where required by Table 4.1.

Air-handling systems

6.23.2 Table 4.1 specifies a Type 9 *FSP* where it is necessary to prevent the recirculation of smoke through an air-handling system to other *firecells* in a *building*. Appendix A Paragraph A2.1 gives the requirements for those systems.

Emergency power supply

6.23.3 Where required by Table 4.1, an emergency power supply system complying with NZS 6104 shall be installed to ensure that in a *fire*, emergency power is available for:

- a) Operating all components of the smoke control system,
- b) Returning all passenger carrying lifts to the floor level of the lowest *final exit*, and for operating designated *fire* fighters' lifts, and
- c) Operating the emergency lighting system. (See NZBC F6 for the requirements of lighting for emergency.)

6.23.4 The emergency power supply shall have sufficient capacity for continuous operation of all the systems in Paragraph 6.23.3 for a period of time no less than that required for emergency lighting in F6/AS1 Paragraph 1.1.3.

Amend 5
Oct 2005 |

Amend 5
Oct 2005

Table 6.1: Closures in Fire and Smoke Separations
Paragraphs 5.6.5 c), 6.19.1, 6.19.3, 6.19.4 c) and d), 6.19.12 and 6.19.13

Minimum Performance	Location of the closure	Row
-/-	In a <i>final exit</i> .	1
-/- Sm	In a separation required only for smoke control, e.g. between an <i>open path</i> and a <i>protected path</i> in all <i>purpose groups</i> (Notes 1 and 2).	2
-*/*	In a <i>fire separation</i> between a <i>protected shaft</i> and <i>firecell</i> , which is not an <i>exitway</i> , where the <i>escape route</i> does not pass through the closure.	3
	In a <i>fire separation</i> between <i>firecells</i> which are neither SR, SA, SC, SD <i>purpose groups</i> nor <i>other property</i> , and where the <i>escape route</i> does not pass through the closure.	
-*/* Sm	In a <i>fire separation</i> between <i>firecells</i> which are SR, SA, SC or SD <i>purpose groups</i> or <i>other property</i> .	4
	All closures in a <i>fire separation</i> between <i>firecells</i> where the <i>escape route</i> passes through any closure in that <i>fire separation</i> .	
	In a <i>fire separation</i> between an unsprinklered <i>firecell</i> and a <i>safe path</i> or <i>protected path</i> . (Note 2).	
-*/- Sm	In a <i>fire separation</i> between an unsprinklered <i>protected shaft</i> and a <i>safe path</i> or <i>protected path</i> (Note 2 and for lift doors Note 3).	5
	In a <i>fire separation</i> between sprinklered <i>firecells</i> where the closure is part of an <i>escape route</i> .	
	In a <i>fire separation</i> between a sprinklered <i>firecell</i> and a sprinklered <i>safe path</i> . (Note 2).	
	In a <i>fire separation</i> between a sprinklered <i>firecell</i> and a sprinklered <i>protected shaft</i> (Note 3 for lift doors).	

Notes:

Sm indicates that the closure has smoke control capability.

* means the *FRR* required for the *fire separation*, except that the *insulation* rating need be no greater than 30 minutes.

1. Paragraph 3.17.12 requires *smoke control doors* (i.e. -/- Sm) to be used in certain circumstances.
2. Smoke control capability (Sm) may be deleted if the *safe path*, or *protected path* is pressurised (*fire safety precaution* Type 13). This is because the airflow created by pressurisation is intended to inhibit smoke *penetration*.
3. Smoke control capability Sm may be deleted for *doorsets* opening into a lift shaft if:
 - a) The *firecell* is sprinklered and has an automatic smoke detection system, or
 - b) A *smokecell* is placed between the doors and the rest of the *firecell*, but refer to Paragraph 3.12.3 for when a lift shaft can be included within a vertical *safe path* permitting a door without smoke control capability to be used.

Amend 5
Oct 2005

Table 6.2: Requirements for Interior Surface Finishes and Suspended Flexible Fabrics to Inhibit Fire Spread
Paragraphs 6.18.2 d), 6.20.2, 6.20.5, 6.20.7, 6.20.16, 6.20.20 and 6.20.21

Building elements	Purpose group or location (Note 1)	Maximum permitted index			Row
		SFI	SDI	FI	
Walls, ceilings (Note 2)	Exitways in all <i>purpose groups</i> .	0	3	-	1
	Sleeping areas in <i>purpose groups</i> SC and SD.				
	All <i>occupied spaces</i> in <i>purpose groups</i> CS and CL excluding <i>exitways</i> (see also Paragraph 6.20.7).				
	All <i>occupied spaces</i> in <i>purpose group</i> CM where the <i>occupant load</i> is greater than 50.	2	5	-	2
	Sleeping areas in <i>purpose group</i> SA (see also Paragraph 6.20.6 for trampers' huts).				
	Passageways, corridors and <i>stairways</i> not being part of an <i>exitway</i> in all <i>purpose groups</i> except SH and SR.	7	5	-	3
	Minimum requirement for all <i>occupied spaces</i> in all <i>purpose groups</i> except within <i>household units</i> in <i>purpose groups</i> SR and SH.	5 or 9	10 8	-	4
Within individual <i>household units</i> in <i>purpose groups</i> SR and SH.		Nil requirement		5	
Flooring (coverings)	Exitways.	Non-combustible, or have low radius of effects of ignition (see Paragraph 6.20.8).			6
	Any <i>occupied space</i> in <i>purpose groups</i> SC and SD.				
Ducts for HVAC systems	Internal surfaces.	0	3	-	7
	External surfaces.	7	5	-	8
Acoustic treatment and pipe insulation	Within air-handling plenum in <i>purpose groups</i> SC, SD, SA and SR.	7	5	-	9
Suspended flexible fabrics	Exitways serving <i>purpose groups</i> SC, SD, SA, SR and CO.				
	All <i>occupied spaces</i> in <i>purpose groups</i> CS and CL including <i>exitways</i> .				
	All <i>occupied spaces</i> including <i>exitways</i> in <i>purpose group</i> CM where <i>occupant load</i> is greater than 50.	-	-	12	10
	Underlay to exterior cladding or roofing when exposed to view in <i>occupied spaces</i> in <i>purpose groups</i> SC, SD, SA, WL, WM, WH, WF, CO, CM, CS, CL and IE.			5	11
Membrane structures	<i>Purpose groups</i> CM, CS and CL.	-	-	12	12
Column 1	2		3		
Key:	SFI = spread of flame index SDI = smoke developed index FI = flammability index	(The smaller the index number the more stringent the requirement)			

Amend 7
Nov 2008

Notes:

- For the purposes of this table, the term "*occupied spaces*" means a space that can be expected to be occupied during normal use of the *building* by its intended occupants. It does not include *concealed spaces* or ceiling cavities which may be accessed only through a hatch, or plant rooms and the like occupied only for maintenance purposes.
- Sprinklered firecells:** see Paragraph 6.20.5 for reduced requirements in sprinklered *firecells*.

Table 6.3: Foamed Plastics – Protection from Ignition
Paragraphs 6.20.1, 6.20.12 and 6.20.13

Application	Required properties (see Note)		
	Purpose Groups SR, SA, SH	Purpose Groups SC, SD	Purpose Groups CS, CL, CO, CM, WL, WM, WH, WF, IA, ID
Sleeping areas	fb + p	fb + p	n/a
Exitways unsprinklered	fb + p	n/a	fb + p
Exitways sprinklered	fb + p	fb + p	fb + p
Non-sleeping <i>occupied spaces</i> unsprinklered	fb + p	n/a	fb + p
Non-sleeping <i>occupied spaces</i> sprinklered	sf + p	fb + p	sf + p
<i>Concealed spaces</i>	p	fb + p	p

Key:

p *foamed plastics* shall comply with the flame propagation criteria as specified in AS 1366 for the type of material being used.

sf *surface finish* shall comply with Paragraph 6.20.3 for *spread of flame index (SFI)* and *smoke developed index (SDI)*.

fb *flame barrier* complying with Appendix C Paragraph C10.1.

Note:

Applies to all *foamed plastics* forming part of a wall, ceiling or roof system. **The exemption given by Paragraph 6.20.5 for *surface finish* requirements on walls in sprinklered firecells does not apply where *foamed plastics* are used.**

Table 6.4: Volumes of Unvented Smoke Reservoirs for Limited Area Atrium Firecells
Paragraph 6.22.8 and Figure 6.14

Height of highest intermediate floor h_1 (m)	Average floor to atrium ceiling height from the highest open intermediate floor level h_2 (m)				
	4	5	6	7	8
2.5	1030	1450	1820	2150	2460
3.0	1130	1580	2000	2370	2720
3.5	1220	1720	2170	2580	2970
4.0	1300	1850	2340	2790	3210
5.0	1470	2090	2670	3200	3690
6.0	1630	2330	2980	3580	4150
7.0	1780	2560	3280	3960	4600

Minimum volume of smoke reservoir (m³)

Table 6.5: Natural Smoke Ventilation of Firecells with Intermediate Floors
Paragraphs 6.22.8, 6.22.10 and Figure 6.14

Height of highest intermediate floor h_1 (m)	Average floor to atrium ceiling height from the highest open intermediate floor level h_2 (m)			
	4	5	6	7 or greater
2.5	8	7	6	5
3.0	10	8	7	6
3.5	12	10	9	8
4.0	15	12	11	10
5.0	23	18	16	14
6.0	32	26	23	20
7.0	44	36	31	28
Natural smoke ventilation area (m²)				

Table 6.6: Mechanical Smoke Extraction of Firecells with Intermediate Floors
Paragraphs 6.22.8, 6.22.11 and Figure 6.14

Height of highest intermediate floor h_1 (m)	Average floor to atrium ceiling height from the highest open intermediate floor level h_2 (m)				Required total extract rate (m ³ /s)	Required free inlet area for make-up air (m ²)
	4	5	6	7 or greater		
2.5	2	1	1	1	17	2.4
3.0	2	1	1	1	19	2.9
3.5	2	1	1	1	22	3.4
4.0	2	1	1	1	25	4.0
5.0	3	2	1	1	32	5.4
6.0	5	2	1	1	39	6.9
7.0	6	3	2	1	48	8.7
Minimum number of extract points for mechanical smoke extract						

Acceptable Solution C/AS1

Part 7: Control of External Fire Spread

7.1 General Principles

7.1.1 External walls and roofs (see Figure 7.1) shall be constructed to avoid:

a) Vertical fire spread up the outer face of the external wall of a building.

b) Horizontal fire spread by thermal radiation or structural collapse, which could endanger:

- i) other property, or
- ii) adjacent buildings containing purpose groups SC, SD, SA, SR or SH, or
- iii) external safe paths.

COMMENT:

1. Fire can spread vertically up walls via combustible external cladding, voids within walls, or gaps between floor perimeters and walls as could occur in curtain walling (see Figures 6.11 and 6.12).
2. The degree of protection required by this acceptable solution depends on the purpose group and escape height for the firecell. See Paragraphs 7.9.10, and 7.11.

COMMENT:

Paragraph 5.9 identifies which primary elements providing structural stability during fire are required to be fire rated.

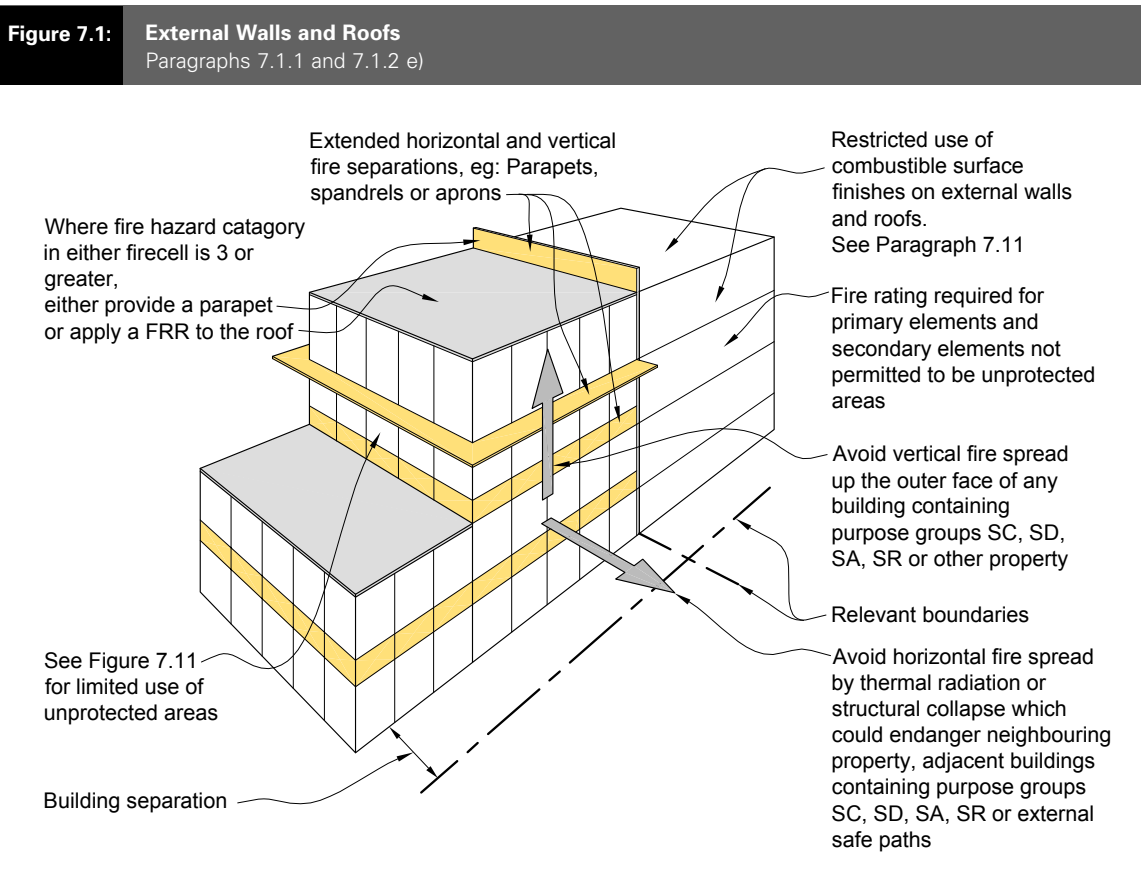

7.1.2 The necessary protection shall be achieved by one or a combination of:

- Building separation.
- Providing an *adequate FRR* for *primary* and *secondary elements*.
- Restricted use of *combustible surface finishes*.
- Limiting *unprotected areas*, including rooflights, where close to a *relevant boundary*.

e) Providing parapets, spandrels or aprons (see Figures 7.1 and 7.2).

f) Installing sprinklers (see Figure 7.2).

COMMENT:

Any alternative solution, such as a wall wetting system, shall be subject to specific *fire* engineering design.

7.1.3 The methods used shall be appropriate for the *escape height*, the *purpose groups* and the *fire hazard categories* within the *building*, and in accordance with the requirements of Paragraphs 7.3 to 7.11.

Figure 7.2: Spandrels, Aprons and Sprinklers
Paragraphs 7.1.2 e), f) and 7.9.12

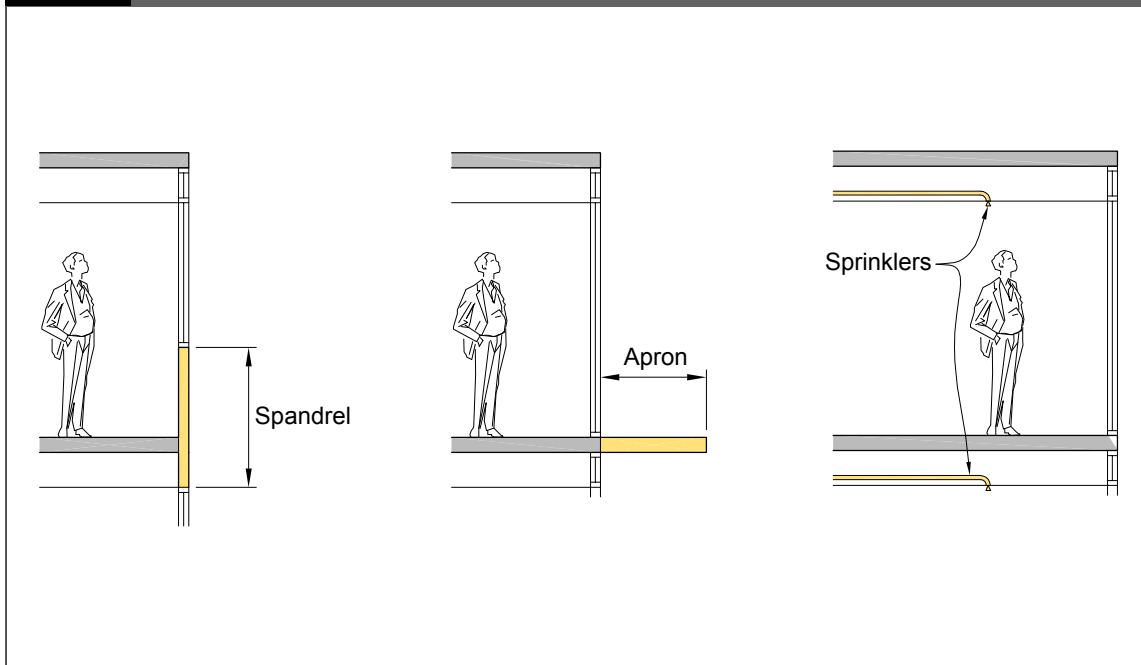

7.2 Separation of Legal Titles

7.2.1 When a *building* is subdivided into cross lease titles, company lease titles or unit titles, each title shall be separated from:

- a) An adjacent title, by *fire separations* having a *FRR* of no less than the greater of the *F* or *S ratings* as determined from Paragraph 5.5, and
- b) Any area in common (unless Paragraph 7.2.2 applies), by *external walls* complying with Paragraph 7.10, except that, if roofed, the area in common shall be a *firecell*, separated from adjacent titles by *fire separations* as determined in a) above. If the area in common is a *safe path* and the *FRR* required by Paragraph 6.9.2 or 6.9.3 is greater, the greater *FRR* shall apply.

COMMENT:

- 1. In a) above; vertical *fire separations* replace the need for *external walls* between titles. Floors between titles are also *fire separations* and provide the horizontal separation.
- 2. In b) above; where separate titles face each other across an unroofed area in common, it is necessary to apply the *FRR* requirements for *external walls*. In this situation a *notional boundary* is established between the titles, and the permitted *unprotected area* in the *external walls* of both titles are determined with respect to that *notional boundary*. When the area in common is roofed, the danger to life and adjacent property is increased, hence the need for greater precautions.

7.2.2 When a *building* is subdivided (as in Paragraph 7.2.1) and all the titles and any areas in common are sprinklered throughout, the requirements for *fire separations* of Paragraph 7.2.1 b) need not apply except that the requirements of Paragraphs 6.9.2 and 6.9.3 still apply.

Amend 7
Nov 2008

COMMENT:

The sprinkler system covering each title and the area in common should be regarded, for operational and maintenance purposes, as one system controlled by the body corporate for the whole *building*.

7.3 Horizontal Fire Spread from External Walls

Firecell separation

7.3.1 Specific separation requirements for *unprotected areas* in *external walls* shall be applied in the following circumstances:

- a) Where due to the configuration of a single *building*, or siting of other *buildings* on the same property, *external walls* of adjacent *firecells* are exposed to each other at an angle of 135° or less, and one or both *firecells* contain *purpose groups* SC, SD, SA, SR, SH or IE, or
- b) Where there are *unprotected areas* in *external walls* facing a *relevant boundary* to *other property* at an angle of 135° or less.

COMMENT:

- 1. When the vertical planes of two *external walls* of separate *firecells*, or of an *external wall* and a *relevant boundary* of *other property* (where the wall faces that *boundary*), intersect at an angle of 135° or less, there is potential danger of *fire* spread between *firecells* or to *other property*.
- 2. The location of the *relevant boundary* has a significant influence on the *fire safety precautions*. Readers are strongly advised to refer to the definition of *relevant boundary* as given at the beginning of this acceptable solution.

7.3.2 The degree of protection is dependent upon:

- a) The *firecell* size,
- b) The *fire hazard category* applicable to the *firecell*,
- c) Whether the *firecell* is sprinklered, and
- d) The *purpose groups* contained in adjacent *firecells* when on the same property.

7.3.3 The protection shall be achieved by *firecell* separation using one or more of the following approaches:

- a) Distance separation,
- b) Limiting *unprotected areas* in *external walls*,
- c) Using *fire resisting glazing*,
- d) Wing walls having no *unprotected areas*,
- e) Return walls (having no *unprotected area*) on the *firecell* of supposed *fire* origin.

Choosing calculation method

7.3.4 This acceptable solution provides four methods for determining the required distance separation and associated limits on *unprotected areas*.

The method adopted depends largely on the intersection angle. That is the angle produced between two horizontal lines, one being the line projected along the exterior face of the *firecell*, and the other being the *relevant boundary* (see Figure 7.3). For example, where *external walls* are parallel to one another, or to a *relevant boundary*, the intersection angle is zero degrees.

The following methods shall be applied depending on the intersection angle.

- a) For angles of 10° or less, apply Methods 1 or 2.
- b) For angles between 10° and 80° apply Method 3.
- c) For angles from 80° to 135° apply Method 4.
- d) For angles of 135° or greater there are no requirements and an *unprotected area* of 100% is permitted for the *external wall*.

7.3.5 Method 1 allows a combination of small *unprotected areas* and *fire resisting glazing*. It is the only method permitted for a wall or part of a wall less than 1.0 m from the *relevant boundary* and having an intersection angle of less than 80°.

7.3.6 Method 2, enclosing rectangles, applies only to the permitted *unprotected area* in *external walls* 1.0 m or more from the *relevant boundary*. This method has no provision for *fire resisting glazing*.

7.3.7 Methods 1 and 2 shall not be combined. It is not permissible to add areas of *fire resisting glazing* calculated by Method 1 to the permitted *unprotected area* calculated by Method 2.

7.3.8 Method 3 is a variation of Method 2 for *buildings* of irregular shape or having an intersection angle (see Paragraph 7.3.4) of between 10° and 80°.

7.3.9 Method 4, return walls and wing walls, is used where the intersection angle (see Paragraph 7.3.4) between the *external wall* of the *firecell* being considered, and the *relevant boundary* or adjacent *firecell*, is between 80° and 135°.

7.3.10 Regardless of the method adopted, all parts of an *external wall* other than allowable *unprotected areas*, shall have the appropriate *FRR* as determined by the relevant parts of this acceptable solution.

Check other external walls

7.3.11 The analysis shall be done for all *external walls* of the *building* to check the permitted *unprotected area* in each wall.

Sprinklered firecells

7.3.12 For Methods 2 and 3 (but not Method 1), if a *firecell* is sprinklered:

- a) The *unprotected area* in *external walls* determined from Table 7.2 may be doubled, or
- b) The distance between the *external wall* and the *relevant boundary* may be reduced to 70% of the value required by Table 7.2, but not reduced to less than 1.0 m.

COMMENT:

1. For example, take a *fire hazard category 3 building* which has an *external wall* with an enclosing rectangle height of 2.0 m and width of 10 m. Assume that the wall is located 2.3 m from the *relevant boundary*.

If the *building* is not sprinklered, the permitted *unprotected area* from Table 7.2/2 is 42%.

If the *building* is sprinklered either:

- a) The permitted *unprotected area* may be doubled to 84%, or
- b) The permitted *unprotected area* remains at 42%, but the distance to the *relevant boundary* may be reduced to 1.6 m which is 70% of the originally chosen *boundary* distance of 2.3 m for the unsprinklered *building*.

2. For sprinklered *firecells* using Method 4 see Paragraph 7.7.6.

Figure 7.3: Permitted Unprotected Areas in External Walls Adjacent to a Relevant Boundary
Paragraph 7.3.4



This example illustrates the situation where each of the methods 1, 2, 3 and 4 are used to restrict the size and/or location of *unprotected areas* in *external walls* close to the *relevant boundary* with *other property*.

Wall A: Intersection angle of 10° or less (shown as 8° in above example). If any part of the wall is within 1.0 m of the *relevant boundary* use Method 1. If the wall is 1.0 m or more from the *boundary* use Method 2.

Wall B: Intersection angle between 10° and 80° (shown as 62° in above example). Use Method 3 applying the case for *buildings* which are irregular or non-parallel to the *boundary*.

Wall C: Intersection angle from 80° to 135° (shown as 98° in above example). Use Method 4 for return walls and wing walls.

Notional boundary – firecells on the same property

7.3.13 For *firecells* under common ownership in the same *building*, or in separate *buildings* on the same property, it is necessary to use a *notional boundary* instead of the *relevant boundary*. In such cases, when applying Tables 7.1, 7.2 and 7.5, the words *relevant boundary* shall be interpreted as *notional boundary*.

COMMENT:

Table 7.3 applies only to the control of *fire* spread to *other property* and the term “*relevant boundary*” is correct for the appropriate column heading. Similarly, Table 7.4 applies only to *firecells* on the same property and “*notional boundary*” is the correct term in the column heading. For Tables 7.1, 7.2 and 7.5, the information applies to both *other property* and the same property. For simplicity, in those tables only the term *relevant boundary* has been used but should be treated as *notional boundary* when applying the tables to *firecells* on the same property.

7.3.14 Where one or both *firecells* on the same property contain *purpose groups* SC, SD, SA, SR, SH or IE, calculations shall be done separately for each *firecell* with respect to the chosen *notional boundary*.

Important considerations when using tables

7.3.15 In applying this acceptable solution it is essential to understand that:

- a) The methods have been produced to provide relatively quick answers directly from the tables for the most common situations where the *external wall* being considered is:
 - i) parallel to the *relevant* or *notional boundary*, or
 - ii) at right angles to the *relevant* or *notional boundary*.
- b) Where *buildings* are neither parallel nor at right angles to the *relevant* or *notional boundary*, adjustments must be made to the values derived from the tables.

COMMENT:

1. For *buildings* or *firecells* on the same property it is necessary to provide only for life safety. Protection of the *owner's* own property is not a *building code* requirement. The *owner* therefore has the flexibility to locate the *notional boundary* to best suit the *building* use and the level of risk the *owner* considers acceptable for *firecells* which are not *safe paths* or occupied by sleeping *purpose groups*.

2. Methods 1 to 4 and Tables 7.1 to 7.3 are based on the following assumptions:

- Emissivity of *fire* gases is 0.95.
- *Fire resisting glazing* reduces the radiation flux to 55% of the original value.
- The *fire resisting glazing* is square, which is a conservative assumption with respect to the radiation configuration factor.
- The received radiation is evaluated at a point 1.0 m beyond the *relevant boundary*, and on the *boundary* according to the criteria given below.

Fire Hazard Category	Emitted radiation from the fire kW/m ²	Maximum permitted received at 1.0 m beyond relevant boundary kW/m ²	Maximum permitted received on relevant boundary kW/m ²
1	87.6	18	30
2	108.4	17	30
3 and 4	151.6	16	30

3. The permitted “maximum received radiation” values (at 1.0 m beyond the *relevant boundary*), are higher than values commonly accepted at present. Those assume the absence of Fire Service intervention. While it is not possible to give 100% guarantee of timely Fire Service intervention, the history of past *fires* indicates that the risk of *fire* spread to adjacent property is low (approximately 0.3% of all structure *fires* according to NZFS Emergency Incident Statistics 1993-97). The historically low risk of *fire* spread is the basis for permitting the higher received radiation values.

7.4 Method 1 – Small Openings and Fire Resisting Glazing

7.4.1 The provisions for *external wall construction* are satisfied if:

- a) *Unprotected areas* (Type A) and areas of *fire resisting glazing* (Type B) are located to comply with Figure 7.4, and
- b) The remainder of the wall is *fire rated* equally for exposure to *fire* on both sides.

Size and spacing of Type A and Type B areas

7.4.2 Type A *unprotected areas* shall be no greater than 0.1 m². Type B areas of *fire resisting glazing* shall be no greater than permitted by Table 7.1 according to the distance from the *relevant boundary*.

7.4.3 The *fire resisting glazing* shall be rated for *integrity* and the *FRR* of both the glazing and *external wall* shall be derived from the *S rating* as described in Part 5.

7.4.4 There is no limitation on the spacing between adjacent Type A and Type B areas which occur in different *firecells*. Within a *firecell* the following requirements shall apply:

- a) Type A areas shall be no closer, both vertically and horizontally, than 1.5 m to another Type A or to a Type B area.
- b) Type B areas shall be no closer to one another, vertically or horizontally, than the dimensions X or Y shown on Figure 7.4.

COMMENT:

To determine dimensions X and Y, measure the width and height of both the adjacent Type B areas. The minimum value for X is the greater of the two widths, and for Y the greater of the two heights.

- c) Where Type B areas are staggered, rather than being aligned vertically or horizontally, the shortest distance, in any direction, between adjacent areas shall be no less than the greater of the X and Y measurements.

7.5 Method 2 – Enclosing Rectangles – Parallel Boundary

7.5.1 This method is applied to *external walls of buildings* which are parallel to or angled at no more than 10° to the *relevant boundary*.

7.5.2 The method is used to calculate the percentage of *unprotected area* in the *external wall* of each *firecell* and allows the acceptable distance to the *relevant boundary*, for each *fire hazard category*, to be read from Table 7.2.

7.5.3 The calculation steps (see Figures 7.5 and 7.6) are:

Step 1 Determine the location of the *relevant boundary* or, for *buildings* on the same property, the *notional boundary*.

Step 2 For the *external wall* of each *firecell*, draw a rectangle enclosing all *unprotected areas* (and the protected areas between them). Determine the dimensions of the rectangle, and refer to Table 7.2.

COMMENT:

1. Paragraphs 7.5.7 and 7.5.8 permit the enclosing rectangle to be applied to each floor level (rather than the whole *firecell*) in *household units of purpose groups* SH, SR and accommodation units of *purpose group* SA.
2. Paragraph 7.5.9 describes how to determine enclosing rectangle height on sloping sites, or where the *external wall* is not rectangular.

Step 3 Select the page of Table 7.2 for the applicable rectangle height (see Paragraph 7.5.5 for different rectangle heights).

Step 4 Select the panel in the table for the *fire hazard category* of the *firecell* being considered.

Step 5 Within that panel select the column for the appropriate rectangle width (see Step 9 Comment 2 for rectangle width limits, and Paragraph 7.5.5 regarding permitted interpolation).

Figure 7.4: Method 1 – Permitted Small Unprotected Areas and Fire Resisting Glazing
Paragraphs 7.4.1 a) and 7.4.4 b)

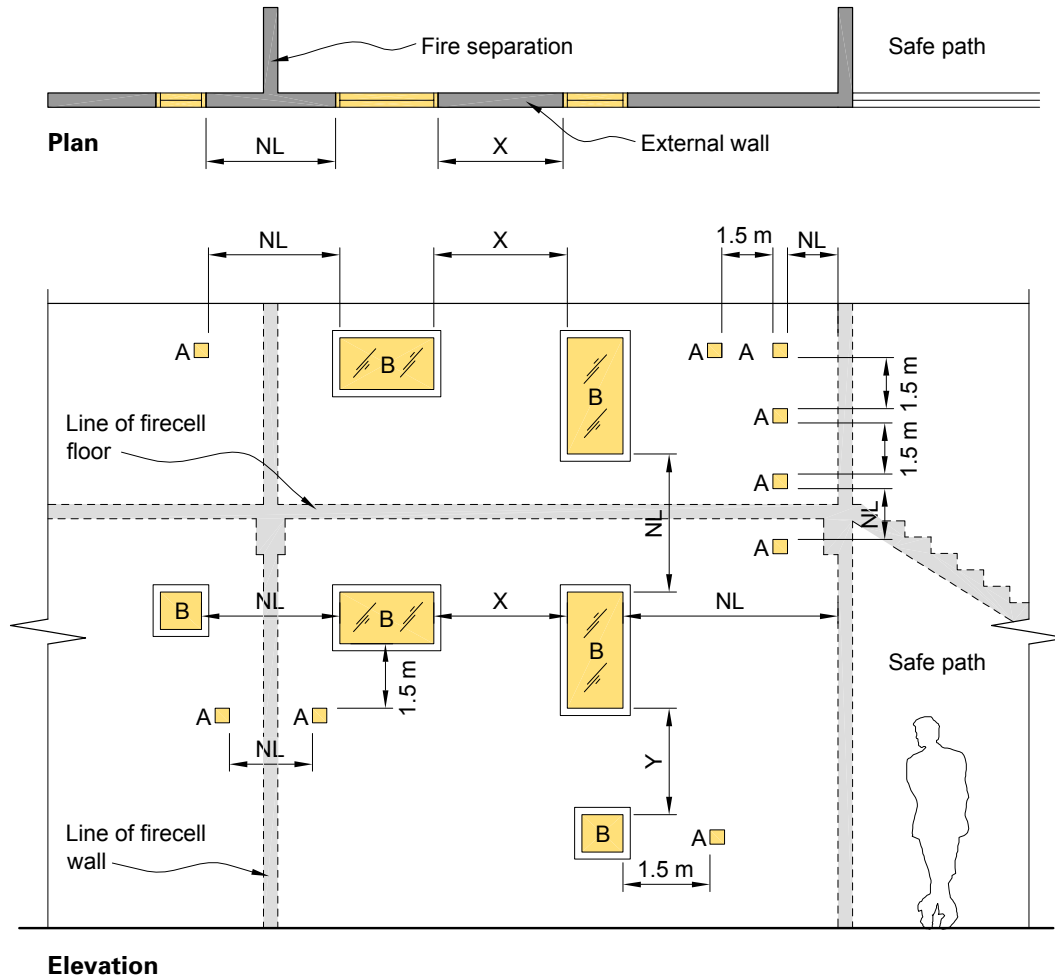

Dimensions shown are minimum distances between Type A unprotected areas and Type B fire resisting glazing

Legend

A □ Type A *unprotected areas* of 0.1 m² maximum

B □ Type B areas of *fire resisting glazing* complying with Table 7.1

NL No limitation on spacing

X Spacing to be no less than the greater of the widths of the two Type B areas being considered

Y Spacing to be no less than the greater of the heights of the two Type B areas being considered

Step 6 From the left hand column select the distance from the *external wall* to the *relevant boundary*. For walls not parallel to the *relevant boundary*, the shortest distance between *relevant boundary* and the closest *unprotected area* in the *external wall* shall be used.

Step 7 From the intersection point of the column chosen in Step 4 and the row chosen in Step 5, read the permitted percentage of *unprotected area*. If the intersection point falls within the shaded area, the permitted *unprotected area* is 100%.

Step 8 Where the *firecell* is sprinklered, apply the increases permitted by Paragraph 7.3.12.

Step 9 Identify the largest single *unprotected area* and treat it as an enclosing rectangle on its own (with 100% *unprotected area*). Check from Table 7.2 that the minimum permitted distance from the *boundary* to this *unprotected area* is no greater than used in Steps 5 and 8 above.

COMMENT:

1. The enclosing rectangle method assumes that *unprotected areas* will be fairly uniformly distributed openings over the total *external wall* of the *firecell*. Step 9 is a safety check to deal with the situation where a large *unprotected area* is concentrated in a single location. Heat radiation in most cases is more intense from a single opening than from several openings with the same total area.
2. Table 7.2 is based on the assumption that there is a limit to the area of *firecell* subject to the full *fire intensity* at any one time. Therefore, as stated in Note 2 to the table, the maximum rectangle width needing to be considered is either 20 m or 30 m depending on *FHC* and rectangle height.

7.5.4 The table may also be used to determine the required distance from the *relevant boundary* where the percentage of *unprotected area* has previously been determined. After Step 4 select the appropriate percentage (under the rectangle width column) and read the permitted distance to the *relevant boundary* from the left hand column of the table.

7.5.5 Where Table 7.2 does not contain the exact measurements for the *firecell* being considered, use the next highest value (for rectangle height, width or *boundary* distance).

Alternatively, the permitted percentage *unprotected area* may be linearly interpolated between enclosing rectangle widths and heights, and between distances to the *relevant boundary*.

COMMENT:

1. In most cases the differences achieved by interpolation are so small that taking the next highest value in the table will usually be satisfactory.
2. Rectangle heights greater than 9.0 m require specific design.

Advantages of additional firecells

7.5.6 Figure 7.6 illustrates how for a given percentage of *unprotected area* in an *external wall*, the acceptable distance between wall and *relevant boundary* may be reduced by introducing additional *firecells*. Alternatively, the introduction of additional *firecells* allows an increase in *unprotected area* for a given distance to the *relevant boundary*.

COMMENT:

In most situations each floor of a multi-floor *building* is required to be a *fire separation*. Where this is not essential (see Paragraph 6.14.1 for exceptions), there may still be advantages close to a *boundary* in having the space on each floor level as a separate *firecell*. The enclosing rectangle is further reduced by subdividing each floor level into separate *firecells*.

Exceptions for SH, SA and SR buildings

7.5.7 When using Method 2, Enclosing Rectangles, for *household units of purpose groups* SH and SR, and accommodation units in *purpose group* SA, it is permissible to apply the method separately at each full floor level of the *firecell* (see Figure 7.7). An upper floor is considered a full floor if the only opening connecting upper and lower levels is limited to a *stairway* access.

Figure 7.5: Method 2 – Enclosing Rectangles (Unprotected Areas)
Paragraph 7.5.3

Rectangle construction

Diagram A, B and C demonstrate how, for a given *external wall* of a single *firecell*, dimensions of the enclosing rectangle (indicated by the rectangle diagonals) vary according to the extent and location of *fire rated construction*. The essential requirement is for the rectangle to enclose all *unprotected areas*. This means that such things as an isolated window or door or other non-*fire* rated part of the wall can significantly alter the rectangle dimensions and may include part of the *fire rated* wall.

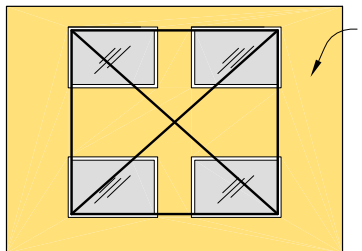

Diagram A

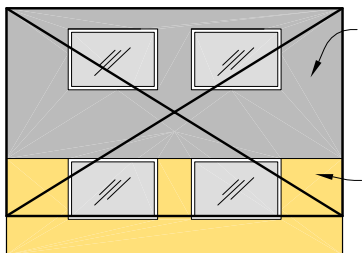

Diagram B

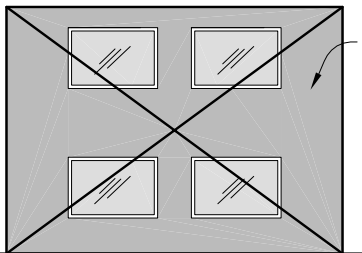





Diagram C

Legend

-  *External wall* with less than the required *FRR* (includes zero *FRR*)
-  *External wall* with required *FRR*
-  Openings or windows
-  Rectangle containing diagonals is the 'enclosing rectangle' for calculations

Note:

In this example it is assumed that the *external wall* is parallel to the *relevant boundary*. Where the wall is not parallel to the boundary, the enclosing rectangle is projected onto a reference plane, at right angles to that plane, (see Paragraph 7.6.4 and Figure 7.8) and the width dimension for applying Table 7.2 is reduced.

Figure 7.6: Method 2 – Enclosing Rectangles (Effect of Firecells on Distance from Boundary)
Paragraphs 7.5.3 and 7.5.6

The number of *firecells* into which a *building* is divided has a considerable effect on the distance permitted between *external walls* and the *relevant boundary*, as is explained in the following examples.

The *building* is in *purpose group* WM with a *FHC* of 3. For Example 1 it is a single *firecell* with an *intermediate floor* having an open *stairway* at one end. Each *unprotected area* (shown as windows or doors) is 1 m x 2 m. The remainder of the wall is *fire rated*.

For Example 2 the *building* is divided into three *firecells* by fully *fire separating* the two floor levels and the *stairway*.

In both examples the shaded portion represents the *fire rated wall area* of the *firecell* being considered, and the enclosing rectangle is represented by the rectangle diagonals.

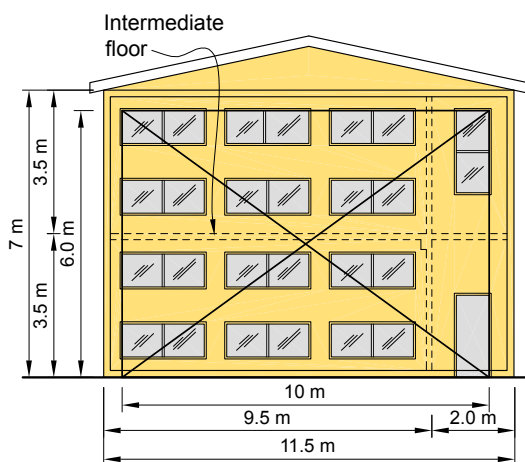

Example 1 - Elevation single firecell

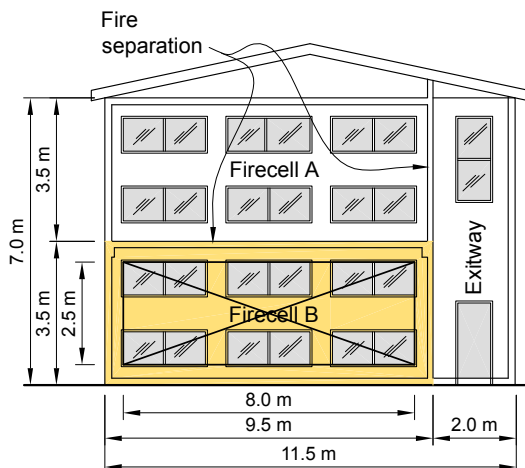

Example 2 - Elevation three firecells

Example 1

1. The enclosing rectangle is 6.0 m high by 10 m wide = 60 m²
2. The total unprotected area (14 openings of 2.0 m²) = 28 m² which is 28/60 x 100 = 46.7% of the enclosing rectangle.
3. From Table 7.2/5 (for an enclosing rectangle height of 6.0 m), with FHC 3 and enclosing rectangle width of 10 m, the minimum distance from the boundary for 46.7% unprotected area is between 6.0 m and 7.0 m. By interpolation the exact distance is 6.63 m.

Example 2

The calculation for the distance to the boundary need be done only for the most critical firecell. In this case the upper and lower firecells A and B are the same. (Note that the exitway is automatically FHC 1.)

1. The enclosing rectangle is 2.5 m high by 8 m wide = 20 m².
2. The total unprotected area is 12 m² which is 12/20 x 100 = 60% of the enclosing rectangle.
3. The enclosing rectangle height of 2.5 m is midway between the 2.0 m from Table 7.2/2 and the 3.0 m from Table 7.2/3.
4. For FHC 3 and enclosing rectangle width 8.0 m having 60% unprotected area:
 - a) The minimum distance to the boundary is between 3.0 m and 3.5 m (interpolated to 3.2 m) from Table 7.2/2.
 - b) The minimum distance to the boundary is between 4.0 m and 5.0 m (interpolated to 4.44 m) from Table 7.2/3.
 - c) Interpolating for rectangle height, the required distance is halfway between that derived from Table 7.2/2 and Table 7.2/3 and is (3.2 + 4.44)/2 = 3.82 m from the relevant boundary.
5. Check the largest opening (1.0 m high x 2.0 m wide) as 100% unprotected area. From Table 7.2/1 minimum distance to boundary 1.2 m therefore OK.

Note:

1. In the above diagrams it is assumed that the *relevant boundary* is parallel with the wall face.
2. Because the wall construction in these examples is *fire rated*, the gable end does not affect the enclosing rectangle size. If the gable end should contain *unprotected areas* the height of the enclosing rectangle would be determined as described in Paragraph 7.5.10.

Figure 7.7: Purpose Groups SH, SA and SR – Application of Enclosing Rectangles Method
Paragraphs 7.5.7 and 7.5.9

This example shows two *household units* in *purpose group SR*. Each section of wall per storey indicated by 'X' (the rectangle diagonals) may be treated individually when using the enclosing rectangles method to determine the permitted *unprotected area* with respect to distance from the *relevant boundary*.

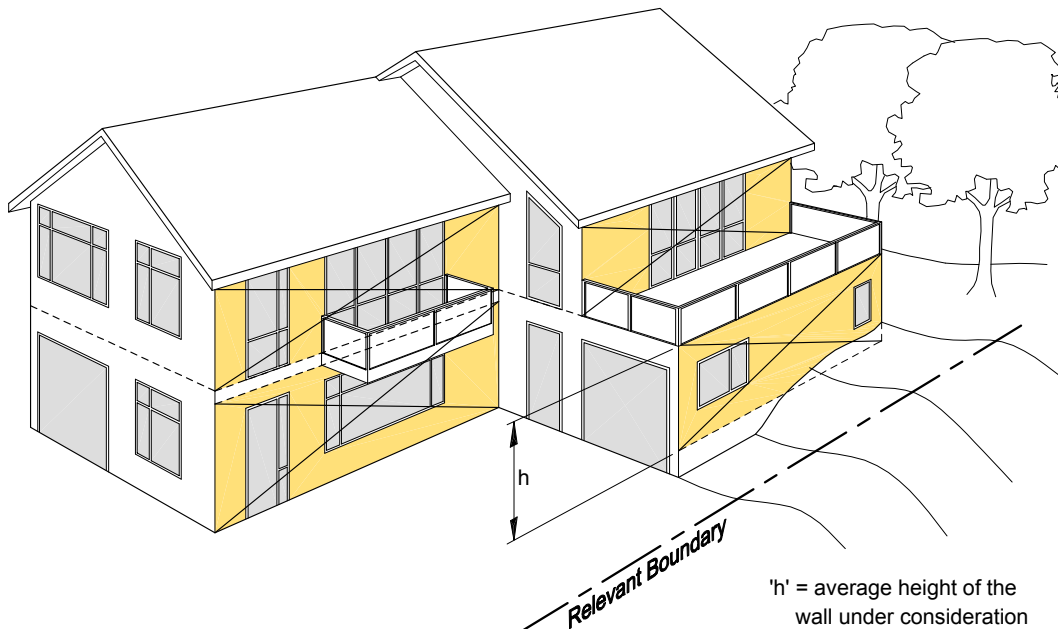

Notes:

1. In this example the roof facing the *relevant boundary*, slopes at greater than 30° to the vertical, and need not be considered as part of the *external wall* when determining the height of the enclosing rectangle. (See definition of *external wall*.)
2. If the gable end of the *building* was being considered, the height of the enclosing rectangle for the upper floor would be the average height from floor level to ridge line.

7.5.8 This approach allows an increased *unprotected area* because the height of the enclosing rectangle is reduced. Where the *external wall* is stepped back at any level, the permitted *unprotected area* is again increased due to the greater distance from the *relevant boundary*.

Buildings on sloping sites and buildings of irregular height

7.5.9 For *purpose groups SH, SA and SR*, the enclosing rectangle width is taken as the full width of the *firecell* wall being considered, and the rectangle height is taken as the height

between successive full floors. Where, due to the *building site slope* or the *building shape*, the height of the enclosing rectangle is not constant (see Figure 7.7), the height shall be taken as the average height across the width of the wall being considered.

7.5.10 For *purpose groups* other than SH, SA and SR, the enclosing rectangle height may be taken as the average *firecell* height across the width of that enclosing rectangle.

7.6 Method 3 – Enclosing Rectangles – Irregular Buildings and Non-parallel Boundaries

7.6.1 This method applies where the *building* is of irregular shape or the intersection angle between the *external wall* and *relevant boundary* is between 10° and 80°.

7.6.2 The method (see Figure 7.8) is a variation of Method 2 and evaluates the enclosing rectangle on an assumed reference plane.

COMMENT:

Greatest advantage is obtained by locating the reference plane to achieve the maximum separation distance over the part of the wall having the largest *unprotected area*. In general, the most convenient location of the reference plane will be parallel to the *relevant boundary*.

7.6.3 The reference plane shall be vertical, touch at least one point on the *external wall*, and not cross the *relevant boundary* within the length of the *firecell*. The plane must not pass through the *firecell*, but may pass through projections such as balconies or copings.

7.6.4 The enclosing rectangle is determined by projecting the *unprotected areas* onto the reference plane at right angles to the plane, and the distance to the *relevant boundary* used in the calculations shall be the shortest distance between that *boundary* and the closest projected *unprotected area* on the reference plane.

Unprotected areas which are more than 80° to the reference plane are not included.

7.6.5 Once the enclosing rectangle is determined, follow the Steps 3 to 9 in Paragraph 7.5.3.

7.7 Method 4 – Return Walls and Wing Walls

Other property or same property

7.7.1 For Method 4 there are two tables. Table 7.3 applies to the requirements for separation from the *relevant boundary* with *other property*. Table 7.4 applies to the separation requirements on the same property where either one or both *firecells* being considered

contains a sleeping *purpose group* or is a *safe path*. When using Table 7.4, separation distances are measured between *unprotected areas* in the *firecells* being considered, and the *notional boundary* coinciding with the *external wall* of the other *firecell*.

7.7.2 For intersection angles (see Paragraph 7.3.4) from 80° to 90°, minimum separation distances can be read directly from the tables. For intersection angles between 90° and 135° (see Figure 7.9) the values read from tables can be reduced as described in Paragraph 7.7.7.

Return walls

7.7.3 Return wall requirements are determined from the formula $L_r = D_B - D_S$ where:

L_r is the return wall length,

D_B is the minimum permitted distance between *unprotected areas*, in the *external wall* being considered, and the *relevant boundary*,

D_S is the shortest distance between the *external wall* being considered and the *relevant boundary*

L_r , D_B and D_S are measured at right angles to the *relevant boundary* (see Figure 7.9).

Wing walls

7.7.4 Wing wall lengths are determined from the formula:

$$L_w = \frac{L_B \times L_r}{D_B} \quad \text{where:}$$

L_w is the wing wall length,

L_B is the wing wall length (from Table 7.3 or 7.4) if that wall is located on the *relevant boundary*,

L_r is the alternative return wall length as determined in Paragraph 7.7.3,

D_B is minimum separation distance between *unprotected areas*, and the *relevant boundary* in the *external wall* being considered, if a return wall is used. (Given in Table 7.3 or 7.4.)

Figure 7.8: Method 3 – Enclosing Rectangles (Irregular Shaped Buildings and Non-parallel Boundaries)
Paragraph 7.6.2 and Figure 7.5

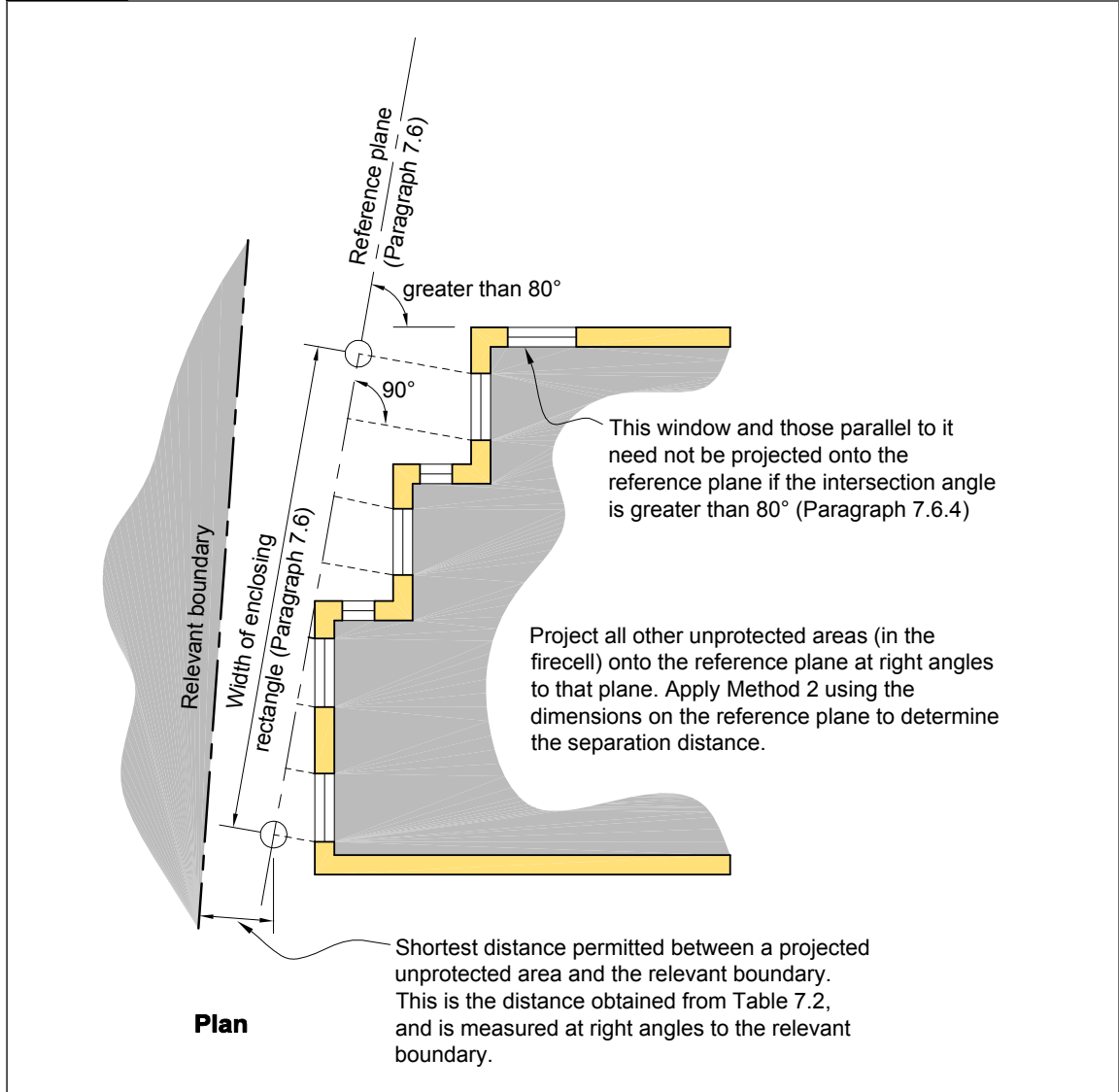

COMMENT:
It is more economical to use a return wall in the firecell of fire origin than to use a wing wall as a shield between that firecell and the property being protected.

Using Table 7.3 and Table 7.4

7.7.5 The calculation steps are:

Step 1 Determine the shortest distance D_s between the relevant boundary and the nearest part of the external wall of the firecell being considered. (See Figure 7.9.)

Step 2 On the external wall draw a rectangle enclosing all the unprotected areas located within a distance of 20 metres measured at right angles to the relevant boundary. The height of this rectangle is the equivalent opening height h_{eq} .

COMMENT:
It is assumed that unprotected areas more than 20 m from the relevant boundary do not pose a radiation threat.

Step 3 Sum the individual unprotected areas within the enclosing rectangle. This is the equivalent opening area A_o .

Figure 7.9: Method 4 – Return Walls on External Walls having an Intersection Angle of Between 80° and 135° with the Relevant Boundary or Notional Boundary
Paragraphs 7.7.2, 7.7.3 and 7.7.5

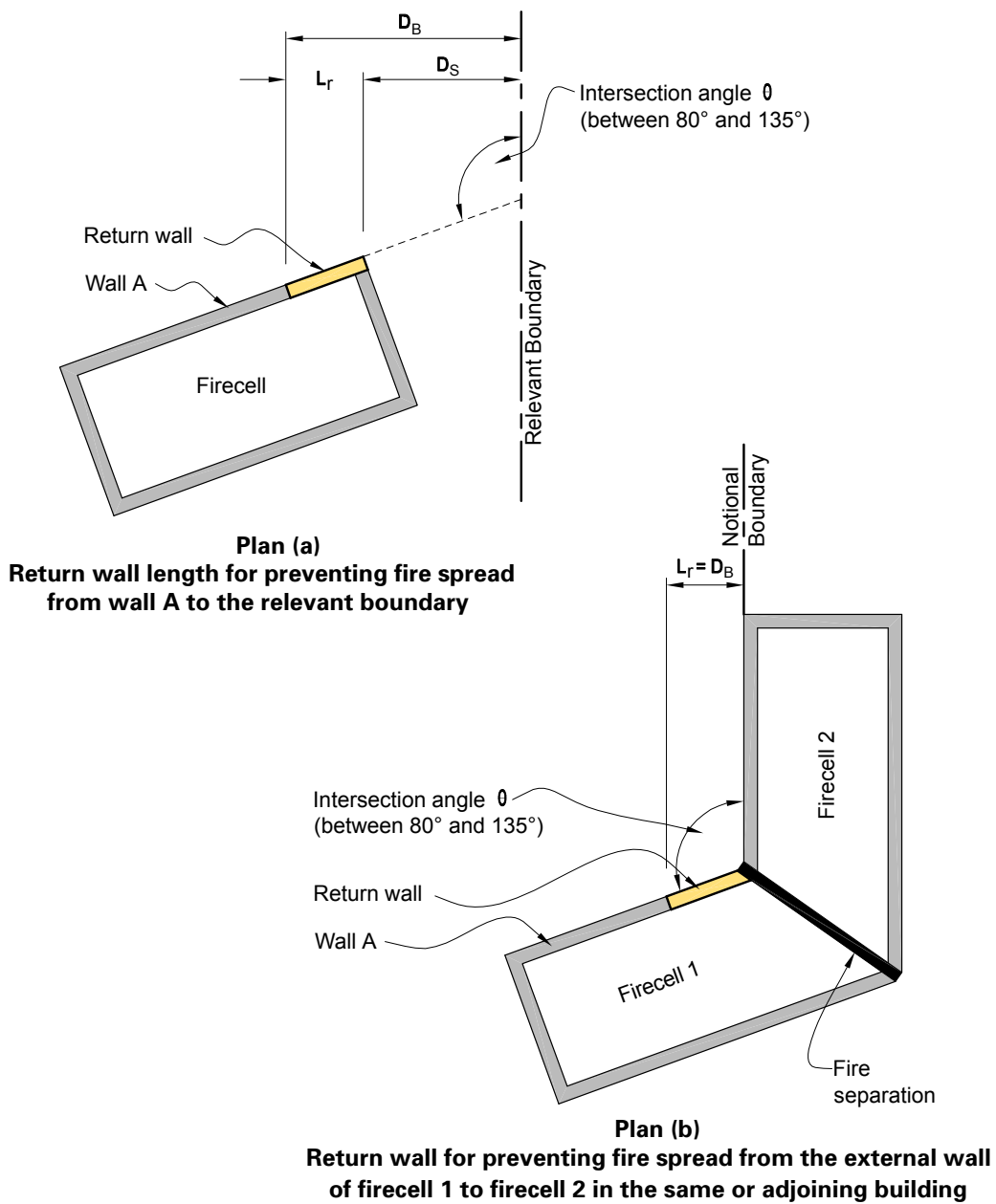

Key

- D_s = The shortest distance between the *external wall* being considered and the *relevant boundary*.
- D_B = Minimum permitted distance between *unprotected areas* in wall A and the *relevant boundary* as determined from Table 7.3 for plan (a), or the *notional boundary* as determined from Table 7.4 for plan (b).
- L_r = The required return wall length measured at right angles to the *relevant boundary* or *notional boundary* as applicable.
- θ = Intersection angle (degrees) as described in Paragraph 7.3.4

Step 4 Divide A_o by h_{eq} to obtain the equivalent opening width W_{eq} .

COMMENT:

Table 7.3 and Table 7.4 are based on the assumption that the equivalent opening area is located at the end of the wall nearest the *relevant boundary*. This is a conservative, but safe, simplification for determining the most severe thermal radiation likely to be emitted from a *fire* within the *firecell*.

Step 5 In the left hand column of Table 7.3 or Table 7.4 (as appropriate), select the panel for *FHC* of the *firecell* being considered.

Step 6 Choose either the return wall or wing wall section of the table (according to the construction method proposed), and from the panel selected in Step 5, identify the row for the equivalent opening height h_{eq} .

Step 7 From the top row of the table, select the column for the equivalent opening width W_{eq} .

Step 8 At the intersection point of the row (from Step 6) and the column (from Step 7), read off the separation distance D_B for return walls, or the length L_B for wing walls.

Step 9 For return walls, determine the return wall length L_r from the formula $L_r = D_B - D_S$. For wing walls, determine the wing wall length from the formula:

$$L_w = \frac{L_B \times L_r}{D_B}$$

For a *firecell* on the *relevant boundary* $D_S = 0$ and therefore for a return wall $L_r = D_B$ and for a wing wall $L_w = L_B$. If D_B is equal to or greater than D_S , the formula produces a zero or negative result and there is no requirement for a return wall or wing wall.

Sprinklered firecells

7.7.6 Using Method 4, where the *firecell* is sprinklered the values of D_B and L_B , as derived from Table 7.3 or Table 7.4, may be halved.

Intersection angles of between 90° and 135°

7.7.7 As the intersection angle increases beyond 90°, the return wall length and wing wall length can be reduced linearly to give shorter return walls or wing walls by applying the formula:

$$L_r = \left(\frac{135 - \theta}{45} \right) \times (D_B - D_S), \text{ or}$$

$$L_w = \left(\frac{135 - \theta}{45} \right) \times \left(\frac{L_B \times L_r}{D_B} \right)$$

where θ is the intersection angle. The reduction in the values of D_B and L_B for sprinklers (see Paragraph 7.7.6) may be applied.

Note that the formula does not apply to intersection angles of less than 90°.

COMMENT:

As an example of using the reduction formula, if the intersection angle is 112° (which is halfway between 90° and 135°) the value taken from Table 7.3 or Table 7.4 may be halved.

7.8 Horizontal Fire Spread from Roofs, Floors and Open Sided Buildings

7.8.1 Where the roof of an unsprinklered *firecell* with a *fire hazard category* of 3 or greater is within 1.0 m of a *relevant boundary*, horizontal *fire* spread shall be resisted by either:

- a) *Fire* rating (for *fire* exposure from below) that part of the roof within 1.0 m of the *relevant boundary*. The *FRR* shall be based on the *S rating* for the *firecell*, except that *insulation* is not required, or
- b) Extending the wall, being a *fire separation* along or adjacent to the *relevant boundary*, no less than 450 mm above the roof to form a parapet.

COMMENT:

Sprinklered *firecells* within 1.0 m of a *relevant boundary* are not required to have *fire* rated roofs or walls extended to form parapets.

Parapets for roof car parking or storage

7.8.2 Where cars are parked or *combustible* materials are stored on an area of roof within 1.5 m of a *relevant boundary*, but the conditions of Paragraph 7.9.16 (for an adjacent higher wall) do not apply, a parapet shall be *constructed*. The parapet shall extend no less than 1.5 m above roof level for cars, or above the top of the stored materials, on the side of the *relevant boundary*. The parapet shall have an *FRR* of no less than 30/30/30 for car parking and stored materials with a *fire hazard category* 1 or 2, and 60/60/60 for stored materials with a *fire hazard category* 3 or 4.

Roof projections

7.8.3 Where the *external wall* is required to have a *FRR*, the eaves projection shall be *constructed* with the same *FRR* as the *external wall*. Alternatively, the *external wall* shall be extended behind the eaves projection to the underside of the roof and the eaves need not be *fire* rated.

7.8.4 Where the *external wall* is not required to have a *FRR*, roof eaves projecting from that wall need not be rated provided that no part of the eaves *construction* is closer than 650 mm to the *relevant boundary*.

7.8.5 Where the *external wall*, on its own, is not required to have a *FRR*, but roof eaves extend to within 650 mm of the *relevant boundary*, the total eaves *construction* and the *external wall* from which they project shall have a *FRR*. For *purpose groups* SH and SR that *FRR* shall be 30/30/30. For other *purpose groups* the *FRR* shall be based on the *S rating* for the *firecell* protected by the *external wall*.

COMMENT:

Eaves *construction* includes the gutter and spouting and any other projections from the eaves, although guttering and spouting need not be *fire* rated.

Amend 7
Nov 2008

Floor projections

7.8.6 Where a floor projects beyond the face of an *external wall* to which a *S rating* applies, or where any part of the projection is closer than 1.0 m to the *relevant boundary*, the floor projection shall have the same *FRR* as the

floor, and exposed exterior faces of the projection shall satisfy the same *surface finish* requirements as the *external wall* cladding system (see Table 7.5).

Balconies

7.8.7 When an *external wall* has balconies or similar *constructions* which cause the permitted *unprotected area* to be exceeded, another wall shall be *constructed* further in from the face of the *building*, and shall satisfy all the requirements for an *external wall*.

COMMENT:

1. In this situation, the distance to the *relevant boundary* is measured from the "inner" *external wall*.
2. Where the balcony is a *safe path*, the *construction* and ventilation requirements of Paragraph 3.14.7 apply.

Open sided buildings

7.8.8 An open sided *building* may be either a detached *building* or be connected to another *building* (see Figure 7.10). For the open sided *building* to be deemed "detached", the horizontal distance between the other *building* and the roof of the open sided *building* shall be no less than:

- a) 1.0 m for a roof area exceeding 40 m², and
- b) 0.3 m for a roof area no greater than 40 m².

7.8.9 A *building* having only a single floor level may be *constructed* with walls and roof having 100% *unprotected area* provided that:

- a) At least two sides of the perimeter wall are completely open to the environment, and
- b) If attached to another *building*, both *buildings* are under the control of the same occupancy, and
- c) For unlimited roof plan areas:
 - i) the *building* contents under the roof have a *FHC* of no greater than 2, and
 - ii) no part of the roof is closer than 1.0 m to a *relevant boundary*, and
- d) For roof plan areas of no greater than 40 m²:
 - i) the contents under the roof have a *FHC* of no greater than 1, and
 - ii) no part of the roof is closer than 0.3 m to a *relevant boundary*.

Figure 7.10: Open Sided Buildings – Separation Distances and FRR Requirements
Paragraph 7.8.8

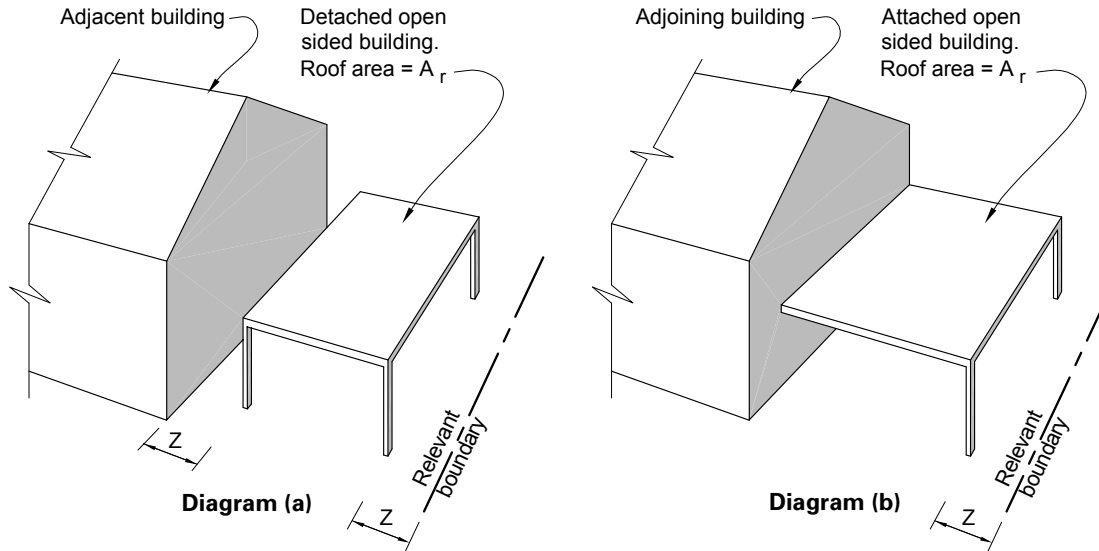

When A_r is no greater than 40 m^2 , 'Z' shall be no less than 0.3 m.
When A_r exceeds 40 m^2 , 'Z' shall be no less than 1.0 m.

Separation distances for non-fire rated construction

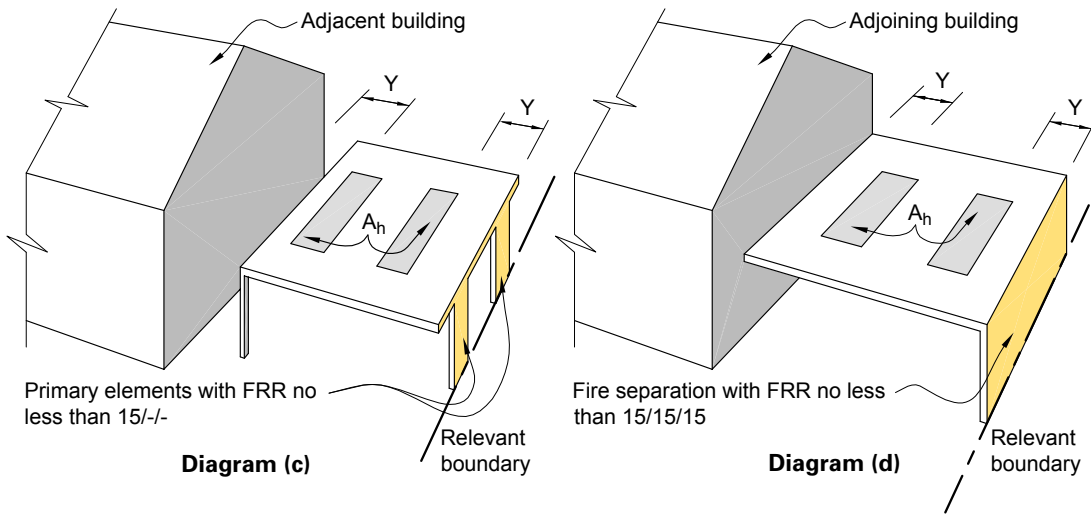

A_h = total venting area no less than 15 % of roof area.
Remainder of roof to satisfy Table 7.5.
Distance 'Y' no less than 1.0 m.

Fire rating requirements on or near the boundary

Notes:

1. This figure applies only to single storey open sided buildings.
2. In all cases at least two sides of the perimeter wall shall be completely open to the environment.
3. The FHC of the open sided building contents must not exceed 1 for roof areas up to 40 m^2 and no less than 0.3 m from a relevant boundary or 2 for buildings no less than 1.0 m from a relevant boundary.

7.8.10 For an open sided *building* located closer to a *relevant boundary* than the distances allowed in Paragraphs 7.8.9 c) and d), the following additional requirements shall be met:

- a) The roof cladding shall satisfy the rate of heat release requirements of Table 7.5 except that no less than 15% of the roof area shall be *constructed* to be self venting (by opening or melting rapidly) in the event of a *fire* occurring below. No self venting area shall be located closer than 1.0 m to any attached *building*, *sleeping purpose group*, *other property* or *relevant boundary*, and
- b) If the open sided *building* is detached, the *primary elements* supporting the roof adjacent to the *relevant boundary* shall have a *FRR* of no less than 15/-/, or
- c) If the open sided *building* is attached to another *building*, a wall shall be provided adjacent to the *relevant boundary*. The wall shall have no *unprotected areas* and shall be rated from both sides with a *FRR* of no less than 15/15/15.

COMMENT:

Examples of open sided *buildings* having a roof area exceeding 40 m² are canopies over forecourt areas at service stations, while those with roof areas of less than 40 m² would be structures such as carports associated with detached dwellings.

7.9 Vertical Fire Spread

Roofs

7.9.1 *Sleeping purpose groups*, *other property* and external *exitways* shall be protected against vertical *fire* spread from roofs.

7.9.2 Protection against *fire* spread shall be achieved using one or more of the following methods as described in Paragraphs 7.9.3 to 7.9.19:

- a) Separation by distance.
- b) Providing *fire separation* by use of parapets.
- c) *Fire* rating the adjoining *external wall*.
- d) *Fire* rating all or part of the roof against the threat of *fire* from the underside.
- e) Installing sprinklers in the *firecell* below the roof.

External exitways over roofs

7.9.3 Subject to Paragraph 3.14.3, when an external *exitway* crosses a roof, or is above or adjacent to a roof on the same or another *building*, the roof within 3.0 m of any part of the *exitway*, and all supporting elements, shall have a *FRR* of 60/60/60 or 30/30/30 if the *firecell* below is sprinklered.

Amend 4
Oct 2005

Primary elements

7.9.4 *Primary elements* providing support to an area of *fire* rated roof shall have a *FRR* of no less than that of the roof.

7.9.5 When supporting an unrated roof:

- a) *Primary elements* such as columns or walls which are required to be *fire* rated shall be rated from floor level to the underside of the roof framing members.
- b) Any roof framing members connected to these *fire* rated columns or walls, shall also be rated if their collapse in *fire* would cause the consequential collapse of the rated columns or walls.

Fire spread from an adjacent lower roof

7.9.6 *Fire* spread from a roof close to and lower than an *external wall* shall be avoided by compliance with Paragraph 7.9.7 where *firecells* behind the wall contain:

- a) *Purpose groups* SC, SD, SA, SR, or IE, and are located in the same *building* (as the lower roof), or in an *adjacent building* on the same title, or
- b) Any *purpose group* in an *adjacent building* on *other property*.

7.9.7 Where the distance between any part of an *external wall* and a lower roof is less than 9.0 m vertically or 5.0 m horizontally (see Figure 7.11), protective measures shall be applied either to the roof as in Paragraph 7.9.8, or to the wall as in Paragraph 7.9.9.

7.9.8 Roof protection shall be provided by:

- a) Installation of sprinklers in the *firecell* below the roof, or
- b) *Constructing* that part of the roof within 5.0 m horizontally of the wall, with a *FRR* derived from the *S rating* of the *firecell* below the roof.

External fire spread between different levels of the same building

7.9.10 Except where *firecells* are sprinklered, *unprotected areas* in *external walls* shall be protected against vertical *fire* spread where any of the following conditions occur:

- a) *Firecells* containing *purpose groups* SC, SD, SA or IE have an *escape height* of 4.0 m or more, or
- b) *Firecells* containing *purpose group* CM have an *escape height* of 7.0 m or more, or
- c) *Firecells* containing *purpose group* SR (except where sub-paragraph d) applies) have an *escape height* of 10 m or more, or
- d) *Firecells* containing *other property* are located one above the other.

Amend 4
Oct 2005

7.9.9 *External wall* protection above an adjacent lower roof shall be provided by *constructing* the critical part of the wall (closer to the roof than 9.0 m vertically or 5.0 m horizontally) with a *FRR* of no less than required in Paragraph 7.9.8 b).

Figure 7.11: External Walls and Roof, Vertical Fire Spread
Paragraph 7.9.7 and Figure 7.1

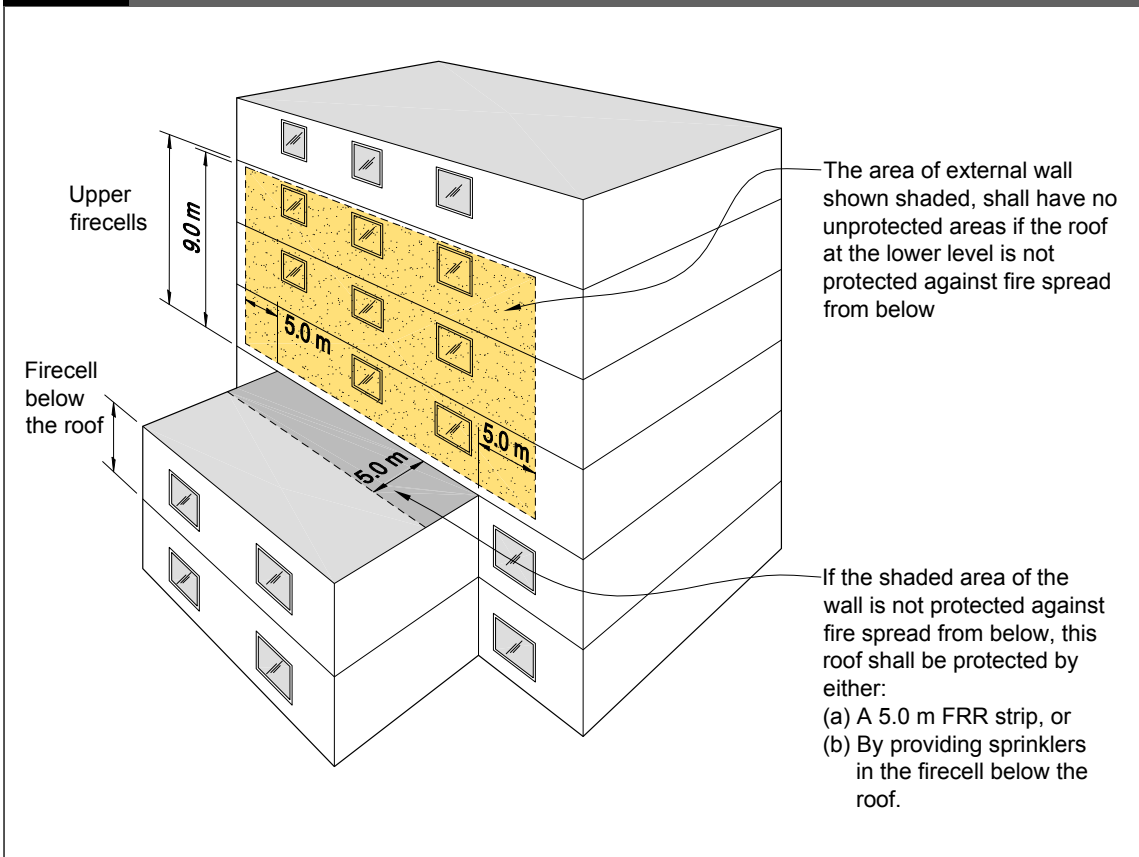

COMMENT:

For *purpose group* SR, whether item c) or d) applies depends on whether all *firecells* are under a single *ownership*, or each *firecell* is *other property* with separate title.

7.9.11 Where the conditions of Paragraph 7.9.10 occur, *unprotected areas* in the *external walls* of the *firecells* shall be separated by no less than:

- a) 1.5 m where any parts of the *unprotected areas* are vertically aligned above one another, or
- b) 900 mm where the *unprotected areas* on one level are horizontally offset from those on the other level (see Comment below Paragraph 7.9.13).

7.9.12 Spandrels may be omitted where an apron, projecting no less than 0.6 m is *constructed* (see Figure 7.2). The following table provides acceptable combinations of apron projection 'P' and spandrel height 'H'.

Apron projection		Spandrel height
P		H
(m)		(m)
0.0		1.5
0.3		1.0
0.45		0.5
0.6		0.0

7.9.13 Aprons shall extend horizontally beyond the outer corners of the *unprotected area* by no less than the apron projection distance 'P'. Aprons and spandrels shall have a *FRR* of no less than that of the floor separating the upper and lower *firecells*. Spandrels shall be rated from both sides, aprons need be rated only from the underside.

COMMENT:

The arrangement of windows in each *external wall* is crucial to the prevention of spread of *fire* from floor to floor vertically due to flame projection. The requirements of Paragraph 7.9.11 allow a chess board arrangement, vertical spacing of 1.5 m, or aprons. See also Paragraph 7.10 for application of *FRRs* to *external walls*.

7.9.14 Where there is a gap between an *external wall* and a *fire separation* which together enclose a *firecell*, the space between the *fire separation* and the *external wall* shall be no greater than 50 mm and be *fire stopped* (see Figure 6.11).

COMMENT:

This situation normally occurs in curtain wall *construction*.

7.9.15 Eaves and floors overhanging an *external wall* shall be protected as required by Paragraphs 7.8.3 to 7.8.5.

Roof car parking and storage

7.9.16 Where a roof used for car parking or the storage of *combustible* materials is within 1.5 m of a higher *external wall* and the *building* above contains sleeping *purpose groups*, the protective measures of Paragraph 7.9.9 shall apply. However, the 9.0 m vertical and 5.0 m horizontal distances may be reduced to 3.0 m and 1.5 m respectively.

7.9.17 Vertical distances shall be measured:

- a) For car parking, from the *building* roof level, and
- b) For stored materials, from the top of those materials. (See Paragraph 7.8.2 for parapet protection against horizontal *fire* spread.)

External thermal insulation on walls in multi-storey buildings

7.9.18 *Buildings* of three or more floors with an *external wall* cladding system incorporating an externally applied *combustible* insulant, are required to have horizontal barriers installed in the cladding system at intervals of not more than two floors. For framed wall systems a barrier shall be *constructed* within the framed cavity, and a *fire stop* barrier shall be *constructed* at the same level within the cladding system. An acceptable detail for barriers is shown in Figure 7.12. This requirement does not apply to *combustible* insulant positioned between studs and dwangs in a conventional framed wall system.

Figure 7.12: Barriers to Vertical Fire Spread in Foamed Plastics External Insulation Systems
Paragraph 7.9.18

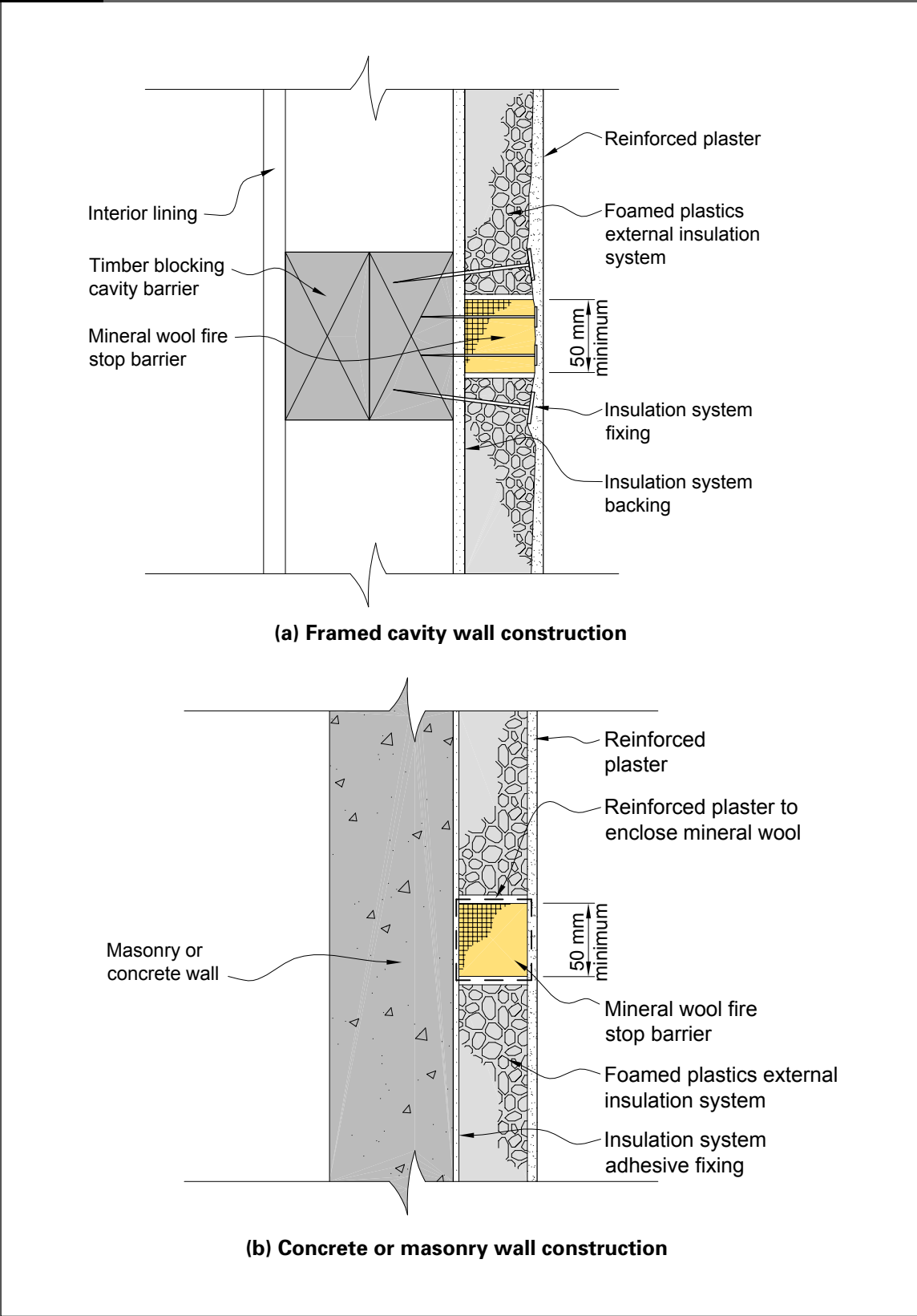

7.9.19 Paragraph 7.9.18 applies where the floors are *fire separations* between *firecells*. It does not apply within *household units of purpose groups SH and SR* or to any *external wall* satisfying the test requirements of Paragraph 7.11.2 b).

COMMENT:

1. Horizontal *fire stop* barriers are needed to prevent progressive involvement of insulants in *fire* by restricting hot gases or flames from travelling upwards within the insulation layer. In practice it may be necessary to specify movement joints to control cracking of the render or surface coating, and these may be conveniently incorporated within barriers. Further guidance and suitable *fire barrier* details may be found in BRE Defect Action Sheet DAS 131 dated May 1989 with additional information provided in BRE Report "Fire performance of external thermal insulation for walls in multi-storey buildings", 1988.
2. *Combustible* insulants may include expanded polystyrene (EPS), polyisocyanurate, or polyurethane. The insulants may be covered on the exterior side with a sheet material or with a thin rendered cementitious or polymeric coating.

7.10 FRRs of External Walls

7.10.1 *Building elements* which are part of an *external wall* shall be *fire rated* as required by Paragraphs 5.7.5 and 5.7.6.

7.10.2 Except as provided for in Paragraphs 7.10.7 to 7.10.9, any part of an *external wall* enclosing a *firecell* and not permitted to be an *unprotected area*, shall have a rating based on the higher of the *F* or *S rating* applicable to that *firecell*.

7.10.3 When the *unprotected area* of an *external wall* is permitted to be 100%, but the *primary elements* in the line of that wall are required to be *fire rated*, the rating of those *primary elements* shall be based on no less than the *F rating*.

COMMENT:

Primary elements are required to be *fire rated* in *buildings* with an *escape height* of greater than 25 m, and where they support, or are an integral part of, other *fire rated building elements*. See Paragraphs 5.3, 5.9, 7.9.4 and 7.9.5.

Return walls and wing walls

7.10.4 Return walls and wing walls shall be rated as for *external walls* (see Paragraphs 5.7.5 and 5.7.6).

Fire resistance ratings shall be no less than required for the *fire separations* of the *firecell*, or for the *primary elements*, whichever is the greater.

COMMENT:

Fire rating of external walls on both sides equally is required by Paragraph 5.7.6 where:

- Walls are within 1.0 m of a *relevant boundary*, or
- The *firecell* contains *purpose groups SC, SD or SA* with one or more floor levels above their *final exit* or *SR* with two or more levels above the *final exit*, or
- The *building height* is greater than 10 m.

Small buildings

7.10.5 An *S rating* need not be applied to single floor small *buildings* where:

- a) The *FHC* is no greater than 1, and
- b) The floor area is no greater than 40 m², and
- c) It does not contain a sleeping *purpose group*.

However, a *FRR* of no less than 30/30/30 shall apply to any *external wall* less than 1.0 m from the *relevant boundary*.

COMMENT:

This paragraph is intended to apply to garages, sheds and similar *buildings*, not to sleeping accommodation such as granny flats.

It is considered that *other property* is adequately protected for such *buildings* by providing a simple *FRR* to the wall.

Amend 5
Oct 2005

Amend 4
Oct 2005

Amend 4
Oct 2005

Amend 4
Oct 2005

Amend 4
Oct 2005

Purpose groups SH and SR

Amend 4
Oct 2005

7.10.6 For detached dwellings (*purpose group* SH), in which the *household unit firecell* contains no more than three floor levels, the *external walls* are required to be *fire rated* only if less than 1.0 m from the *relevant boundary*. In that case the *external wall* shall have a *FRR* of no less than 30/30/30. The same provisions apply to *multi-unit dwellings* (*purpose group* SR), provided that adjacent *household unit firecells* are located only at ground level and are not one above another.

Amend 4
Oct 2005

7.10.7 Where a *building* contains *purpose group* SR with no more than two household units located vertically one above the other, and with no more than two floor levels in each, parts of the *external wall* not permitted to be *unprotected areas* shall have a *FRR* of no less than 30/30/30.

Amend 4
Oct 2005
Amend 5
Oct 2005

7.10.8 For all SH and SR *buildings* not described in Paragraphs 7.10.6 and 7.10.7, *external walls* not permitted to be *unprotected areas* shall have a *FRR* derived from the *S rating*.

7.11 Exterior Surface Finishes

Roofs

7.11.1 For roofs in *purpose groups* SC and SD, *combustible* materials shall not be used as an external cladding except that, a *combustible* surfacing which is in close contact with and adhered to, either a *non-combustible* substrate or timber no less than 18 mm thick, is acceptable.

External walls

7.11.2 The peak rate of heat release and the total heat released from the *external wall* cladding system, as determined in accordance with Paragraph C9.1, shall not exceed the limits given in Table 7.5. These requirements do not apply where:

- a) *Surface finishes* are no more than 1.0 mm in thickness and applied directly to a *non-combustible* substrate, or
- b) The entire wall assembly has been tested at full scale in accordance with NFPA 285 and passed the test criteria.

COMMENT:

Other full scale facade test methods may also be acceptable to the *building consent authority*.

Amend 7
Nov 2008

7.11.3 Where a *building* has *firecells* containing different *purpose groups*, the acceptable peak rate of heat release and total heat released (as specified in Table 7.5) of an *external wall* cladding system may have different values provided that:

- a) For each *purpose group* the value is no greater than required by Table 7.5 for the *building height* (not just the height of the *firecell*), and
- b) The value applied to a *firecell* is no greater than required by any *firecells* at a higher level on that wall.

COMMENT:

1. This means that where any *purpose group* requires a Type B performance, all lower floors shall have either a Type B or Type A performance in terms of Table 7.5. Should any *purpose group* require a Type A performance, all floors below shall have a Type A performance.

2. For *external walls* the acceptable properties of *external wall cladding systems* depend on the *purpose group*, the *building height*, presence of sprinklers and the distance from the *relevant boundary*.
3. An *external wall cladding system* includes any applied *surface finish* such as a paint or other coating combined with the substrate material. *Fire tests* should be carried out on samples representative of the finished product as used on the *building*, in order to determine compliance with Table 7.5.
4. While the specific heat release rate of a cladding system must be verified by *standard test* results, the following is an indication of the performance of some types of *construction*.

- *Non-combustible* materials such as concrete, brick, glass and steel meet the Type A and Type B requirements.
- Cellulose fibre-cement products with applied finishes/coatings less than 1.0 mm thick would “typically” meet Type A and Type B requirements.
- Ordinary timber products would “typically” not meet the requirements of Type A or Type B.

Purpose group SH

7.11.4 Buildings of *building height* less than 10 m and containing *purpose group SH* need not comply with Table 7.5 where an *external wall* is more than 1.0 m from the *relevant boundary*.

Amend 5
Oct 2005

Table 7.1: Method 1 – Permitted Areas of Fire Resisting Glazing
Paragraphs 7.3.13, 7.3.14, 7.3.15 b), 7.4.2 and Figure 7.4

Glazing area (m ²)	Minimum distance to relevant boundary (m)					
	Unsprinklered firecells			Sprinklered firecells		
	FHC 1	FHC 2	FHC 3 or 4	FHC 1	FHC 2	FHC 3 or 4
1.0 or less	0.0	0.0	0.0	0.0	0.0	0.0
1.5	0.5	0.7	0.9	0.0	0.0	0.4
2.0	0.6	0.8	1.1	0.0	0.0	0.5
2.5	0.7	0.9	1.2	0.0	0.0	0.5
3.0	0.7	1.0	1.3	0.0	0.0	0.6
3.5	0.8	1.0	1.4	0.0	0.0	0.6
4.0	0.9	1.1	1.5	0.0	0.0	0.7
4.5	0.9	1.2	1.6	0.0	0.0	0.7
5.0	0.9	1.2	1.6	0.0	0.1	0.7
5.5	1.0	1.3	1.7	0.0	0.1	0.8
6.0	1.0	1.3	1.8	0.0	0.2	0.8
6.5	1.1	1.4	1.9	0.0	0.2	0.8
7.0	1.1	1.4	2.0	0.0	0.2	0.9
7.5	1.1	1.4	2.1	0.0	0.3	0.9
8.0	1.2	1.5	2.2	0.0	0.3	1.0
8.5	1.2	1.5	2.3	0.0	0.4	1.0
9.0	1.3	1.6	2.4	0.0	0.4	1.1
9.5	1.3	1.7	2.5	0.0	0.4	1.1
10.0	1.3	1.7	2.6	0.0	0.5	1.2
11.0	1.4	1.9	2.7	0.0	0.5	1.3
12.0	1.4	2.0	2.9	0.0	0.6	1.4
13.0	1.5	2.1	3.1	0.1	0.7	1.5
14.0	1.6	2.2	3.2	0.1	0.7	1.6
15.0	1.7	2.3	3.4	0.2	0.8	1.7

Amend.5
Oct 2005

Rectangle height 1 m

Table 7.2/1: Method 2 – Enclosing Rectangles Permitted Unprotected Areas in Unsprinklered Buildings
Paragraphs 7.3.12, 7.3.13, 7.3.14, 7.3.15 b), 7.5.2, 7.5.3, 7.5.5 and Figures 7.5, 7.6 and 7.8

Distance to relevant boundary (m)	Percentage permitted unprotected area																								
	Fire Hazard Category 1						Fire Hazard Category 2						Fire Hazard Category 3 and 4												
	Width of enclosing rectangle (m)						Width of enclosing rectangle (m)						Width of enclosing rectangle (m)												
	2	3	4	6	8	10	15	20	2	3	4	6	8	10	15	20	2	3	4	6	8	10	15	20	
1.0	100	100	100	97	93	91	90	89	100	96	84	74	71	70	69	68	84	64	56	50	48	47	46	46	
1.1				100	98	96	94	94	100	100	89	78	75	73	72	72	91	69	60	53	50	49	48	48	
1.2					100	100	99	98			95	83	79	77	75	75	99	74	64	56	53	52	51	50	
1.3						100	100	100	100	100	87	83	80	79	78	78	100	80	68	59	56	54	53	53	
1.4											92	86	84	82	81	81		85	72	62	58	57	55	55	
1.5											97	91	88	85	85	85		91	77	65	61	59	57	57	
1.6											100	95	92	89	88	88		97	81	68	64	62	60	59	
1.7												99	95	92	91	91		100	86	72	67	64	62	61	
1.8												100	99	96	95	95			91	75	70	67	64	64	
1.9													100	99	98	98			96	79	72	69	67	66	
2.0														100	100	100			100	83	76	72	69	68	
2.1																				87	79	75	72	71	
2.2																					90	82	78	74	73
2.3																					94	85	81	76	75
2.4																					99	88	83	79	78
2.5																				100	92	86	81	80	
2.6																					95	89	84	82	
2.7																					99	92	86	85	
2.8																					100	95	89	87	
2.9																						99	91	89	
3.0																						100	94	92	
3.4																							100	100	

Notes:

1. Percentage *unprotected areas* may be linearly interpolated between enclosing rectangle widths and between distances to the *relative boundary*.
2. For enclosing rectangle widths greater than 20 m, an enclosing rectangle width of 20 m may be used.

Distance to relevant boundary (m)		Method 2 – Enclosing Rectangles Permitted Unprotected Areas in Unsprinklered Buildings																							
		Fire Hazard Category 1						Percentage permitted unprotected area						Fire Hazard Category 3 and 4											
		Width of enclosing rectangle (m)						Width of enclosing rectangle (m)						Width of enclosing rectangle (m)											
		2	3	4	6	8	10	15	20	2	3	4	6	8	10	15	20	2	3	4	6	8	10	15	20
1.0		90	69	60	53	51	50	49	49	69	53	46	40	39	38	37	37	46	35	31	27	26	25	25	25
1.1		97	74	64	56	53	52	51	51	74	56	49	42	40	40	39	39	50	38	33	29	27	27	26	26
1.2		100	79	67	58	55	54	53	53	80	60	51	45	42	41	40	40	54	40	35	30	28	28	27	27
1.3			84	71	61	58	56	55	55	86	64	54	47	44	43	42	42	58	43	37	32	30	29	28	28
1.4			89	75	64	60	59	57	57	92	68	58	49	46	45	44	43	62	46	39	33	31	30	29	29
1.5			95	80	67	63	61	59	59	98	72	61	51	48	46	45	45	66	49	41	35	32	31	30	30
1.6			100	84	71	65	63	61	61	100	77	64	54	50	48	47	46	71	52	43	36	34	32	31	31
1.7				89	74	68	66	63	63		81	68	56	52	50	48	48	75	55	46	38	35	34	33	32
1.8				93	77	71	68	66	65		86	71	59	54	52	50	50	80	58	48	40	36	35	34	33
1.9				98	81	74	71	68	67		91	75	62	56	54	52	51	85	61	51	41	38	36	35	34
2.0				100	84	77	73	70	69		96	79	64	59	56	53	53	90	65	53	43	39	38	36	36
2.1					88	80	76	72	71		100	83	67	61	58	55	54	95	68	56	45	41	39	37	37
2.2					92	83	78	75	73			87	70	63	60	57	56	100	72	59	47	42	40	38	38
2.3					95	86	81	77	76			91	73	65	62	59	58		76	61	49	44	42	40	39
2.4					99	89	84	79	78			96	76	68	64	60	59		80	64	51	46	43	41	40
2.5					100	92	87	82	80			100	79	70	66	62	61		84	67	53	47	45	42	41
2.6						95	90	84	82			82	73	68	64	63	63		88	71	55	49	46	43	42
2.7						99	92	86	85			85	75	71	66	64	64		92	74	57	51	48	44	43
2.8						100	95	89	87			89	78	73	68	66	66		96	77	60	53	49	46	45
2.9							98	91	89			92	81	75	70	68	68		100	80	62	54	51	47	46
3.0							100	94	91			96	84	77	72	70	70			84	64	56	52	48	47
3.5								100	100			100	98	90	81	79	79			100	77	66	60	55	53
4.0													100	100	92	88	88				91	77	69	62	59
5.0															100	100	100				100	100	90	77	72
6.9																							100	100	100

Notes:

1. Percentage unprotected areas may be linearly interpolated between enclosing rectangle widths and between distances to the relevant boundary.
2. For enclosing rectangle widths greater than 20 m, an enclosing rectangle width of 20 m may be used.

Rectangle height 3 m

Table 7.2/3: Method 2 – Enclosing rectangles Permitted Unprotected Areas in Unsprinklered buildings

Distance to relevant boundary (m)	Percentage permitted unprotected area																								
	Fire Hazard Category 1					Fire Hazard Category 2					Fire Hazard Category 3 and 4														
	Width of enclosing rectangle (m)					Width of enclosing rectangle (m)					Width of enclosing rectangle (m)														
	2	3	4	6	8	10	15	20	2	3	4	6	8	10	15	20	2	3	4	6	8	10	15	20	30
1.0	69	52	45	40	38	37	36	36	53	40	35	30	29	28	28	28	35	27	23	20	19	19	19	19	19
1.1	74	56	48	42	39	38	37	37	56	42	36	32	30	29	29	29	38	29	24	21	20	20	19	19	19
1.2	79	59	50	43	41	40	39	39	60	45	38	33	31	30	30	29	40	30	26	22	21	20	20	20	20
1.3	84	62	53	45	42	41	40	40	64	47	40	34	32	31	30	30	43	32	27	23	22	21	21	20	20
1.4	89	66	55	47	44	43	41	41	68	50	42	36	34	33	32	31	46	34	28	24	23	22	21	21	21
1.5	95	69	58	49	46	44	43	42	72	53	44	37	35	34	33	32	49	36	30	25	23	22	22	22	22
1.6	100	73	61	51	47	46	44	44	77	56	47	39	36	35	34	33	52	38	31	26	24	23	23	22	22
1.7		77	64	53	49	47	45	45	81	59	49	41	37	36	35	34	55	40	33	27	25	24	23	23	23
1.8		82	67	55	51	49	47	46	86	62	51	42	39	37	36	35	58	42	35	28	26	25	24	24	24
1.9		86	71	58	53	50	48	48	91	66	54	44	40	38	37	36	61	44	36	30	27	26	25	24	24
2.0		90	74	60	54	52	50	49	96	69	56	46	42	40	38	37	65	46	38	31	28	27	25	25	25
2.1		95	77	62	56	54	51	50	100	72	59	48	43	41	39	38	68	49	40	32	29	28	26	26	26
2.2		100	81	65	58	55	53	52		76	62	49	45	42	40	39	72	51	42	33	30	28	27	27	26
2.3			85	67	60	57	54	53		80	65	51	46	44	41	40	76	54	44	35	31	29	28	27	27
2.4			89	70	62	59	55	54		84	68	53	48	45	42	42	80	56	46	36	32	30	28	28	28
2.5			93	73	65	61	57	56		88	71	55	49	46	43	43	84	59	48	37	33	31	29	29	28
2.6			97	75	67	63	59	57		92	74	58	51	48	45	44	88	62	50	39	34	32	30	29	29
2.7			100	78	69	64	60	59		96	77	60	53	49	46	45	92	65	52	40	35	33	31	30	30
2.8			81	71	66	62	60	60	100	80	62	54	51	47	46	46	96	68	54	42	37	34	32	31	30
2.9			84	74	68	63	62	62		83	64	56	52	48	47	47	100	71	56	43	38	35	32	32	31
3.0			87	76	70	65	63	63		87	67	58	54	49	48	48	74	58	45	39	36	33	32	32	32
4.0			100	100	92	82	79	79	100	93	78	71	63	60	60	60	100	85	62	53	48	42	40	39	39
5.0			100	100	100	100	95	95	100	100	100	100	91	77	73	73	100	84	69	61	52	49	47	47	
6.0							100	100	100	100	100	100	94	87	87	87	100	88	77	63	58	55	55	55	
7.0									100	100	100	100	100	100	100	100	100	100	94	76	69	63	63	63	
8.0																	100	100	90	80	72	72	72	72	
9.0																	100	100	92	82	82	82	82	82	
9.7																	100	100	100	88	88	88	88	88	
10.8																	100	100	100	100	100	100	100	100	

Notes:

1. Percentage *unprotected areas* may be linearly interpolated between enclosing rectangle widths and between distances to the *relative boundary*.
2. For enclosing rectangle widths greater than the maximum values given in the table, an enclosing rectangle width of 20 m for FHC 1 and 2 or 30 m for FHC 3 and 4 may be used.

Rectangle height 4 m

Table 7.2/4: Method 2 – Enclosing Rectangles Permitted Unprotected Areas in Unsprinklered Buildings

Distance to relevant boundary (m)	Percentage permitted unprotected area																								
	Fire Hazard Category 1					Fire Hazard Category 2					Fire Hazard Category 3 and 4														
	Width of enclosing rectangle (m)					Width of enclosing rectangle (m)					Width of enclosing rectangle (m)														
	2	3	4	6	8	10	15	20	2	3	4	6	8	10	15	20	2	3	4	6	8	10	15	20	30
1.0	60	45	39	34	32	31	31	31	46	35	30	26	25	24	24	23	31	23	20	17	17	16	16	16	16
1.1	64	48	41	35	33	32	32	32	49	36	31	27	25	25	24	23	33	24	21	18	17	17	16	16	16
1.2	67	50	43	37	34	33	33	32	51	38	33	28	26	25	25	25	35	26	22	19	18	17	17	17	17
1.3	71	53	45	38	35	34	33	33	54	40	34	29	27	26	26	25	37	27	23	19	18	17	17	17	17
1.4	75	55	47	39	37	35	34	34	58	42	36	30	28	27	26	26	39	28	24	20	19	18	17	17	17
1.5	80	58	49	41	38	36	35	35	61	44	37	31	29	28	27	27	41	30	25	21	19	18	18	18	18
1.6	84	61	51	42	39	37	36	36	64	47	39	32	30	29	28	27	43	31	26	22	20	19	19	18	18
1.7	89	64	53	44	40	39	37	37	68	49	41	33	31	29	28	28	46	33	27	22	21	20	19	19	19
1.8	93	67	56	45	42	40	38	38	71	51	42	35	32	30	29	29	48	35	29	23	21	20	19	19	19
1.9	98	71	58	47	43	41	39	39	75	54	44	36	33	31	30	29	51	36	30	24	22	21	20	20	20
2.0	100	74	60	49	44	42	40	39	79	56	46	37	34	32	31	30	53	38	31	25	23	22	21	20	20
2.1		77	63	51	46	43	41	40	83	59	48	39	35	33	31	31	56	40	32	26	23	22	21	21	21
2.2		81	66	52	47	44	42	41	87	62	50	40	36	34	32	32	59	42	34	27	24	23	22	21	21
2.3		85	69	54	49	46	43	42	91	65	52	41	37	35	33	32	61	44	35	28	25	24	22	22	22
2.4		89	71	56	50	47	44	43	96	68	54	43	38	36	34	33	64	46	37	29	26	24	23	22	22
2.5		93	74	58	52	48	45	44	100	71	57	44	39	37	35	34	67	48	38	30	26	25	23	23	23
2.6		97	77	60	53	50	46	45		74	59	46	41	38	35	35	71	50	40	31	27	26	24	23	23
2.7		100	80	62	55	51	48	46		77	61	48	42	39	36	35	74	52	41	32	28	26	24	24	24
2.8		84	64	56	53	49	47		80	64	49	43	40	37	36	77	54	43	33	29	27	25	24	24	
2.9		87	67	58	54	50	49		83	66	51	44	41	38	37	80	56	45	34	30	28	26	25	25	
3.0		90	69	60	55	51	50		87	69	53	46	42	39	38	84	58	46	35	31	28	26	25	25	
4.0		100	95	80	72	64	61		100	98	72	61	55	49	46	100	85	66	49	41	37	33	31	30	
5.0		100	100	91	78	73		100	96	79	70	60	56		100	90	65	53	47	40	38	36	36		
6.0			100	94	87		100	100	100	100	100	87	72	66		100	84	67	59	48	45	42	42		
7.0				100	100		100	100	100	100	100	86	77		100	84	72	58	52	48	48	48			
8.0							100	100	100	100	100	90		100	87	68	60	55	55	55	55	55			
9.0											100	100		100	79	69	62	62	62	62	62	62			
10.0															92	79	69	69	69	69	69	69	69		
11.0															100	90	77	77	77	77	77	77	77		
11.9															100	100	100	100	100	100	100	100	100		

Notes:

1. Percentage unprotected areas may be linearly interpolated between enclosing rectangle widths and between distances to the relative boundary.
2. For enclosing rectangle widths greater than the maximum values given in the table, an enclosing rectangle width of 20 m for FHC 1 and 2 or 30 m for FHC 3 and 4 may be used.

Rectangle height 6 m

Table 7.2/5: Method 2 – Enclosing Rectangles Permitted Unprotected Areas in Unsprinklered Buildings

Distance to relevant boundary (m)	Percentage permitted unprotected area																								
	Fire Hazard Category 1					Fire Hazard Category 2					Fire Hazard Category 3 and 4														
	Width of enclosing rectangle (m)					Width of enclosing rectangle (m)					Width of enclosing rectangle (m)														
	2	3	4	6	8	10	15	20	2	3	4	6	8	10	15	20	2	3	4	6	8	10	15	20	30
1.0	53	40	34	29	28	27	26	26	40	30	26	22	21	21	20	20	27	20	17	15	14	14	13	13	
1.1	56	42	35	30	28	27	27	27	42	32	27	23	22	21	20	20	29	21	18	16	15	14	14	14	
1.2	58	43	37	31	29	28	27	27	45	33	28	24	22	21	21	21	30	22	19	16	15	14	14	14	
1.3	61	45	38	32	30	29	28	27	47	34	29	24	23	22	21	21	32	23	19	16	15	14	14	14	
1.4	64	47	39	33	30	29	28	28	49	36	30	25	23	22	21	21	33	24	20	17	16	15	14	14	
1.5	67	49	41	34	31	30	29	28	51	37	31	26	24	23	22	22	35	25	21	17	16	15	15	15	
1.6	71	51	42	35	32	31	29	29	54	39	32	27	24	23	22	22	36	26	22	18	16	16	15	15	
1.7	74	53	44	36	33	31	30	29	56	41	33	27	25	24	23	22	38	27	22	18	17	16	15	15	
1.8	77	55	45	37	33	32	30	30	59	42	35	28	26	24	23	23	40	28	23	19	17	16	16	15	
1.9	81	58	47	38	34	33	31	30	62	44	36	29	26	25	24	23	41	30	24	19	18	17	16	16	
2.0	84	60	49	39	35	33	32	31	64	46	37	30	27	25	24	24	43	31	25	20	18	17	16	16	
2.1	88	62	51	40	36	34	32	32	67	48	39	31	28	26	25	24	45	32	26	21	19	17	16	16	
2.2	92	65	52	41	37	35	33	32	70	49	40	32	28	27	25	25	47	33	27	21	19	18	17	16	
2.3	95	67	54	43	38	36	33	33	73	51	41	33	29	27	25	25	49	35	28	22	19	18	17	17	
2.4	99	70	56	44	39	36	34	33	76	53	43	34	30	28	26	25	51	36	29	23	20	19	17	17	
2.5	100	73	58	45	40	37	35	34	79	55	44	35	30	28	26	26	53	37	30	23	20	19	18	17	
2.6		75	60	47	41	38	36	35	82	58	46	36	31	29	27	26	55	39	31	24	21	20	18	17	
2.7		78	62	48	42	39	36	35	85	60	48	37	32	30	28	27	57	40	32	25	22	20	19	18	
2.8		81	64	49	43	40	37	36	89	62	49	38	33	30	28	27	60	42	33	25	22	20	19	18	
2.9		84	67	51	44	41	37	36	92	64	51	39	34	31	29	28	62	43	34	26	23	21	19	18	
3.0		87	69	52	45	42	38	37	96	67	53	40	35	32	29	28	64	45	35	27	23	21	20	19	
4.0	100	95	69	58	52	46	44	44	100	93	72	53	44	40	35	34	91	62	49	36	30	27	24	23	
5.0	100	90	74	65	55	52	52	52	100	96	69	56	50	42	40	40	100	84	65	46	38	33	28	27	
6.0	100	100	93	80	66	61	61	61	100	100	88	71	61	50	46	46	100	84	59	48	41	34	31	29	
7.0	100	100	97	78	70	70	70	70	100	100	87	74	60	54	54	54	100	74	58	50	40	36	33	33	
8.0	100	100	91	81	81	81	81	81	100	100	89	70	62	62	62	62	100	90	71	60	47	42	38	38	
9.0	100	100	100	92	92	92	92	92	100	100	100	81	71	71	71	71	100	100	85	71	54	48	42	42	
10.0	100	100	100	100	100	100	100	100	100	100	100	93	80	80	80	80	100	100	100	83	63	54	47	47	
11.0	100	100	100	100	100	100	100	100	100	100	100	100	91	91	91	91	100	100	100	97	72	61	52	52	
12.0	100	100	100	100	100	100	100	100	100	100	100	100	100	100	100	100	100	100	100	100	100	82	68	58	
13.0	100	100	100	100	100	100	100	100	100	100	100	100	100	100	100	100	100	100	100	100	100	92	77	63	
14.0	100	100	100	100	100	100	100	100	100	100	100	100	100	100	100	100	100	100	100	100	100	100	85	69	
15.6	100	100	100	100	100	100	100	100	100	100	100	100	100	100	100	100	100	100	100	100	100	100	100	100	

Notes:

- Percentage unprotected areas may be linearly interpolated between enclosing rectangle widths and between distances to the relative boundary.
- For enclosing rectangle widths greater than the maximum values given in the table, an enclosing rectangle width of 20 m for FHC 1 and 2 or 30 m for FHC 3 and 4 may be used.

Rectangle height 9 m

Table 7.2/6: Method 2 – Enclosing Rectangles Permitted Unprotected Areas in Unsprinklered Buildings

Distance to relevant boundary (m)	Percentage permitted unprotected area																								
	Fire Hazard Category 1					Fire Hazard Category 2					Fire Hazard Category 3 and 4														
	Width of enclosing rectangle (m)					Width of enclosing rectangle (m)					Width of enclosing rectangle (m)														
	2	3	4	6	8	10	15	20	2	3	4	6	8	10	15	20	2	3	4	6	8	10	15	20	30
1.0	50	37	32	27	26	25	24	24	38	29	24	21	20	19	18	18	26	19	16	14	13	13	12	12	
1.1	52	39	33	28	26	25	24	24	40	30	25	21	20	19	18	18	27	20	17	14	13	13	12	12	
1.2	55	40	34	28	26	25	24	24	42	31	26	22	20	19	19	19	28	21	17	15	14	13	12	12	
1.3	57	42	35	29	27	26	25	25	43	32	27	22	20	19	19	19	29	21	18	15	14	13	13	13	
1.4	59	43	36	30	27	26	25	25	45	33	27	23	21	20	19	19	30	22	18	15	14	13	13	13	
1.5	62	45	37	30	28	27	25	25	47	34	28	23	21	20	19	19	32	23	19	16	14	13	13	13	
1.6	64	46	38	31	28	27	26	25	49	35	29	24	22	21	20	19	33	24	20	16	15	14	13	13	
1.7	67	48	39	32	29	27	26	26	51	37	30	24	22	21	20	20	34	25	20	16	15	14	13	13	
1.8	69	50	40	33	29	28	26	26	53	38	31	25	22	21	20	20	36	25	21	17	15	14	13	13	
1.9	72	51	42	33	30	28	27	26	55	39	32	25	23	22	20	20	37	26	21	17	15	14	13	13	
2.0	75	53	43	34	30	29	27	26	57	40	33	26	23	22	21	20	38	27	22	17	16	15	14	13	
2.1	77	55	44	35	31	29	27	27	59	42	34	27	24	22	21	20	40	28	23	18	16	15	14	14	
2.2	80	57	46	36	32	30	28	27	61	43	35	27	24	23	21	21	41	29	23	18	16	15	14	14	
2.3	83	58	47	37	32	30	28	27	63	45	36	28	25	23	21	21	43	30	24	19	17	15	14	14	
2.4	86	60	48	37	33	31	28	28	66	46	37	29	25	23	22	21	44	31	25	19	17	15	14	14	
2.5	89	62	50	38	34	31	29	28	68	48	38	29	26	24	22	21	46	32	26	20	17	16	15	14	
2.6	92	64	51	39	34	32	29	28	70	49	39	30	26	24	22	22	47	33	26	20	18	16	15	14	
2.7	95	66	53	40	35	32	30	29	73	51	40	31	27	25	23	22	49	34	27	21	18	17	15	15	
2.8	98	68	54	41	36	33	30	29	75	52	41	31	27	25	23	22	50	35	28	21	18	17	15	15	
2.9	100	71	56	42	36	33	31	30	77	54	43	32	28	26	23	23	52	36	29	22	19	17	16	15	
3.0	100	73	57	43	37	34	31	30	80	55	44	33	28	26	24	23	54	37	29	22	19	18	16	15	
4.0	100	97	75	55	46	41	36	34	100	74	57	42	35	31	27	26	73	50	39	28	24	21	18	17	
5.0	100	97	69	56	49	42	39	39	100	96	74	53	43	38	32	30	95	64	50	35	29	25	21	20	
6.0	100	100	86	69	59	49	45	45	100	100	93	65	52	45	37	34	100	82	62	44	35	30	25	23	
7.0	100	100	83	71	56	51	51	51	100	100	80	63	54	43	39	39	100	77	54	43	36	29	26	24	
8.0	100	100	84	65	58	58	58	58	100	100	96	76	64	50	44	44	100	94	65	51	43	33	30	27	
9.0	100	100	100	98	75	65	65	65	100	100	100	89	75	57	50	50	100	100	77	60	50	38	33	30	
10.0	100	100	100	100	86	73	73	73	100	100	100	100	87	65	56	56	100	100	91	70	58	44	38	33	
11.0	100	100	100	100	97	82	82	82	100	100	100	100	100	74	63	63	100	100	100	81	67	50	42	36	
12.0	100	100	100	100	100	92	92	92	100	100	100	100	84	70	70	70	100	100	100	94	77	57	47	40	
13.0	100	100	100	100	100	100	100	100	100	100	100	100	94	78	78	78	100	100	100	100	88	64	53	43	
14.0	100	100	100	100	100	100	100	100	100	100	100	100	100	87	87	87	100	100	100	100	99	71	58	48	
16.0	100	100	100	100	100	100	100	100	100	100	100	100	100	100	100	100	100	100	100	100	100	100	88	71	
18.0	100	100	100	100	100	100	100	100	100	100	100	100	100	100	100	100	100	100	100	100	100	100	100	85	66
19.9	100	100	100	100	100	100	100	100	100	100	100	100	100	100	100	100	100	100	100	100	100	100	100	100	100

Notes:

- Percentage *unprotected areas* may be linearly interpolated between enclosing rectangle widths and between distances to the *relative boundary*.
- For enclosing rectangle widths greater than the maximum values given in the table, an enclosing rectangle width of 20 m for FHC 1 and 2 or 30 m for FHC 3 and 4 may be used.

Table 7.3: Method 4 – Return Walls and Wing Walls for Unsprinklered Firecells Protection of Other Property
Paragraphs 7.3.13, 7.3.15, 7.7.1, 7.7.4, 7.7.5, 7.7.6 and 7.7.7

Equivalent opening height h_{eq} (m)	Return walls										Wing walls													
	Minimum separation distance between unprotected areas and notional boundary D_B (m)										Minimum length of wing wall if located on the relevant boundary L_B (m)													
	Equivalent opening width W_{eq} (m)										Equivalent opening width W_{eq} (m)													
Fire hazard category 1	1	2	3	4	6	8	10	20	1	2	3	4	6	8	10	20	1	2	3	4	6	8	10	20
	0.2	0.2	0.2	0.2	0.2	0.2	0.2	0.2	0.4	0.4	0.4	0.4	0.4	0.4	0.4	0.4	0.4	0.4	0.4	0.4	0.4	0.4	0.4	0.4
	0.2	0.2	0.2	0.2	0.2	0.2	0.2	0.2	0.4	0.4	0.4	0.5	0.5	0.5	0.5	0.5	0.4	0.4	0.4	0.5	0.5	0.5	0.5	0.5
	0.2	0.2	0.2	0.2	0.2	0.2	0.2	0.2	0.4	0.4	0.4	0.5	0.5	0.5	0.5	0.5	0.4	0.4	0.4	0.6	0.6	0.6	0.7	0.7
	0.2	0.2	0.2	0.2	0.2	0.2	0.2	0.2	0.4	0.4	0.4	0.5	0.5	0.5	0.5	0.5	0.4	0.4	0.4	0.7	0.7	0.7	0.8	0.8
	0.2	0.2	0.2	0.2	0.2	0.2	0.2	0.2	0.4	0.4	0.4	0.5	0.5	0.5	0.5	0.5	0.4	0.4	0.4	0.8	0.8	0.9	0.9	0.9
	0.2	0.2	0.2	0.2	0.2	0.2	0.2	0.2	0.4	0.4	0.4	0.5	0.5	0.5	0.5	0.5	0.4	0.4	0.4	0.9	0.9	1.1	1.2	1.3
	0.2	0.2	0.2	0.2	0.2	0.2	0.2	0.2	0.4	0.4	0.4	0.5	0.5	0.5	0.5	0.5	0.4	0.4	0.4	1.0	1.0	1.3	1.5	1.6
	0.2	0.2	0.2	0.2	0.2	0.2	0.2	0.2	0.4	0.4	0.4	0.5	0.5	0.5	0.5	0.5	0.4	0.4	0.4	1.1	1.1	1.4	1.7	1.9
	0.2	0.2	0.2	0.2	0.2	0.2	0.2	0.2	0.4	0.4	0.4	0.5	0.5	0.5	0.5	0.5	0.4	0.4	0.4	1.1	1.1	1.4	1.7	1.9
Fire hazard category 2	1	2	3	4	6	8	10	20	1	2	3	4	6	8	10	20	1	2	3	4	6	8	10	20
	0.2	0.2	0.2	0.2	0.2	0.2	0.2	0.2	0.4	0.4	0.4	0.4	0.4	0.4	0.4	0.4	0.4	0.4	0.4	0.4	0.4	0.4	0.4	0.4
	0.2	0.2	0.2	0.2	0.2	0.2	0.2	0.2	0.4	0.4	0.4	0.4	0.4	0.4	0.4	0.4	0.4	0.4	0.4	0.4	0.4	0.4	0.4	0.4
	0.2	0.2	0.2	0.2	0.2	0.2	0.2	0.2	0.4	0.4	0.4	0.4	0.4	0.4	0.4	0.4	0.4	0.4	0.4	0.4	0.4	0.4	0.4	0.4
	0.2	0.2	0.2	0.2	0.2	0.2	0.2	0.2	0.4	0.4	0.4	0.4	0.4	0.4	0.4	0.4	0.4	0.4	0.4	0.4	0.4	0.4	0.4	0.4
	0.2	0.2	0.2	0.2	0.2	0.2	0.2	0.2	0.4	0.4	0.4	0.4	0.4	0.4	0.4	0.4	0.4	0.4	0.4	0.4	0.4	0.4	0.4	0.4
	0.2	0.2	0.2	0.2	0.2	0.2	0.2	0.2	0.4	0.4	0.4	0.4	0.4	0.4	0.4	0.4	0.4	0.4	0.4	0.4	0.4	0.4	0.4	0.4
	0.2	0.2	0.2	0.2	0.2	0.2	0.2	0.2	0.4	0.4	0.4	0.4	0.4	0.4	0.4	0.4	0.4	0.4	0.4	0.4	0.4	0.4	0.4	0.4
	0.2	0.2	0.2	0.2	0.2	0.2	0.2	0.2	0.4	0.4	0.4	0.4	0.4	0.4	0.4	0.4	0.4	0.4	0.4	0.4	0.4	0.4	0.4	0.4
	0.2	0.2	0.2	0.2	0.2	0.2	0.2	0.2	0.4	0.4	0.4	0.4	0.4	0.4	0.4	0.4	0.4	0.4	0.4	0.4	0.4	0.4	0.4	0.4
Fire hazard category 3 & 4	1	2	3	4	6	8	10	20	1	2	3	4	6	8	10	20	1	2	3	4	6	8	10	20
	0.4	0.4	0.4	0.4	0.4	0.4	0.4	0.4	0.6	0.6	0.6	0.6	0.6	0.6	0.6	0.6	0.6	0.6	0.6	0.6	0.6	0.6	0.6	0.6
	0.4	0.4	0.4	0.4	0.4	0.4	0.4	0.4	0.6	0.6	0.6	0.6	0.6	0.6	0.6	0.6	0.6	0.6	0.6	0.6	0.6	0.6	0.6	0.6
	0.4	0.4	0.4	0.4	0.4	0.4	0.4	0.4	0.6	0.6	0.6	0.6	0.6	0.6	0.6	0.6	0.6	0.6	0.6	0.6	0.6	0.6	0.6	0.6
	0.4	0.4	0.4	0.4	0.4	0.4	0.4	0.4	0.6	0.6	0.6	0.6	0.6	0.6	0.6	0.6	0.6	0.6	0.6	0.6	0.6	0.6	0.6	0.6
	0.4	0.4	0.4	0.4	0.4	0.4	0.4	0.4	0.6	0.6	0.6	0.6	0.6	0.6	0.6	0.6	0.6	0.6	0.6	0.6	0.6	0.6	0.6	0.6
	0.4	0.4	0.4	0.4	0.4	0.4	0.4	0.4	0.6	0.6	0.6	0.6	0.6	0.6	0.6	0.6	0.6	0.6	0.6	0.6	0.6	0.6	0.6	0.6
	0.4	0.4	0.4	0.4	0.4	0.4	0.4	0.4	0.6	0.6	0.6	0.6	0.6	0.6	0.6	0.6	0.6	0.6	0.6	0.6	0.6	0.6	0.6	0.6
	0.4	0.4	0.4	0.4	0.4	0.4	0.4	0.4	0.6	0.6	0.6	0.6	0.6	0.6	0.6	0.6	0.6	0.6	0.6	0.6	0.6	0.6	0.6	0.6
	0.4	0.4	0.4	0.4	0.4	0.4	0.4	0.4	0.6	0.6	0.6	0.6	0.6	0.6	0.6	0.6	0.6	0.6	0.6	0.6	0.6	0.6	0.6	0.6

Note:
The values of D_B or L_B may be linearly interpolated where exact values of h_{eq} or W_{eq} are not shown in the table.

Table 7.4: Method 4 – Return Walls and Wing Walls for Unsprinklered Firecells
Protection of Sleeping Purpose Groups or Safe Paths on the Same Property
Paragraphs 7.3.13, 7.7.1, 7.7.4, 7.7.5, 7.7.6 and 7.7.7

Equivalent opening height h_{eq} (m)	Return walls										Wing walls													
	Minimum separation distance between unprotected areas and notional boundary D_B (m)										Minimum length of wing wall if located on the relevant boundary L_B (m)													
	Equivalent opening width W_{eq} (m)										Equivalent opening width W_{eq} (m)													
	1	2	3	4	6	8	10	20	1	2	3	4	6	8	10	20	1	2	3	4	6	8	10	20
Fire hazard category 1	1	0.2	0.2	0.2	0.2	0.2	0.2	0.2	0.2	0.2	0.2	0.2	0.2	0.2	0.2	0.2	0.5	0.5	0.6	0.6	0.6	0.6	0.6	0.6
	2	0.2	0.2	0.2	0.2	0.2	0.2	0.2	0.2	0.2	0.2	0.2	0.2	0.2	0.2	0.2	0.6	0.9	1.0	1.1	1.2	1.2	1.2	1.2
	3	0.2	0.2	0.2	0.2	0.2	0.2	0.2	0.2	0.2	0.2	0.2	0.2	0.2	0.2	0.2	0.7	1.1	1.3	1.4	1.6	1.7	1.8	1.8
	4	0.2	0.2	0.2	0.2	0.2	0.3	0.3	0.3	0.3	0.3	0.3	0.3	0.3	0.3	0.3	0.7	1.2	1.5	1.8	2.0	2.2	2.3	2.4
	6	0.2	0.2	0.2	0.3	0.3	0.4	0.5	0.5	0.5	0.5	0.5	0.5	0.5	0.5	0.5	0.7	1.3	1.8	2.1	2.6	2.9	3.1	3.5
Fire hazard category 2	8	0.2	0.2	0.3	0.3	0.4	0.5	0.6	0.6	0.6	0.6	0.6	0.6	0.6	0.6	0.7	1.3	1.8	2.3	3.0	3.5	3.8	4.5	
	10	0.2	0.2	0.3	0.4	0.5	0.6	0.7	0.7	0.7	0.7	0.7	0.7	0.7	0.7	0.7	1.4	2.0	2.5	3.3	3.9	4.4	5.4	
	1	0.2	0.2	0.2	0.2	0.2	0.2	0.2	0.2	0.2	0.2	0.2	0.2	0.2	0.2	0.2	0.6	0.7	0.8	0.8	0.9	0.9	0.9	0.9
	2	0.2	0.2	0.2	0.2	0.2	0.2	0.2	0.2	0.2	0.2	0.2	0.2	0.2	0.2	0.2	0.8	1.1	1.4	1.5	1.6	1.7	1.7	1.7
	3	0.2	0.2	0.2	0.3	0.3	0.3	0.3	0.4	0.4	0.4	0.4	0.4	0.4	0.4	0.4	0.8	1.4	1.7	1.9	2.2	2.3	2.4	2.5
Fire hazard category 3 & 4	4	0.2	0.2	0.3	0.4	0.4	0.4	0.5	0.5	0.5	0.5	0.5	0.5	0.5	0.5	0.9	1.5	2.0	2.3	2.7	2.9	3.1	3.3	
	6	0.2	0.3	0.4	0.5	0.5	0.6	0.6	0.7	0.7	0.7	0.7	0.7	0.7	0.7	0.9	1.7	2.3	2.7	3.4	3.8	4.2	4.8	
	8	0.2	0.3	0.4	0.5	0.6	0.7	0.8	0.8	0.9	0.9	0.9	0.9	0.9	0.9	0.9	1.7	2.4	3.0	3.9	4.5	5.0	6.2	
	10	0.2	0.3	0.4	0.5	0.6	0.8	0.9	1.1	1.1	1.1	1.1	1.1	1.1	1.1	0.9	1.8	2.5	3.2	4.2	5.0	5.6	7.2	
	1	0.4	0.4	0.4	0.4	0.4	0.4	0.4	0.4	0.4	0.4	0.4	0.4	0.4	0.4	0.4	0.8	1.1	1.2	1.3	1.3	1.4	1.4	1.4
2	0.4	0.4	0.4	0.4	0.4	0.4	0.4	0.4	0.4	0.4	0.4	0.4	0.4	0.4	0.4	1.0	1.5	1.9	2.1	2.3	2.5	2.6	2.7	
3	0.4	0.4	0.4	0.5	0.5	0.6	0.6	0.6	0.6	0.6	0.6	0.6	0.6	0.6	0.6	1.1	1.8	2.3	2.6	3.1	3.4	3.6	3.9	
4	0.4	0.4	0.4	0.5	0.6	0.7	0.8	0.8	0.8	0.8	0.8	0.8	0.8	0.8	0.8	1.2	2.0	2.6	3.1	3.7	4.2	4.4	5.1	
6	0.4	0.5	0.7	0.8	1.0	1.1	1.1	1.2	1.1	1.1	1.1	1.1	1.1	1.1	1.1	1.2	2.2	3.0	3.6	4.6	5.2	5.8	7.2	
8	0.4	0.5	0.7	0.9	1.1	1.3	1.4	1.5	1.4	1.4	1.4	1.4	1.4	1.4	1.4	1.2	2.3	3.2	4.0	5.2	6.2	6.8	8.8	
10	0.4	0.5	0.8	1.0	1.3	1.4	1.5	1.9	1.4	1.4	1.4	1.4	1.4	1.4	1.4	1.2	2.4	3.4	4.2	5.6	6.7	7.6	10.5	

Note:

The values of D_B or L_B may be linearly interpolated where exact values of h_{eq} or W_{eq} are not shown in the table.

Amend 5
Oct 2005

Table 7.5: Acceptable Heat Release Rates for External Wall Cladding Systems
Paragraphs 7.3.13, 7.3.14, 7.8.6, 7.8.10 a), 7.11.2, 7.11.3, 7.11.4, C9.1.3 and Figure 7.10

Building height	Distance to relevant boundary			
	Less than 1 m	1 m or more		
	All purpose groups	Purpose groups SC, SD	Purpose groups SA, SR	All other purpose groups
Single storey	A	-	-	-
Up to 7 m	A	B	-	-
Up to 25 m	A	A	B	B (Notes 1, 2)
Over 25 m	A	A	A	B

Key:

The **external wall** cladding system shall have a peak rate of heat release and a total heat released not greater than given below for the applicable performance level (**Note 3**).

	Peak Rate of Heat Release (kW/m ²) (Note 4)	Total Heat Released (MJ/m ²) (Note 4)	
A	100	25	(The smaller the heat release value the more stringent the requirement.)
B	150	50	
-	No requirement	No requirement	

Notes:

- See Paragraph 7.11.4 for SH *purpose group* concession.
- Where the *building* is fully sprinklered in accordance with NZS 4541 or NZS 4515 (as applicable), there is no requirement.
- See Paragraph 7.11.3 for permitted variation over the wall height where a *building* contains different *purpose groups*.
- Determined by testing to AS/NZS 3837 at an irradiance of 50 kW/m² for a duration of 15 minutes (see Appendix C Paragraph C9.1).

Acceptable Solution C/AS1

Part 8: Fire Fighting

8.1 Fire Service Vehicular Access

8.1.1 Where *buildings* are located remote from the street boundaries of a property, pavements situated on the property and likely to be used for vehicular access by *fire* appliances shall:

- a) Be able to withstand a laden weight of up to 25 tonnes with an axle load of 8.2 tonnes or, have a load bearing capacity of no less than the public roadway serving the *property*, whichever is the lower, and
- b) Be trafficable in all weathers, and
- c) Have a minimum width of 4.0 m, and
- d) Provide a clear passageway of no less than 3.5 m in width and 4.0 m in height at site entrances, internal entrances and between *buildings*, and
- e) Provide access to within 18 m of at least one side of each *building*, except that when a *building* is sprinklered and has a *fire* riser main installed, access need only be to within 18 m of the inlets to these systems.

COMMENT:

Access to *buildings* for *fire* appliances will be generally via public streets, but provision is needed on large, multi-*building* sites to enable appliances to reach any *building*.

Special provisions for SC and SD purpose groups

8.1.2 Paragraph 8.1.1 gives the minimum requirements for Fire Service vehicular access. Where *buildings* contain *purpose groups* SC or SD the following additional requirements shall be met:

- a) Roadway pavements shall withstand a vehicle of multiple axles spaced at no less than 2.5 m centres, and each carrying 8.2 tonnes.

- b) Where a property includes two or more *buildings*, any one of which has a *building height* greater than 7.0 m, roadway widths shall be no less than 6.5 m and corners and turning areas shall accommodate a 99 percentile *fire* appliance.
- c) Hardstandings shall be provided adjacent to any *building* having a *building height* greater than 7.0 m. The location and extent of hardstandings shall be determined in consultation with the Fire Service.

8.2 Fire Fighting Facilities

Fire hydrant system

8.2.1 Where required by Table 4.1, a *fire* hydrant system shall be installed. Refer to Appendix A, Paragraph A2.1.1, Type 18 for *fire* hydrant system requirements.

Fire hose reels

8.2.2 Where required by Table 4.1, *fire* hose reels shall be installed on all levels. Refer to Appendix A, Paragraph A2.1.1, Type 14 for *fire* hose reel system requirements.

COMMENT:

Where *fire* hose reels are required by Table 4.1 but are inappropriate due to lack of water pressure or because of special hazards, suitable portable *fire* extinguishing equipment may be substituted.

Fire systems centre

8.2.3 A *fire* systems centre shall be provided in any *building* where required by Table 4.1. Refer to Appendix A, Paragraph A2.1.1, Type 20 for *fire* systems centre requirements including location, access, protection and *fire* safety system controls.

8.2.4 In a *building* not required to have a *fire* systems centre, the control features in Appendix A, Paragraph A2.1.1, Type 20 c) shall be located at a position with ready access from street level and protected from the effects of *fire* including debris falling from upper floors.

Fire Service lift control

8.2.5 Where required by Table 4.1, Fire Service lift control shall be installed to meet the requirements of Appendix A, Paragraph A2.1.1, Type 15.

Voice communication system

8.2.6 Where required by Table 4.1, a voice communication system to facilitate communication during emergency incidents shall be installed. Refer to Appendix A, Paragraph A2.1.1, Type 8 for voice communication system requirements.

Acceptable Solution C/AS1

Part 9: Outbreak of Fire

9.1 Solid Fuel Appliances

9.1.1 AS/NZS 2918 is an Acceptable Solution for the installation of domestic solid fuel burning appliances, whether installed in domestic or commercial situations, and *flue systems*, with the modification given in Paragraph 9.1.2. A normative Appendix is an integral part of the Standard.

9.1.2 Modification to AS/NZS 2918

Delete paragraph 3.8 and substitute the following:

“3.8 Seismic restraint

The appliance and the floor protector shall be mechanically fixed to the floor itself.

The test seismic force shall be taken as the application of a horizontal force equal to 0.40 times the appliance weight acting in any direction at the mid-height of the combustion chamber. The appliance shall not move, tilt or be dislodged from its installed position during the application of the test force.

The weight of the flue system and a wetback, if fitted, shall not be included in the test.”

Delete Section 7 and substitute the following:

“7.1 Ventilation

Ventilation shall be in accordance with Approved Document G4/AS1.

7.2 Water heating equipment

Water heating appliances installed in conjunction with the heating appliance shall be vented and comply with Approved Document G12/AS1.”

9.2 Gas Burning Appliances

9.2.1 For gas burning appliances of not more than 250 MJ/H, NZS 5261 sections 2.6.11, 2.6.12 & 2.6.13 and Appendix F are Acceptable Solutions for the construction and installation

of *flues* and sections 2.6.2, 2.6.3 & 2.7 are Acceptable Solutions for the installation of appliances, with the modification given in Paragraph 9.2.2 below.

9.2.2 Modifications to NZS 5261

Delete 2.6.2.12 and substitute the following:

“2.6.2.12 Seismic restraint

The appliance shall be mechanically fixed to the building.

The test seismic force shall be taken as the application of a horizontal force equal to 0.40 times the appliance weight acting at the centre of the appliance.

The appliance shall resist the seismic force with no significant movement.”

Add a Note to 2.5.7 as follows:

“Ventilation requirements are contained in Approved Document G4/AS1. The ventilation requirements of this Standard may exceed the performance requirements of NZBC G4.”

9.3 Oil Fired Appliances

9.3.1 AS 1691, as modified by Paragraph 9.3.2, is an Acceptable Solution for the installation of domestic oil-fired appliances.

9.3.2 Modifications to AS 1691

AS 1691 is modified as follows:

Delete paragraph 2.2.3 and substitute the following:

“2.2.3 Electrical equipment. Electrical equipment shall comply with Approved Document G9/AS1 or G9/VM1.”

Delete “CSIRO durability Class 2 or better” from paragraph 3.1.2 (b) and substitute “H5 treatment”.

Delete the Note to paragraph 3.1.2 (d).

Delete paragraph 3.1.4 and substitute the following:

“3.1.4 Stability

The appliance shall be mechanically fixed to the building.

The test seismic force on the fuel tank shall be taken as the application of a horizontal force in kilograms numerically equal to 0.40 times the tank volume in litres acting at the centre of the tank. The test seismic force on the appliance shall be taken as the application of a horizontal force equal to 0.40 times the appliance operating weight acting at the centre of the appliance.

The appliance and the fuel tank shall resist their respective seismic forces with no significant movement.”

Delete the words “without specific approval” from paragraph 3.2.8 (b).

Delete paragraph 5.1.1.

Add Note to 5.2.2:

“Note: Refer to Approved Document G4/AS1 for ventilation requirements.”

9.3.3 Sections 2 and 4 of AS/NZS 2918 are also Acceptable Solutions for the installation of *flues* for domestic oil-fired appliances.

9.4 Downlights

9.4.1 Recessed luminaires shall be installed with clearances from *building elements* including insulation either:

- a) In accordance with their classification as ‘abutted’ or ‘standard 100 mm’ or ‘specified’ in terms of NZECP 54, or
- b) Of 200 mm from the lampholder for those with no classification under NZECP 54.

9.5 Open Fires

9.5.1 Paragraphs 9.5.1 to 9.5.12 of this Acceptable Solution apply to *chimneys*.

9.5.2 *Chimneys* shall be *constructed* in accordance with Table 9.1 and Figure 9.1. They shall have:

- a) *Fireplaces* lined with *fire* bricks having a thickness of no less than 50 mm,

- b) *Fireplace* joints of *non-combustible* material and sealed against air leakage,

- c) *Chimney* brickwork of no less than a single skin of brick 90 mm thick plus a 65 mm thick layer of grout, and

- d) An expansion gap provided in *chimneys* containing *flue liners*. These *flue liners* shall be wrapped in a *combustible* material of thickness no less than 0.25 mm (for example heavy-quality *building paper*) to prevent the grout filling from bonding with the *flue liner*.

9.5.3 Cross-sectional areas of *flues* shall be no less than 0.03 m² for an open *fireplace*.

9.5.4 *Flue* linings shall be one of the following types:

- a) Clay *flue liners* with rebated or socketed joints,
- b) Imperforate clay pipes with socketed joints,
- c) High alumina cement and kiln-burnt aggregate pipes, with rebated or socketed joints, or steel collars around joints.

The linings shall be fitted with the sockets or rebates uppermost to prevent condensate running out, and to prevent any caulking material from being adversely affected. Joints between the liners, and any space between liners and the masonry, shall be filled with weak mortar or insulating concrete (see Figure 9.2 (a)).

9.5.5 *Flue liners* are not required for:

- a) Brick *chimneys* if *constructed* of two 90 mm skins of brickwork with a 65 mm grout-filled gap between (see Figure 9.2 (b)),
- b) Ordinary concrete *chimneys*,
- c) Precast pumice concrete *chimneys*.

9.5.6 Clearance above roofs shall be in accordance with Figure 4.9 of AS/NZS 2918.

9.5.7 Every *fireplace* shall have a separate *flue*.

9.5.8 *Flue* joints shall be of *non-combustible* material and sealed against air leakage.

9.5.9 *Hearths* for *fireplaces* shall:

- a) Be *constructed* of fully grouted stones, bricks or concrete of no less than 50 mm total thickness,

- b) Extend no less than 230 mm on each side of the *fireplace* opening, and no less than 380 mm forward of the *fireplace* opening, and
- c) Have no *combustible* material closer than the clearances given in Paragraph 9.5.10 b) from the upper and lower surfaces of the *hearth*.

9.5.10 Clearances between a *chimney* and any *combustible* material (see Figure 9.3), shall be no less than:

- a) 200 mm at any opening in the *flue*, or at the *fireplace* opening, and
- b) 200 mm above or below the upper surface of the *hearth*, and 75 mm from the lower surface of the *hearth*.

9.5.11 *Hearth* edges are to be separated from *combustible* material with *insulating material* having a minimum service operating temperature of 150°C.

COMMENT:

AS/NZS 2918 Appendix C gives a test method for heat-resistant and heat-tolerant materials.

9.5.12 A ventilated space of no less than 50 mm shall be provided between the outer face of a *fireplace*, *chimney* or *flue* and any *combustible* material.

Amend 3
Feb 2004

Figure 9.1: Chimney Terms and Dimensions
Paragraph 9.5.2 and Table 9.1

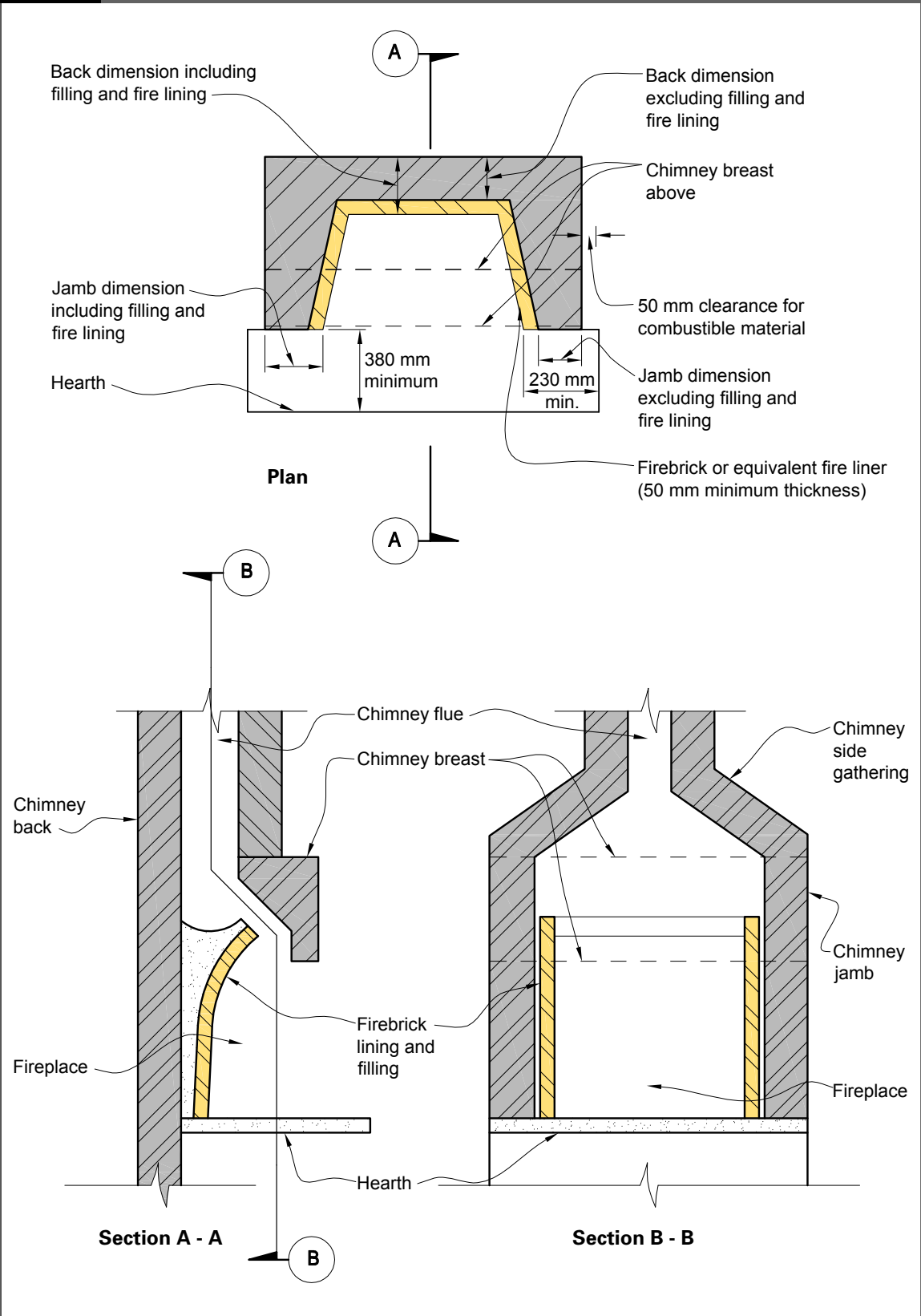

Amend 3
Feb 2004

Figure 9.2: Brick Chimney Flues – Sections
Paragraph 9.5.5

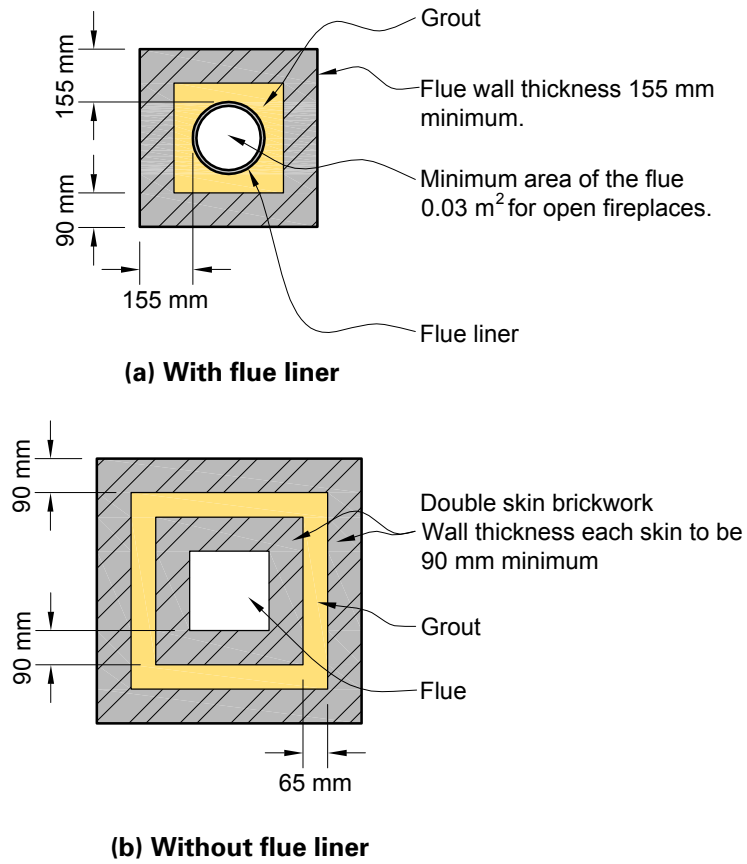

Amend 3
Feb 2004

Figure 9.3: Clearances Between a Chimney and Hearth, and Combustible Materials
Paragraph 9.5.10

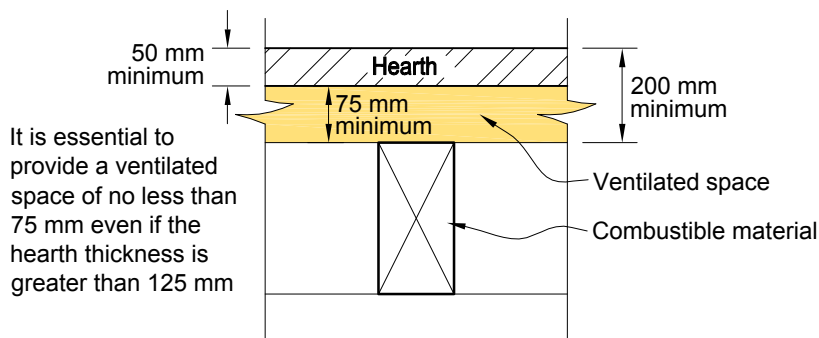
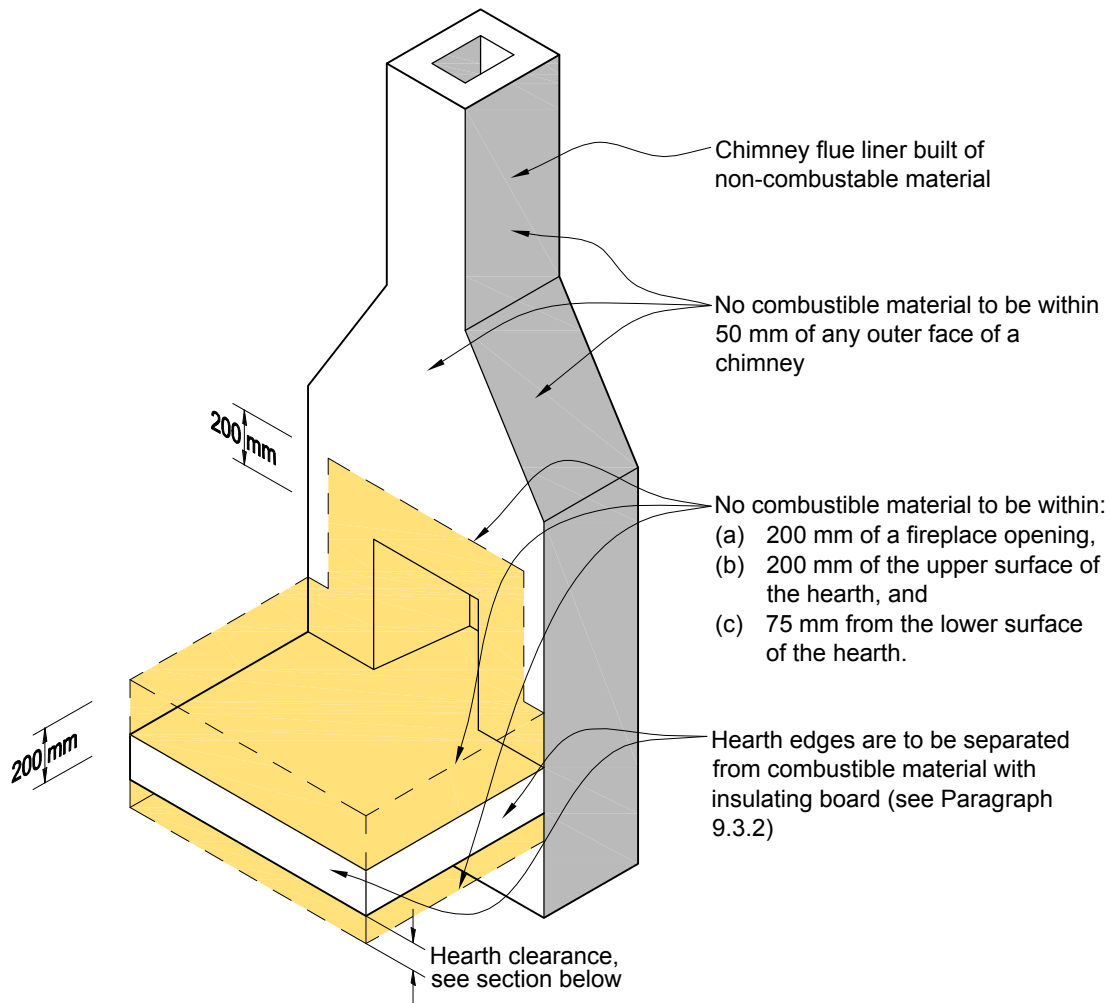

Section showing minimum dimensions

Amend 3
Feb 2004

Amend 3
Feb 2004

Table 9.1: Chimneys – Minimum Acceptable Dimensions
Paragraph 9.5.2

Chimney construction	Fireplace jamb and fireplace back thickness		Breasts and side gathering, and chimney wall thickness above the level of the gather, excluding linings (mm)
	Excluding filling and fire liner (mm)	Including filling and fire liner (mm)	
Concrete	170	255	170
Brickwork	155	230	155
Precast pumice concrete	85	170	85

Note:

Refer to Figure 9.1 for *chimney* terms and dimensions.

Appendix A: Fire Safety Precautions

A1.1 Types of FSP

A1.1.1 The Key to Table 4.1 lists different Types of *fire safety precautions*. Types 2 to 7 are alarm systems and the others are specific provisions aimed at facilitating safe evacuation, rescue and *fire* fighting activity.

A1.1.2 Depending on the *fire hazard*, one or more *FSPs* are required, by Table 4.1, to be applied to the *firecell* being considered.

A1.2 Fire Alarm and Sprinkler Systems

A1.2.1 *Fire* alarm systems used in *fire safety precautions* Types 2 to 7 shall satisfy all the requirements of F7/AS1. *Fire* sprinkler systems used in the *fire safety precautions* Types 6 and 7 shall also satisfy all the requirements of Appendix D.

A1.3 Requirements Common to Alarm System Types 2 to 7

A1.3.1 Except for Type 1 Systems, each *fire* alarm system, regardless of method of activation, shall be provided with a means of communication with the Fire Service in accordance with F7/AS1 Paragraph 2.2.

A2.1 FSP Descriptions

A2.1.1 The following text provides a brief description of each *FSP*. More detailed information is supplied in F7/AS1 for Types 2 to 7.

Type 1 Domestic Smoke Alarm System

A stand-alone domestic/residential type automatic smoke detection and alarm system with limited coverage that activates automatically in the presence of smoke. This system **may** be battery powered and has detectors and alerting devices. The system is restricted to a single *firecell* and does not have a connection to the Fire Service or an indicating unit.

COMMENT:

This system is for use only within *household units*, and is intended to provide early warning to the occupants.

Amend 2
Apr 2003

Type 2 Manual fire alarm system

An alarm system which is activated only by someone operating a manual call point. It is a single or multiple zone system with an alarm panel providing a zone index diagram and defect warning, and suitable for connection to the Fire Service.

Type 3 Automatic fire alarm system activated by heat detectors and manual call points

A detection and *fire* alarm system, which activates automatically when a pre-determined temperature is exceeded in the space, and can be activated manually at any time.

Type 4 Automatic fire alarm system activated by smoke detectors and manual call points

A detection and *fire* alarm system which activates automatically in the presence of smoke, and can be activated manually at any time. Type 5 is an optional alternative to this system for *purpose groups* SA and SR.

COMMENT:

Smoke detectors should not be located in spaces where the activity within that space (e.g. a kitchen or smokers bar) is likely to initiate a false alarm. See F7/AS1 for alternative systems.

Type 5 Automatic fire alarm system with modified smoke detection and manual call points

A variation of the Type 4 and Type 7 alarm systems requiring part of the smoke detection component to comprise only a local alarm.

The local alarm system, activated by the presence of smoke, has audible alerting devices to warn only the *firecell* occupants and the *building* management, where such management exists. Examples of such management situations are motels, hotels or multi-unit residential accommodation in a retirement village.

Amend 7
Nov 2008

Amend 2
Apr 2003

Amend 2
Apr 2003

The local alarm component of a Type 5 system:

- a) Is restricted to single *firecells* containing sleeping accommodation being *household units* in *purpose group* SR or individual *suites* in *purpose group* in SA. The local alarm system shall not be extended to other areas such as *exitways* or common spaces. These shall retain a Type 4 smoke detection system, and
- b) Shall have the facility to be silenced (muted) by a 'hush' switch located at an accessible level in accordance with D1/AS1 (section 7). The hush switch shall mute the alarm for a time not exceeding 2 minutes, and
- c) Shall be permitted only where an automatic *fire* detection and alarm system activated by heat detectors (part of the main alarm system) is also installed in sleeping *firecells* which do not already have an automatic sprinkler system.

Where a Type 5 system is installed, mechanical extract ventilation in accordance with G4/AS1 shall be provided in the kitchen area of the *household unit*.

In *exitways* and common spaces the required Type 4 or Type 7 system shall not be modified. The system installation for Type 3 and Type 4 components shall comply with NZS 4512.

Type 6 Automatic fire sprinkler system with manual call points

An automatic *fire* detection, alarm and control system which, when a specified temperature is exceeded in the space, activates the sprinkler head in the affected area and includes alerting devices throughout the *building*. The system permits alerting devices to be activated manually.

Type 7 Automatic fire sprinkler system with smoke detectors and manual call points

An automatic *fire* alarm system having the same characteristics as a Type 6 alarm plus an automatic smoke detection system. The *fire*

alarm signal resulting from smoke detection need not be directly transmitted to the Fire Service.

A Type 5 alarm is an optional alternative in SA or SR *purpose groups* for part of the smoke detection component of the Type 7 system. (Refer to Type 5 above for specific requirements.)

COMMENT:

Smoke detectors are used to gain an earlier warning to life threatening situations than may be achieved from the response of sprinklers, particularly where a smouldering *fire* does not produce enough heat in its early stages to activate a sprinkler head.

Type 8 Voice communication system

An automatic system with variable tone alerting devices, the facility to deliver voice messages to occupants, and to allow two-way communication between emergency services personnel.

Voice communication systems shall comply with AS 2220: Parts 1 and 2.

COMMENT:

A voice communication system, particularly in tall *buildings*, permits controlled evacuation. In cases where the sprinkler system and Fire Service achieve early control of the *fire*, it may be necessary to evacuate only part of the *building*.

Type 9 Smoke control in air-handling system

Heating, ventilating or airconditioning systems if installed in *buildings*, shall comply with the requirements for smoke control in Part 6.

These shall be installed with either:

- a) Self contained detection, control and provision of output signal/alarm generally to comply with AS/NZS 1668: Part 1 and interface with any Type 3, 4, or 7 system installed, or
- b) *Fire* alarm and warning systems Type 3, 4 or 7 as a means of smoke detection, in accordance with NZS 4512 to provide ancillary function output for control of the *HVAC* system.

Amend 7
Nov 2008

Amend 7
Nov 2008

Type 10 Natural smoke venting

This is a method of smoke extraction where a *firecell* is provided with a smoke reservoir, and with outlet vents and fresh air inlets which open automatically when actuated by the smoke detection system. Smoke movement is by natural draught.

Type 10 requirements apply only to the common space (such as an atrium) in *firecells* with *intermediate floors*.

COMMENT:

These systems are used in *firecells* with *intermediate floors* and having an *occupant load* which is not great enough to justify a mechanical extraction system. Requirements for smoke reservoirs and natural smoke ventilation systems are given in Paragraphs 6.22.8 to 6.22.10.

Type 11 Mechanical smoke extract

Mechanical smoke extract uses fans in place of the natural draught relied upon in Type 10. The *firecell* shall have smoke reservoirs. The system shall comply with the requirements of Paragraphs 6.22.8 c), 6.22.9 and 6.22.11 to 6.22.14. Type 11 requirements apply only to the common space in *firecells* with *intermediate floors*.

Type 12 Deleted

Type 13 Pressurisation of safe paths

Pressurisation methods and installation shall comply with AS/NZS 1668: Part 1 Section 9. The system shall be automatically activated by smoke detectors, and shall keep the *safe paths* free of smoke for sufficient time to allow occupants to reach a safe place, and in no case for less than 60 minutes.

COMMENT:

1. AS/NZS 1668 gives airflow speed and pressure requirements which ensure effective pressurisation without causing occupants to have difficulty opening doors.
2. Pressurisation is generally necessary only for vertical *exitways* where the *escape height* exceeds 25 m.

Type 14 Fire hose reels

Fire hose reels shall comply with AS/NZS 1221, and the distribution, installation and maintenance with NZS 4503, except that the maximum hose length shall be 36 m. *Fire* hose reels shall not be installed in vertical safe paths.

COMMENT:

Fire hose reels are required primarily for use by the New Zealand Fire Service and also for situations where they may be operated by people experienced in their use.

Type 15 Fire Service lift control

The Fire Service lift control where required, shall enable the Fire Service to have exclusive use of any lift for *fire* fighting purposes. Once a Type 15 *FSP* is required for any level in a *building*, it shall be applied to all levels.

COMMENT:

A first priority of the Fire Service is to assist with the evacuation of non-ambulant occupants, and to locate any occupants who may be trapped. In multi-floor *buildings*, lifts can greatly reduce the time taken to accomplish these tasks.

Type 16 Visibility in Escape Routes

Visibility in *escape routes* is specified in NZBC Clause F6.

Visibility in *escape routes* requirements for *purpose group CO* (which is not included in Table 4.1) shall be as for *purpose groups CS* and *CL*.

Amend 7
Nov 2008

Type 17 Emergency electrical power supply

The emergency power supply is necessary to ensure the continued operation during evacuation, of essential equipment such as smoke control systems, emergency lighting and lifts. Detailed requirements are given in Paragraph 6.23.3. The requirement applies generally to tall *buildings* having sleeping accommodation or crowds (see Table 4.1 for specific situations).

Type 18 Fire hydrant system

Fire hydrant systems shall comply with NZS 4510 "Fire hydrant systems for buildings". Once a Type 18 *FSP* is required for any level in a *building*, it shall be applied to all levels.

Type 19 Refuge areas

Refuge areas are required within *safe paths* in tall *buildings* where congestion is likely to occur. They also provide an opportunity for slow moving occupants to rest without constricting the movement of others. The locations and sizes of refuge areas are given in Paragraph 3.13.

Type 20 Fire systems centre

A facility for Fire Service use which shall:

- a) Be readily accessed from street level and located in a position to be determined in consultation with the New Zealand Fire Service,
- b) Be protected from the effects of *fire* including debris falling from an upper floor, and
- c) Contain all control panels indicating the status of *fire* safety systems installed in the *building*, together with all control switches.

Appendix B: Testing of Smoke Control Systems

B1.1 General

B1.1.1 To ensure their effective operation, smoke detection, warning and control systems, and pressurisation systems shall be tested before occupation of the *building*, and annually thereafter.

Amend 7
Nov 2008

During the planning stage, agreement shall be reached with the *building consent authority* and the method to be used for determining the acceptability of the smoke control system shall be documented.

B2.1 Pre-occupancy Test

B2.1.1 The following procedure shall be observed:

Step 1 Individually test every component of the system to prove their correct operation. When the performance of every component has been satisfactorily proven, proceed to Step 2.

Step 2 Choose sufficient *fire* scenarios to cover all likely *fire* origin locations, then with all systems on line, test each one in turn by artificially activating a detector.

When proof is obtained that all systems will act in concert as part of the total smoke control system and on each *fire* scenario, proceed to Step 3.

Step 3 Determine from Step 2 the most complex *fire* location(s) with respect to smoke/fresh air movement, *escape routes* etc, and for each location, subject the system to a hot smoke test and record the results.

Amend 7
Nov 2008

Prior agreement shall be reached with the *building consent authority* on the parameters to be used for acceptance of satisfactory performance.

COMMENT:

1. This is one suggested method of determining compliance with the original agreed design, based on a three stage check.
2. Step 1 would include smoke extraction systems, make-up air supply, smoke detectors and alarms, HVAC components where appropriate, automatic door closers, door *hold-open devices* if any, pressurisation systems, and emergency power supply where installed.
3. For Step 2 not only must each system be seen to operate as designed, but the design assumptions must be confirmed.
4. Each test is to be recorded, together with the response of all associated components being checked for integration with the total system via the control matrix, under normal power supply, and, if installed, under emergency power supply. Proof must be obtained that all systems will act in concert as part of the total smoke control system for each *fire* scenario.
5. For Step 3 the lighting of *fires* in near-complete *buildings* presents obvious problems. Operational testing of individual systems is not sufficient proof of the whole system. Cold smoke tests are inadequate because they do not simulate the buoyant behaviour of real smoke. Useful results can be obtained by generating artificial "fog" and passing it over a liquid fuel *fire*. Parameters for smoke tests may include visual observation of smoke clearance behaviour and of the visibility of exits and exit signs within a time scale considered acceptable for escape into the protection of *exitways*.
6. For a complex *fire* safety system it is vital to ascertain whether the system will operate in the best interests of the occupants.
7. Operational tests of individual components and systems are not sufficient to prove the whole system. It is seldom feasible during acceptable testing to produce the heat and smoke for which the installation is designed. Generally hot smoke testing can be done without damage to *surface finishes* using a heat source of about 0.5 MW and a smoke generation of about 3 m³/s.

B3.1 Annual Testing

B3.1.1 For each of the critical scenarios selected in Step 2 of the pre-occupancy test, smoke control and extraction systems shall be tested by activating one of the smoke detectors, and recording the results. Those results shall be compared with results of the pre-occupancy tests, with any necessary adjustments then being made to bring the systems to full operational standard.

B4.1 Small Firecells

B4.1.1 Where a *firecell* has an *occupant load* of no more than 100, and no more than two *intermediate floors*, test procedures may be restricted to a smoke test capable of verifying detector operation and automatic actuation of vent opening mechanisms.

Appendix C: Test Methods

C1.1 General

C1.1.1 This Appendix contains test methods for confirming that specific *building elements* satisfy relevant provisions of the Fire Safety Approved Documents. It includes both established *standard tests* and other test methods for *building elements* in situations where *standard tests* are unavailable.

C2.1 Flammability of Floor Coverings

C2.1.1 Materials shall be classified according to BS 5287 when tested to:

BS 4790 Method for determination of the effects of a small source of ignition on textile floor coverings (hot metal nut method).

Amend 7
Nov 2008

C3.1 Flammability of Suspended Flexible Fabrics and Membrane Structures

C3.1.1 Materials shall be assigned a *flammability index* when tested to:

AS 1530 Methods for fire tests on building materials and structures – Part 2: Test for flammability of materials.

Amend 7
Nov 2008

Amend 7
Nov 2008

C4.1 Properties of Lining Materials

Amend 7
Nov 2008

C4.1.1 Materials shall be assigned:

- a) An *ignitability index*,
- b) A *spread of flame index*,
- c) A heat evolved index,
- d) A *smoke developed index*,

when tested to:

AS/NZS 1530 Methods for fire tests on building materials, components and structures – Part 3: Simultaneous determination of ignitability, flame propagation, heat release and smoke release.

C5.1 Non-combustibility of Materials

Amend 7
Nov 2008

C5.1.1 Materials shall be classified as *non-combustible* or *combustible* when tested to:
AS 1530 Methods for fire tests on building materials and structures – Part 1:
Combustibility test for materials.

C6.1 Fire Resistance

Amend 7
Nov 2008

C6.1.1 *Primary* and *secondary elements*, closures and *fire stops* shall be assigned a *fire resistance rating (FRR)* when tested to:

AS 1530 Methods for fire tests on building materials and structures – Part 4: Fire resistance tests of elements of building construction; or

NZS/BS 476 Fire tests on building materials and structures – Parts 20 to 22. Test methods for determining the fire resistance of elements of construction.

Amend 7
Nov 2008

C6.1.2 *Fire stops* shall be tested:

- a) In circumstances representative of their use in service, paying due regard to the size of expected gaps to be stopped, and the nature of the *fire separation* within which they are to be used, and
- b) In accordance with AS 4072: Part 1, Service penetrations and control joints.

C7.1 Fire Resisting Closures and Smoke Control Doors

Amend 7
Nov 2008

C7.1.1 *Fire resisting closures* shall be evaluated in circumstances representative of their use in service, and shall comply with NZS 4520 Fire-resistant doorsets.

Amend 9
Oct 2011

Frictional forces

Amend 7
Nov 2008

C7.1.2 The forces required to open any *fire door* or *smoke control door*, on an *escape route*, shall not exceed 67 N to release the latch, 133 N to set the door in motion, and 67 N to open the door to the minimum required width. These forces shall be applied at the latch stile. These requirements do not apply to horizontal sliding doors in *SD purpose group*, or power-operated doors.

Amend 7
Nov 2008

C7.1.3 *Smoke control doors* shall comply with Paragraphs C7.1.4 to C7.1.6.

Self-closing provision

Amend 7
Nov 2008

C7.1.4 As required by Paragraph 3.17.1:

- a) All door leaves shall be self-closing, and
- b) Provision shall be made for the self-closing device to be adjustable during commissioning to satisfy the requirements of Paragraph C7.1.2 after installation.

Amend 7
Nov 2008

C7.1.5 Where it is desirable in normal circumstances for a *fire door* or *smoke control door* to operate freely, it is acceptable to use a self-closer mechanism which activates in the event of *fire* but does not operate at other times.

COMMENT:

1. These circumstances can occur where people are under care. Leaving the door to the occupant's room (or *suite*) open, reduces that occupant's feeling of isolation and permits ready observation by staff.
2. Self-closers can be an obstruction to the elderly and *people with disabilities*, who have difficulty in opening the door against the pressure applied by the self-closer.

Automatic smoke-sensing devices

C7.1.6 Automatic smoke-sensing devices complying with NZS 4512, if used, shall be positioned within the stream of air that passes the door opening when the *smoke control door* is fully open.

Amend 7
Nov 2008

C8.1 Fire Properties of External Wall Cladding Systems

C8.1.1 *Fire* properties of *external wall* cladding systems shall be determined in accordance with:

AS/NZS 3837 Method of test for heat and smoke release rates for materials and products using an oxygen consumption calorimeter.

Amend 7
Nov 2008

C8.1.2 In addition to meeting the general requirements of AS/NZS 3837, testing shall also be in accordance with the following specific requirements:

- a) An applied external heat flux of 50 kW/m²,
- b) A test duration of 15 minutes,
- c) The total heat release measured from start of the test,
- d) Sample orientation horizontal, and
- e) Ignition initiated by the external spark igniter.

Amend 7
Nov 2008

C8.1.3 *External wall* cladding systems, which comprise only materials which individually are classified as *non-combustible*, may be deemed to satisfy all the requirements of Table 7.5.

Amend 7
Nov 2008

COMMENT:

The *non-combustible* classification represents a more onerous performance level than those required by Table 7.5, and is therefore acceptable. A *non-combustible* classification may be claimed only if the respective materials have been subjected to testing as described in Paragraph C6.1.

Amend 7
Nov 2008 | **C8.1.4** Claddings incorporating a metal facing with a melting point of less than 750°C covering a *combustible* core or insulant shall be tested as described in Paragraph C8.1.2 without the metal facing present.

COMMENT:
Aluminium has a melting point less than 750°C.

C9.1 Flame Barriers

Amend 7
Nov 2008 | **C9.1.1** An assembly incorporating the *flame barrier*, and any proposed jointing methods in that barrier, shall be subjected to the *standard test* for *fire* resistance (Paragraph C6.1.1) for a period of at least 10 minutes. The size of the test specimen shall be in accordance with the *standard test* for *fire* resistance. At the completion of the test, the exposed face of the *flame barrier* shall be inspected.

Amend 7
Nov 2008 | **C9.1.2** The *flame barrier* shall pass the test if no cracks, openings or other fissures have developed which would permit vision through the *flame barrier* or joint. This inspection may, at the discretion of the test laboratory, be made during the process of the *standard test* for *fire* resistance if an *adequate* assessment can be made of the heated face of the specimen after 10 minutes duration.

COMMENT:
This test differs from the *standard test* for *fire* resistance. In the *standard test*, criteria for *integrity* and temperature rise across the test specimen, are applied to the complete *building element* assembly. For a *flame barrier*, the criteria are applied only to the barrier material protecting the other components of the assembly.

Amend 7
Nov 2008 | **C9.1.3** A *flame barrier* achieving a thermal barrier index of no less than 10, when tested to Uniform Building Code Standard 26-2, need not comply with Paragraphs C9.1.1 and C9.1.2.

Appendix D: Fire Sprinkler Systems

D1.1 Introduction

D1.1.1 Wherever sprinklers are required by this acceptable solution, they shall comply with the relevant New Zealand Standard, amended as shown in Paragraphs D2.1 and D3.1.

D1.1.2 When referring to NZS 4541 it should be noted that a single Class C1 Water Supply is the only supply required for compliance with the New Zealand Building Code.

Amend 8
Sep 2010

Clause 1203 ROUTINE SURVEYS

Clause 1203.1 It is important that a sprinkler system at all times complies with this Standard as amended by Paragraph D2.1 of Appendix D to C/AS1 in all respects. To ensure that *building alterations*, changes in process or storage patterns or progressive deterioration of system components do not prejudice system compliance, a comprehensive survey shall be carried out biennially at intervals not exceeding 28 months. Such surveys shall be carried out by an independent qualified *person*.

D2.1 Automatic Fire Sprinkler Systems

D2.1.1 NZS 4541: 2007 is amended as follows:

Amend 4
Oct 2005

Clause 103 DEFINITIONS

Sprinkler system A system including:

- (a) to (i) No change.
- (j) Delete.
- (k) Delete.
- (l) No change.

Amend 4
Oct 2005

Amend 7
Nov 2008

Amend 4
Oct 2005

Amend 7
Nov 2008

Amend 4
Oct 2005

Clause 205 Delete entire clause.

Clause 208 Delete entire clause.

Amend 7
Nov 2008

Amend 4
Oct 2005

Amend 4
Oct 2005

D3.1 Residential fire sprinkler systems

Amend 4
Oct 2005

D3.1.1 NZS 4515: 2003 is amended as follows:

Clause 1.3 Definitions

Sprinkler system A system including:

(a) to (g) No change.

Amend 4
Oct 2005

(h) Delete.

Amend 4
Oct 2005

Clause 1.9 Delete entire clause.

Clause 2.1.2 Delete.

Clause 2.1.3 Delete.

Amend 4
Oct 2005

Index C/VM1 & C/AS1

References are to the relevant paragraphs, figures or tables in **C/AS1** unless otherwise stated. References to Appendices are prefixed by the Appendix letter.

	Air ducts	6.9.5, 6.19.14, 6.20.20, 6.20.21
	Aprons	7.9.12, 7.9.13, Figure 7.2
	Balconies	3.14.6 b), 3.14.7, 3.15.7, 7.8.7, Figures 3.18, 3.22
	Basements	3.3.2 i), 3.7.1, 3.15.2, 4.5.15, 6.9.3, 6.14.4, Figure 3.19
	Building elements	5.1.1, 5.2.1, 5.6.1
Amend 4 Oct 2005	primary	5.1.1, 5.3.1, 5.3.2 a) c), 5.6.1 a), 5.7.1, 5.7.4, 5.7.7, 5.7.8, 5.9, 6.14.3, 7.1.2 b), 7.8.10 b), 7.9.4, 7.9.5, 7.10.3, 7.10.4, C7.1.1
Amend 4 Oct 2005	secondary	5.1.1, 5.3.1, 5.3.2 b), 5.6.1 a), 5.7.1, 5.7.8, 7.1.2 b), 7.10.2, C7.1.1
	unrated primary	5.9.4, Figure 5.2
	Building height	5.7.6 c), 7.11.3, 7.11.4
	Buildings	
	air-supported structures	6.20.18
	atriums	6.22
	car parking	6.8.4, 6.10.3 to 6.10.6, 7.8.2, 7.9.16, Figure 6.2
	carports	7.8.10
	dwellings	
	attached and multi-unit	1.3.5, 1.3.6
	detached	1.3.3
	education	3.8.4, 6.20.7
	grandstands	3.16.7
	hospitals	6.6.6
	hotels, motels and accommodation	2.2.3
Amend 7 Jun 2008	membrane structures	6.20.17 to 6.20.19, C3.1.1
	multi-storey buildings	2.2.5, 6.12.2
	open air auditoriums	3.16.5
	open sided buildings	7.8.8 to 7.8.10, Figure 7.10
	purpose group classification	2.2, Table 2.1
Amend 4 Oct 2005	remaining occupied during fire	5.6.9
	residential community care	2.4
	taverns	2.2.3
	theatres	6.3.1, 6.19.9, Figure 6.13
	wharehousi	3.3.2 h), 3.4.2 e), 6.7.9
Amend 3 Feb 2004	Chimneys	9.5, Figures 9.1, 9.2, 9.3

Concealed spaces 6.18.1, 6.18.10
 cavity barriers 6.18.1, 6.18.4 to 6.18.6
 ceiling space firecells 6.12.8
 ceiling space restrictions. 6.18.7 to 6.18.10
 in walls and floors 6.18.4
 within firecells. 6.18.2, 6.18.3, Figure 6.10

Corridors 6.13.1, Figure 6.5

Dead ends See Escape routes

Doors and doorsets 3.9.1, 3.11.6, 6.19.4
 acceptable obstructions 3.3.6 e)
 accessible escape routes 3.3.7
 automatic sliding doors. 3.17.7
 closers and latching 3.17.1
 degree and width of opening 3.17.4, 3.17.5
 delayed action unlocking devices 3.17.11
 direction of opening 3.17.3, 3.17.4
 door swings. 3.4.5 b), 3.13.2, 3.17.5 d) e)
 fire doors. 3.3.1 b), 3.6.1 c), 3.11.9, 3.17.9, 3.17.13, 6.19.2 a),
 C7.1, Figures 3.29 to 3.31, Table 6.1
 glazing 5.8.10, 5.8.11
 hold-open devices 3.17.1 b), 3.17.9, 3.17.10
 lift landing doors 6.16.5 b), 6.19.13, Table 6.1
 locking devices 3.17.2, 3.18.6
 markings 6.19.6, 6.19.7
 panic bolts. 3.17.14
 revolving doors, automatic doors and
 access control systems 3.17.7, 3.17.8, Figure 3.26
 signs 3.20.1
 smoke control doors 3.17.9, 3.17.12, 6.9.11, 6.19.2 b), C7.1,
 Figures 3.27, 3.28, 6.1, Table 6.1
 subdividing escape routes 3.17
 vision panels 3.17.6, 5.8.10

Downlights 9.4

Early childhood centres 3.5.4, 3.18.1, Tables 2.1, 4.1

Enclosing rectangles 7.3.6, 7.5, 7.6
 buildings on sloping sites and buildings of
 irregular height. 7.5.9, 7.5.10, Figure 7.7
 exceptions for SH, SR and SA buildings. 7.5.7, 7.5.8, Figure 7.7
 Method 2. 7.3.4 a), 7.3.6 to 7.3.8, 7.3.12, 7.5,
 Figures 7.5 to 7.7, Table 7.2
 Method 3. 7.3.4 b), 7.3.8, 7.3.12, 7.6, Figure 7.8
 Method 4. 7.3.4 c), 7.3.9, 7.7, Figure 7.9, Tables 7.3, 7.4

Escape height 2.2.9 a), 3.3.4, 3.15.3 a), 3.15.6, 3.15.7 a), 3.18.1,
 4.5.10 b), 5.3.2 c), 7.9.10, Figure 3.20, Table 4.1

Amend 7
Nov 2008 |

Amend 7
Nov 2008 |

Amend 3
Feb 2004 |

Amend 4
Oct 2005 |

Amend 4
Oct 2005 |

	Escape routes	3.1 to 3.4, 3.6.1, 3.7.1, 3.9.12 to 3.9.14, 3.11.4, 3.17.3, 3.17.5, 4.5.7, 7.10.3, Figures 3.1 to 3.5, Tables 3.1, 3.2
Amend 4 Oct 2005	accessible	3.3.7, 3.17.5 a)
	doors subdividing escape routes	3.17
Amend 4 Oct 2005	exitways	3.3.2 a), 3.11, 3.12, 6.9, 6.16.6, A2.1.1 Type 16, Figures 3.3, 3.20, Tables 2.1, 6.1 to 6.3
Amend 4 Oct 2005	external exitways.	3.16.4, 5.6.4 c), 7.9.1, 7.9.3
	lighting	3.19.1
	lighting for emergency.	see Fire safety precautions
	pressurisation	see Fire safety precautions
	split level exitways	3.15.8, Figure 3.24
	ventilation of enclosed exitways	6.9.6 to 6.9.10
	external	3.14
	handrails	3.3.3, 3.3.6 b), 3.9.8, 6.20.4 c)
	height and width of escape routes	3.3
	height.	3.3.1
	width	3.3.2 to 3.3.5, 3.9.4 to 3.9.6, 3.9.12 e), 3,17.5, Figures 3.3, 3.4, 3.6, Tables 3.2, 3.4
	length of escape routes	3.4, 3.5, 3.11.7, 6.13.1, Figures 3.7, 3.9, 3.10, Table 3.3
	number of escape routes	3.2, Figure 3.2, Table 3.1
	obstructions	3.3.6, 3.4.2 c), 3.17.5 a) e), 3.18.3
	access control systems.	3.17.7
	chains.	3.3.6
	crowd control barriers	3.3.6
	sliding bars.	3.3.6
	turnstiles	3.3.6
	open paths	2.2.8, 3.1.2, 3.1.3, 3.1.5, 3.3.2 f), 3.3.7, 3.4.1, 3.4.2, 3.8, 3.9, 3.17.3 a), 3.17.5 a), A2.1.1 Type 16, Figures 3.1, 3.7, 3.9, 3.12, 3.16, Table 3.3
	dead end open paths.	1.3.4 Step 2, 3.3.2 b), 3.4.2, 3.5.1, 3.10, 3.14.4, Table 3.3
	increases in open path lengths	3.5
	intermediate floors.	3.3.2 f), 3.4.1 a), 3.4.6, 3.9.13, Figure 3.9
	length.	1.3.4 Step 2, 2.2.8, 3.1.3, 3.4.1, 3.4.2, 3.4.4, 3.4.6 to 3.4.8, 3.5, 3.15.1, Figures 3.7, 3.9, Table 3.3
	number of open paths.	3.8.1
	ramps.	3.1.4, 3.9.2, 3.14.7
	separation of open paths	3.8.3, Figure 3.12
	size of open paths.	3.8.1
	sloping floors and ceilings.	3.4.8
	special cases.	3.9

Escape routes *(continued)*

- aisles 3.9.4 to 3.9.9, Figure 3.15
- exception for education buildings 3.8.4
- fixed seating 3.9.3, Figures 3.13 to 3.15, Table 3.4
- ladders 6.4.7 c), 3.10.2
- long corridors 6.13, Figure 6.5
- loose seating 3.9.10, 3.9.11
- separate tenancies 3.9.1
- subdivision 6.13.1 a)
- unenclosed stairs 3.9.14
- protected paths 3.1.2, 3.7.1 a), 3.9.12, 3.9.13, 3.11.1, 3.11.2,
3.15.3 b), 3.16.3, 6.9.1, 6.9.6 a), 6.10.4 a),
6.11.3 b), Figures 3.1, 3.7, 3.8, 3.11, 3.19,
3.28, 3.30, Tables 2.1, 6.1
- floor area 3.4.3, 3.4.5
- length 3.1.3, 3.4.1, 3.4.4, 6.13.1 a), Table 3.3
- subdivision 6.13.1 a)
- safe paths 3.1.2, 3.4.1 b), 3.7.1, 3.9.14, 3.11.4 to 3.11.6,
3.11.9, 3.14.1, 3.15.3 b), 3.15.6,
3.15.8 a), 3.16.1, 3.16.6, 3.16.8,
3.16.9, 6.9.2 to 6.9.4, 6.10.4 a), 6.22.2 d),
7.2.1 b), 7.7.1, A2.1.1, Type 13, Type 19,
Figures 3.1, 3.8, 3.16, 3.19, 3.21, 3.22, 3.24,
3.29 to 3.31, 5.1, Tables 2.1, 6.1, 7.4
- glazing 5.8, Figure 5.1
- horizontal safe paths 3.11.6 a), 3.11.7, 3.11.8,
3.17.9 b), 3.17.13 e), 6.9.8
- length restrictions 3.11.7, 3.15.5 c)
- permitted activities 3.12.2
- subdivision 6.13.1 a)
- vertical safe paths 3.11.6 b), 3.11.7, 3.12.3,
3.13, 3.16.3, 3.17.9 b),
3.17.12 a), 3.17.13 e), 6.9.7, 6.9.11,
A2.1.1 Type 14, Figure 6.1
- signs 3.20
- single escape routes 3.15, Table 4.1 special application b
- active purpose groups 3.15.3, 3.15.4
- basements 3.15.2, Figure 3.19
- bridges 3.15.7, Figure 3.23
- external balconies 3.15.7, Figure 3.22
- external stairways 3.15.7
- intermediate floors 6.22.2 c)
- internal stairs 3.15.6, Figure 3.21
- sleeping purpose groups 3.15.5, Figure 3.21
- split level exitways 3.15.8, Figure 3.24
- stairs 3.15.6, 3.15.7, Figures 3.21 to 3.23
- surface finishes 3.3.2 h), 3.4.2 e), Table 6.2

Escape through adjacent firecell 3.9.12, Figure 3.16

Escape through adjoining buildings. 3.6, Figure 3.11

External walls 3.14.3, 3.14.5, 3.14.6, 5.7.5, 5.7.6,
6.12.7, 7.1.1, 7.3, 7.4.1, 7.5 to 7.7, 7.8.7, 7.9.7,
7.9.10, 7.9.11, 7.10, 7.11.2, D2.1.1 Clause 511.7.3,
Figures 6.11, 6.12, 7.1, 7.3, 7.11, Table 7.5

 cladding 7.9.18, 7.11.2, 7.11.3, C9.1, Table 7.5

 fire resistance ratings 3.14.5, 3.14.6, 5.7.5, 5.7.6, 7.3.10, 7.4.3,
7.8.3 to 7.8.5, 7.8.10 c), 7.9.9, 7.9.16, 7.10

 firecell separation 7.3, 7.8 to 7.10, Figures 7.1 to 7.12,
Tables 7.1 to 7.4

 glazing 7.3.3 c), 7.3.5 to 7.3.7, 7.4, Figure 7.4
Table 7.1

Amend 4 | return walls 7.3.3 e), 7.3.9, 7.7, 7.10.4,
Oct 2005 | Figure 7.9, Tables 7.3, 7.4

Amend 4 | surface finishes 7.1.2 c), 7.11.2 to 7.11.4
Oct 2005 | wing walls 7.3.3 d), 7.3.9, 7.7, 7.10.4, Tables 7.3, 7.4

F rating see Fire resistance ratings

FHC. see Fire hazard category

FI see Flammability index

Final exits 3.1.2, 3.1.3, 3.14.5, 3.16.4, 3.17.1 c),
3.18.1, 6.20.18 a), Figures 3.1, 3.2, 3.12,
3.19, 3.24, 3.31, Table 6.1

Fire alarm systems see Fire safety precautions

Fire fighting facilities 8.2

Fire hazard category (FHC) 1.3.2 Step 3, 2.2.1, 3.12.2 d), 3.12.3 c),
3.15.2 b), 3.15.3 a), 4.2.3, 5.4.1 f) j), 6.6.7, 6.20.7,
6.20.15 a), 6.21.5 a), 6.22.1, 7.1.3, 7.3.2 b), 7.5.2,
7.5.3 Step 4, 7.7.5 Step 5, 7.8.1, 7.8.2,
7.8.9 c) d), 7.9.8 b), 7.10.6 a), Figures 3.19, 3.20,
7.1, 7.10 Note 3, Tables 2.1, 5.1, 7.1 to 7.4

Amend 4 | category 4 buildings 2.2.10, 5.6.11 to 5.6.13,
Oct 2005 | 7.8.1, 7.8.2, Table 2.1

Fire load energy density (FLED) 2.2.1 Comments, 2.2.10, Table 5.1

Fire resistance ratings (FRR) 1.3.2 Step 8, 1.3.4 Steps 4 and 6,
1.3.5 b), 3.6.1 c), 3.14.6 c), 3.15.3 c), 3.16.6, 4.1.2,
4.3.2, 5.1, 5.2, 5.9.5 a) b), 5.9.6, 6.2.1, 6.3.1, 6.6.1, 6.6.2,
6.6.5 to 6.6.7, 6.7.1, 6.7.2, 6.7.5, 6.7.6, 6.8.1, 6.9.2,
6.9.3, 6.10.1, 6.10.2, 6.10.5, 6.11.1, 6.12.1, 6.12.6, 6.14,
6.15, 6.16.2, 6.16.3, 6.17.2, 6.18.8, 6.19.14, 7.2.1, 7.4.3,
7.8.1 a), 7.8.2 to 7.8.6, 7.8.10 b) c), 7.9.3, 7.9.4,
7.9.8 b), 7.9.13, 7.10, C6.1.1, Figure 7.10, Table 6.1

Amend 4 Oct 2005 | application of F and S ratings 5.3
applying FRRs to building elements 5.7

Amend 4 Oct 2005 | concessions for multiple purpose groups 5.6.7, 5.6.8
determining F and S ratings 5.4, 5.5
determining the FRR 5.6
firecell rating (F) 3.16.6, 4.1.2, 4.3.2, 4.4.1 Step 5, 4.5.7,
4.5.14, 5.2.2, 5.3.1, 5.3.2, 5.4, 5.5.1,
5.6.7 a), 6.15.1, 6.16.2, 6.16.3, 6.20.15,
7.2.1 a), 7.10.2, 7.10.3, Table 4.1

Amend 4 Oct 2005 | firecells rated F0 6.2
fire resistance tests 5.9.6, C6.1.1

Amend 4 Oct 2005 | floors 3.14.6 c), 3.15.3 c), 4.3.2, 5.6.4 d), 5.7.3,
6.10.3, 6.14, 6.15, 7.8.6

insulation rating 5.1.1 c), 5.6.3 to 5.6.5, 5.8.10, 6.19.13,
7.8.1 a), Table 6.1 Notes

integrity rating 5.1.1 b), 5.6.5, 5.8.2, 7.4.3

intermediate floors 4.5.16, 6.14.3

minimum FRRs 5.7.9

open sided buildings 7.8.10 b) c), Figure 7.10

Amend 4 Oct 2005 | reductions for sprinklered firecells 5.6.6

Amend 4 Oct 2005 | roofs 7.8.1, 7.9.3, 7.9.8 b), Figures 7.1, 7.11

Amend 4 Oct 2005 | small buildings 7.10.5

stability rating 5.1.1 a), 5.6.5, 5.9.4, 5.9.5

structural fire endurance rating (S) 2.2.10, 4.1.2, 4.2.3, 5.2.2,
5.3.2, 5.4, 5.5.2, 5.5.3, 5.6.5, 5.6.9 a),
5.6.11, 6.10.5, 7.2.1, 7.4.3, 7.8.1 a), 7.8.5,
7.8.6, 7.10.2, 7.10.5, 7.10.8, Table 5.1

Amend 7 Nov 2008

Amend 7 Nov 2008

Amend 7 Nov 2008

Fire resisting closures 6.18.9, 6.19, C6.1.1, C7.1.1, Table 6.1

access panels 6.19.12

fire curtains 6.19.9, 6.19.10

fire dampers 6.3.2 f), 6.16.5 d), 6.19.14

fire doors see Doors

fire shutters 6.19.15 to 6.19.17

lift landing doors see Doors

smoke control doors see Doors

	Fire safety precautions (FSP)	1.2.3, 1.3.2 Step 6, 2.3.1, 3.1.5, 4.2.6, 4.2.7, 4.3.1, 4.4.1, 4.5, 5.6.8, 6.10.1, 6.11.1, Appendix A, Table 4.1
Amend 4 Oct 2005	automatic fire alarm system with modified smoke detection and manual call points (Type 5)	3.5.4, 4.5.4, 4.5.10, Table 4.1
Amend 7 Nov 2008	domestic (Type 1)	A2.1.1
Amend 2 Apr 2003	emergency electrical power supply (Type 17)	6.23.1 d), 6.23.3, 6.23.4, A2.1
	emergency lighting (Type 16)	3.19.2, 6.23.3 c), 6.23.4, A2.1
	fire hose reels (Type 14)	8.2.2, A2.1
	fire hydrant systems (Type 18)	8.2.1, A2.1
	Fire Service lift controls (Type 15)	8.2.5, A2.1
	fire sprinklers (Type 6)	3.9.12 f), 3.15.3 a), 3.15.6, 3.15.7 a), 4.1.1 a), 4.5.10, 4.5.11, 5.6.12, 6.3.2 a) d), 6.6.8, 6.16.8, 6.18.10, 6.19.9, A2.1, Appendix D, Figure 7.2
Amend 4 Oct 2005	concessions for sprinklers	3.3.2 c), 3.4.8 d), 3.5.2, 3.14.3, 3.15.3 a), 3.15.6, 3.15.7 a), 3.16.3 b), 4.2.5, 5.5.3, 5.6.6, 5.6.7 b), 5.6.8, 5.8.7, 5.8.8, 6.3.1, 6.5.1, 6.7.2, 6.9.6 d), 6.9.11, 6.10.5, 6.13.1, 6.16.3, 6.20.5, 6.20.10, 6.20.15 a), 6.21.6 b), 6.22.3 a), 7.2.2, 7.3.12, 7.7.6, 7.9.3, 7.9.10, 8.1.1 e), Tables 4.1 Note 5, 6.2
	residential	D3.1
	with smoke detectors (Type 7)	3.12.2 b), 4.5.10, 4.5.11, 6.22.2 g), A2.1
	fire systems centre (Type 20)	8.2.3, 8.2.4, A2.1
	heat detectors (Type 3)	3.5.3, 3.5.5, 4.5.4, 4.5.10, 4.5.11, 6.10.4 c), 6.11.3 b), A2.1
	manual (Type 2)	4.5.3, 4.5.9, 4.5.10 b), A2.1
	mechanical smoke extract (Type 11)	3.4.6 a), 3.4.8 d), 6.21.5, 6.22.7 c), 6.22.8 c), 6.22.11, 6.22.12, 6.22.14, A2.1, B3.1.1, Table 6.6
	modified smoke/heat detection (Type 5)	3.5.4, A2.1
	natural smoke venting (Type 10)	3.4.6 a), 3.4.8 d), 6.21.5, 6.22.7 b), 6.22.8 b) c), 6.22.10, 6.22.14, A2.1, B3.1.1, Table 6.5
	pressurisation of safe paths (Type 13)	3.7.1 b), 3.11.6 b), 6.9.6, 6.9.11, 6.13.1, 6.19.4 c), 6.21.2, 6.23.1 b), A2.1, B1.1.1, Table 6.1 Note 2
	refuge areas (Type 19)	3.13, A2.1, Figure 3.17
	smoke control in air-handling systems (Type 9)	6.23.2, A2.1
	smoke detectors (Type 4)	3.5.4, 3.5.5, 3.12.2 b), 3.17.10, 4.5.4, 4.5.10, 4.5.11, 6.22.2 g), 6.22.14, 6.23.1, A2.1, B1.1.1
	voice communication system (Type 8)	3.16.3 d), 8.2.6, A2.1

Amend 4
Oct 2005

Fire separations 1.3.5 b), 3.11.9, 4.1.1 a), 5.1.1, 5.3.1,
5.3.2 d) e), 5.6.3, 5.6.4, 5.6.5 c), 5.6.7, 5.7.2, 5.7.4,
6.2.1, 6.3.1, 6.6, 6.7, 6.8.1, 6.9.2, 6.9.3, 6.10.1, 6.10.2,
6.10.5, 6.11.1, 6.11.2, 6.12, 6.14.1, 6.14.4,
6.15.1 a), 6.16.2, 6.17, 6.18.4, 6.18.7 to 6.18.10,
7.2.1, 7.2.2, Table 6.1
junctions 6.12.4 to 6.12.7, 6.12.9, 6.18.4, Figure 6.4
protected shafts 6.16, Figure 6.8

Fire Service 4.2.6 c), 5.9.3 f), 6.21.2, 6.22.12 b), Part 8,
A2.1.1 Type 15 and Type 20
means of communication with A1.3.1, A2.1.1 Type 2 and Type 7
vehicular access 8.1.1, 8.1.2

Fire shutters see Fire resisting closures

Fire spread

horizontal 4.1.1 b), 7.1.1 b), 7.3, 7.8
vertical 4.1.1 b), 7.1.1 a), 7.9
between different levels of the same building . . . 7.9.10 to 7.9.15
external thermal insulation 7.9.18, 7.9.19, Figure 7.12
from an adjacent lower roof 7.9.6 to 7.9.9, Figure 7.11
roof car parking and storage 7.8.2, 7.9.16, 7.9.17

Amend 7
Nov 2008

Fire stopping 6.12.5, 6.12.7 a), 6.12.9, 6.17, 6.18.1,
6.18.4, C6.1.1, C6.1.2, Figures 6.4, 6.9, 6.11
cavity barriers 6.18.4, 6.18.6, Figure 6.12
curtain walls 7.9.14, Figure 6.11
external thermal insulation 7.9.18, Figure 7.12
hollow construction 6.17.5, Figure 6.12
protected shafts 3.12.3 e), 6.16.4, 6.16.5 e), Figure 6.8
service outlets 6.17.6, Figure 6.9

Firecell rating (F) see Fire resistance ratings

Firecells

Amend 4
Oct 2005

basements 3.7, 4.5.15, 6.14.4
buildings remaining occupied during fire 5.6.9, 5.6.10
car parking 6.10.3 to 6.10.6
ceiling space firecells 6.12.8

Amend 4
Oct 2005

concealed spaces 6.18.2, 6.18.3
concessions for multiple purpose groups 5.6.7, 5.6.8
construction 6.12

Amend 4
Oct 2005

firecells rated F0 6.2
fire hazard category 4 2.2.10, 5.6.11 to 5.6.13
fire safety precautions see Fire safety precautions
floor area limits 4.2.3 to 4.2.5

group sleeping areas 6.6.3, 6.6.4, 6.6.7, 6.7.2 to 6.7.5
intermediate floors 4.5.16 to 4.5.18, 6.14.1 a), 6.14.3,
6.21.3 to 6.21.6, Figure 6.6, Tables 6.5, 6.6
limited area atriums 6.22, Figure 6.14, Tables 6.4 to 6.6
plant, boiler and incinerator rooms 6.11.3, 6.11.4
protected shafts 6.16
provision of firecells 4.2
roofs 7.8.1 to 7.8.5, 7.9.1 to 7.9.9
solid waste storage 6.10.2
suites 2.2.9, 3.15.5, 6.6.5, 6.7.6, 6.9.6, 6.14.3, A2.1.1 Type 5
top floor firecells 4.5.14

Fireplace 9.5, Figures 9.1 and 9.3,
Table 9.1

Amend 3
Feb 2004

Flame barriers 3.14.6 b) c), 6.18.5 c), 6.20.12 a),
6.20.13, 6.20.14 b), C9.1, Table 6.3

Amend 7
Nov 2008

Flammability index (FI) C3.1, Table 6.2

FLED see Fire load energy density

Floors

basement floors 3.3.2 i), 3.15.2, 6.14.4, Figure 3.19
concealed spaces 6.18.4, 6.18.5 a), 6.18.10
fire resistance ratings 3.14.6 c), 3.15.3 c), 4.1.1 a),
4.3.2, 4.5.7, 5.3.1, 5.6.4 d), 5.6.7, 5.7.3,
6.10.3, 6.12.2, 6.14.2 to 6.14.4, 6.15.1
floor projections 7.8.6, 7.9.13
flooring materials 6.20.8, 6.20.14
intermediate floors 3.3.2 f), 3.4.6, 3.9.13, 4.5.16 to 4.5.18,
5.6.4 d), 5.6.5 b), 6.10.3, 6.14.1 a), 6.14.3,
6.21, 6.22, A2.1.1 Type 10 and Type 11, B4.1.1,
Figures 3.9, 6.6, Tables 6.4 to 6.6
limited area intermediate floors 4.5.17, 6.21.4 a), 6.21.5, 6.21.6
lower floors 3.16.9, 4.5.10, 4.5.11, 6.7.7, 6.9.3, Figure 3.5
more than one purpose group on a floor 4.5.1 to 4.5.6,
5.6.11, 5.6.12
other floors in a building 4.5.8 to 4.5.11
same purpose group on different floors 4.5.13
sloping floors and ceilings 3.4.8 a)
sub-floor spaces 6.15.1, 6.18.5 a), Figure 6.7
top floor firecells 4.5.14
upper floors 3.15.3 b), 3.16.3 a), 4.5.11, 5.6.13, 5.7.6 b),
6.7.7, 6.8.2, 6.8.6, 7.5.7, Figure 3.5
wooden floors 6.12.6, 6.20.14

Amend 4
Oct 2005

Amend 4
Oct 2005

Amend 4
Oct 2005

Amend 4
Oct 2005

Flues

gas burning appliances 9.2
oil fired appliances 9.3
solid fuel appliances 9.1

Amend 3
Feb 2004

Foamed plastics building materials 6.20.1, 6.20.5,
6.20.11 to 6.20.13, 7.9.18, Figure 7.12, Table 6.3

FRR see Fire resistance ratings

FSP see Fire safety precautions

Gas burning appliances
 installation 9.2
 seismic restraint 9.2.2

Glazing 5.8, 6.19.11
 concession for sprinklers 5.8.7, 5.8.8
 dimensions 5.8.3 to 5.8.5
 fire resisting glazing 5.8.1, 5.8.2, 7.3.3 c), 7.3.5, 7.3.7, 7.4,
 Figure 7.4, Table 7.1
 in external walls 5.8.2 a)
 in fire doors 5.8.10
 in fire separations 5.8.1, 5.8.2
 in safe paths 5.8.1 c), 5.8.3 to 5.8.8, Figure 5.1
 in smoke control doors 5.8.10, 5.8.11
 in smoke separations and protected paths 5.8.9

Group sleeping areas 6.6.3, 6.6.4, 6.6.7, 6.7.2 to 6.7.4

Handrails 3.1.4, 3.3.3, 3.3.6 b), 3.9.8, 6.20.4 c)

Hearths 9.5, Figure 9.3

Heat transfer solid fuel appliances
 limiting heat transfer **C/VM1** 1.1

Height see Building height or Escape height

Household units 1.3.5, 1.3.6 b) c) e), 2.2.9 a), 3.11.6,
 3.15.5, 3.15.8, 3.20.1, 6.1.1, 6.8.1, 6.14.3, 6.14.4,
 6.20.1, 7.5.7, 7.9.19, 7.10.7, 7.10.8, A2.1.1 Type 5, Table 6.2

Insulation see Fire resistance ratings

Integrity see Fire resistance ratings

Intermediate floors see Floors

Ladders see Stairs and ladders

Lifts 3.12.3, 6.16.1, 6.16.5 b) c), 6.23.3 b)
 doors 6.19.13, Table 6.1
 Fire Service lift control 8.2.5, A2.1.1 Type 15
 lift motor room 3.12.3 e), 6.16.5 c)

Amend 3
Feb 2004

Amend 3
Feb 2004

lift shafts see Protected shafts

Limited area atriums 6.22, Figure 6.14, Tables 6.4 to 6.6

Limited area intermediate floors see Floors

Liquid fuel appliances 9.7

Notional boundary 7.3.13 to 7.3.15, 7.5.3 Step 1, 7.7.1, Table 7.4

Occupants 1.3.2 Step 4, 3.1.1, 3.4.3, 3.8.4 a), 3.9.12 b),
3.17.3, 3.18.7, 4.2.6 a), 6.8.4

 children 3.15.1 e)

 occupant densities 2.3.3, 3.4.5 b), Table 2.2

 occupant loads –

 specific requirements and limitations 2.3, 3.3.2 d) e) f) g) i),
3.4.5, 3.4.8 c), 3.6.1 a) d), 3.9.11, 3.9.12 b) e),
3.10.1, 3.10.2, 3.12.2 b), 3.15.1 d), 3.16.3 c),
3.17.9 a), 4.4.1 Step 1 and Step 2, 4.5.15, 6.3.1,
6.3.2, 6.4.1, 6.20.6 a), 6.20.7 a), 6.20.19,
6.21.5 c), 6.22.2 c) d) f), B4.1.1, Tables 3.1, 4.1

Occupied spaces 3.2.1, 3.3.2 d), 6.6.7, 6.7.4, 6.22.3, Tables 2.1, 6.2

Oil fired appliances

 installation 9.3

 seismic restraint 9.3.2

Open fires 9.5, Figures 9.1 and 9.3

Open paths see Escape routes

Other property 4.3.2, 5.3.3 d), 6.1.1, 7.1.1 b), 7.3.1 b),
7.3.15 a), 7.7.1, 7.8.10 a), 7.9.1, 7.9.6 b), 7.9.10 d),
Tables 6.1, 7.3

Parapets 6.12.7 b), 7.1.2 e), 7.8.1 b),
7.8.2, 7.9.2 b), Figure 7.1

Penetrations 3.12.3 e), 6.12.4, 6.12.9 d), 6.16.5 e), 6.17.1, 6.17.4,
6.17.5, 6.17.7, 6.18.6 c), 6.18.9, 6.20.13 a)

People with disabilities 2.4, 3.15.1 e), 3.17.1 e)

Pressurisation of safe paths see Fire safety precautions

Protected paths see Escape routes

Protected shafts 6.10.4 a), 6.12.4, 6.16, Figure 6.8

Amend 3
Feb 2004

Amend 4 Oct 2005	Purpose groups 1.3.2 Step 3, 2.1.3, 2.2.1, 2.3.2, 3.4.2 b), 4.2.7 a) c), 4.5.1, 4.5.2, 4.5.8, 4.5.13, 5.6.7, 5.6.8, 5.8.4, 7.3.15 c), 7.5.10, 7.8.5, 7.9.6, 7.9.8 b), 7.11.3, Tables 2.1, 3.1 to 3.3, 4.1, 6.1 to 6.3, 7.5
Amend 4 Oct 2005	active purpose groups. 3.15.1 b), 3.15.3, 4.4.1 Step 2, Table 4.1 concessions for multiple purpose groups. 5.6.7, 5.6.8, 5.6.11, 5.6.12
Amend 4 Oct 2005	fire hazard category 4 2.2.10, 5.6.11, 5.6.12 primary purpose group 2.2.2, 2.2.4, 2.2.7, 4.2.7 c), 4.4.1 Step 1, 4.5.5, 6.10.1, 6.11.1, 6.11.2 residential community care 2.4 sleeping purpose groups. 3.9.12 f), 3.15.1 c), 3.15.5, 4.4.1 Step 2, 4.5.11, 5.3.3 a), 5.7.9, 6.1.2 b), 7.7.1, 7.8.10 a), 7.9.1, 7.9.16, 7.10.5 c), A1.2.1 Type 16, Tables 4.1, 7.4
	CL 2.2.3, 2.2.6, 3.5.2 a), 3.5.3 a), 3.5.4 a), 3.5.6 c), 3.16.1, 3.16.3, 3.16.7, 3.17.1 c), 3.17.9 a), 6.3, 6.20.7, 6.20.17, 6.20.18 d), 6.20.20, 6.22.1, A2.1.1 Type 16, Tables 2.1, 3.1 to 3.3, 6.2, 6.3
	CM 3.5.2 a), 3.5.3 a), 3.5.4 a), 3.5.6 c), 3.15.1 b), 3.15.3, 3.15.4, 3.17.1 c), 6.4, 6.20.17, 6.20.20, 6.22.1, 7.9.10 b), Figure 3.20, Tables 2.1, 3.1 to 3.3, 6.2, 6.3
	CO 3.9.3 b), 3.15.1 b), 3.16.5 to 3.16.7, 4.3.3, 6.5, A2.1.1 Type 16, Tables 2.1, 3.1, 3.3, 6.2, 6.3
	CS 2.2.3, 2.2.6, 2.2.7, 3.5.2 a), 3.5.3 a), 3.5.4 a), 3.5.6 c), 3.15.1 b), 3.15.3, 3.15.4, 3.18.1, 6.3.1, 6.20.7, 6.20.17, 6.20.20, 6.22.1, A2.1.1 Type 16, Figure 3.20, Tables 2.1, 3.1 to 3.3, 6.2, 6.3
	IA 3.5.2 a), 3.5.3 a), 3.5.4 a), 3.5.6 b), 3.10.2, 3.15.1 b), 3.15.3, 3.15.4, 4.3.3, 6.10, 6.22.1, A2.1.1 Type 16, Figure 3.20, Tables 2.1, 3.1 to 3.3, 6.3
	ID 3.5.2 a), 3.5.3 a), 3.5.4 a), 3.5.6 b), 3.15.1 b), 3.15.3, 4.3.3, 6.11, A2.1.1 Type 16, Tables 2.1, 3.1 to 3.3, 6.3
	IE 4.3.3, 6.9, 6.20.20, 7.3.1 a), 7.3.14, 7.5.3 Step 1, 7.9.6 a), 7.9.10 a), Tables 2.1, 6.2
Amend 4 Oct 2005	SA 2.2.3, 2.2.9, 2.3.6, 2.4.1, 3.5.2 b), 3.5.3 b), 3.5.4 b), 3.9.12 f), 3.9.14, 3.11.6, 3.15.1 c), 3.15.5 to 3.15.7, 3.16.9, 3.17.9 b) d), 3.18.1, 4.5.11, 5.7.6 b), 5.8.2 c), 6.7, 6.9.6, 6.14.3, 6.16.5, 6.18.7, 6.20.20, 6.22.1, 7.1.1 b), 7.3.1 a), 7.3.14, 7.5.3 Step 1, 7.5.7, 7.5.9, 7.5.10, 7.9.6 a), 7.9.10 a), A2.1.1 Type 4 Type 5 Type 7, Figures 3.21, 7.7, Tables 2.1, 3.1 to 3.3, 6.1 to 6.3, 7.5

	SC	2.3.6, 2.4.1, 3.9.12 f), 3.9.14, 3.11.6, 3.16.8, 3.17.4, 3.17.9 b) d), 4.5.11, 5.7.6 b), 5.8.2 c), 6.6, 6.9.6, 6.11.3, 6.20.8 b), 6.20.20, 7.1.1 b), 7.3.1 a), 7.3.14, 7.5.3 Step 1, 7.9.6 a), 7.9.10 a), 7.11.1, 8.1.2, Tables 2.1, 3.1 to 3.3, 6.1 to 6.3, 7.5
	SD	2.3.6, 3.9.12 f), 3.9.14, 3.11.6, 3.16.8, 3.17.4, 3.17.9 b) d), 4.5.11, 5.7.6 b), 5.8.2 c), 6.6, 6.9.6, 6.11.3, 6.20.8 b), 6.20.20, 7.1.1 b), 7.3.1 a), 7.3.14, 7.5.3 Step 1, 7.9.6 a), 7.9.10 a), 7.11.1, 8.1.2, Tables 2.1, 3.1 to 3.3, 6.1 to 6.3, 7.5
	SH	1.3.3, 1.3.4, 2.2.8, 2.2.9 b), 2.4.1, 3.5.2 b) to 3.5.4 b), 3.15.1, 3.20.1, 4.3.3, 5.9.4 c), 6.8, 6.14.3, 6.14.4, 6.20.1, 7.1.1 b), 7.3.1 a), 7.3.14, 7.5.3 Step 1, 7.5.7, 7.5.9, 7.5.10, 7.8.5, 7.9.19, 7.10.7, Step 1 7.10.9, 7.11.4, Figure 7.7, Tables 2.1, 3.3, 6.2, 6.3
	SR	1.3.5, 2.2.9 a), 2.4.1, 3.5.2 b), 3.5.3 b), 3.5.4 b), 3.11.6, 3.15.1 c), 3.15.5 to 3.15.7, 3.16.9, 3.17.9 b) d), 3.18.1, 3.20.1, 4.5.11, 5.7.6 b), 5.8.2 c), 6.8, 6.9.6, 6.14.3, 6.14.4, 6.16.5, 6.18.7, 6.20.1, 6.20.20, 6.22.1, 7.1.1 b), 7.3.1 a), 7.3.14, 7.5.3 Step 1, 7.5.7, 7.5.9, 7.5.10, 7.8.5, 7.9.6 a), 7.9.10 c), 7.9.19, 7.10.6 to 7.10.8, A2.1.1 Type 4 Type 5 Type 7, Figures 3.21, 7.7, Tables 2.1, 3.1 to 3.3, 6.1 to 6.3, 7.5
Amend 4 Oct 2005		
Amend 4 Oct 2005		
	WF	3.5.2 a), 3.15.1 b), 5.8.4, Tables 2.1, 3.1 to 3.3, 6.2, 6.3
	WH	3.5.2 a), 3.5.3 a), 3.5.4 a), 3.5.6 c), 3.15.1 b), 5.8.4, Tables 2.1, 3.1 to 3.3, 6.2, 6.3
	WL	3.5.2 a), 3.5.3 a), 3.5.4 a), 3.5.6 c), 3.15.1 b), 3.15.3, 3.15.4, 3.18.1, 6.22.1, Figure 3.20, Tables 2.1, 3.1 to 3.3, 6.2, 6.3
	WM	3.5.2 a) to 3.5.4 a), 3.5.6 c), 3.15.1 b), 3.15.3, 3.15.4, 6.11.1, Figure 3.20, Tables 2.1, 3.1 to 3.3, 6.2, 6.3
	Ramps	3.1.4, 3.9.2, 3.14.7
	Refuge areas	see Fire safety precautions
Amend 4 Oct 2005	Relevant boundaries	2.2.8, 5.3.2 a), 5.4.1 g), 5.7.6 a), 5.9.4 c), 7.1.2 d), 7.3.1 b), 7.3.4 to 7.3.6, 7.3.9, 7.3.12 b), 7.3.15 a), 7.4.2, 7.5 to 7.8, 7.10.5, 7.10.6, 7.11.4, Figures 7.3, 7.7 to 7.9, Tables 7.1 to 7.5
Amend 4 Oct 2005		

Roofs3.14.3, 3.14.4, 3.14.6 a), 3.16.7, 5.1.1 b),
6.12.1, 6.12.7, 6.18.5 c), 6.20.5, 6.20.11, 7.2.1 b), 7.8.1,
7.9.3 to 7.9.9, Figures 7.1, 7.11
 Amend 3 Feb 2004 | car parking and storage..... 7.8.2, 7.9.16, 7.9.17
 eaves and projections.....2.2.8, 7.8.3 to 7.8.5
 exterior surface finishes 7.11.1
 fire spread..... 7.1.1 a), 7.9.1, 7.9.2
 fire venting4.2.4, 5.4.1 i), 5.5.3, 6.3.2 b), 7.8.10 a)
 Amend 3 Feb 2004 | open sided buildings..... 7.8.8, 7.8.9, 7.8.10 a) b), Figure 7.10
 roof spaces 6.12.8, 6.18.5 b) c), 6.18.7, 6.18.8, 6.18.10

S rating see Fire resistance ratings

Safe paths..... see Escape routes

Safe place3.1.1, 3.7.1, 3.16.4, 3.16.8, 6.1.1, 6.22.7,
A2.1.1 Type 13 and Type 16

SDIsee Smoke developed index

Seating2.3.5, 3.3.2 k), 3.3.6 c), 3.9.3, 3.9.4,
3.9.7 to 3.9.11, 3.16.5, 3.16.6, 6.5.1,
Figures 3.13 to 3.15, Tables 2.2, 3.4
 open air auditoriums (purpose group CO)..... 3.16.5, 3.16.6, 6.5.1

SFI see Spread of flame index

Signs3.3.6 a), 3.17.11 d), 3.20

Single escape routes see Escape routes

Smoke control 3.11.9, 6.19.1, 6.19.12, 6.19.13, Table 6.1
 car parking..... 6.10.4 b), 6.10.6
 doors..... see Doors
 in air handling systems.....see Fire safety precautions
 intermediate floors3.4.6 a), 3.9.13 d), 4.5.17,
4.5.18, 6.21.3, 6.21.4
 limited area atriums.....4.5.18, 6.21.4 b), 6.22.1, 6.22.7, 6.22.8,
Figure 6.14, Table 6.4
 long corridors 6.13.1, Figure 6.5
 mechanical smoke extractsee Fire safety precautions
 natural smoke venting.....see Fire safety precautions
 pressurisationsee Fire safety precautions
 smoke reservoirs..... 6.22.2 f), 6.22.5, 6.22.7 to 6.22.10,
A2.1.1 Type 10 and Type 11,
Figure 6.14, Table 6.4
 systems.....3.4.6 a), 3.4.8 d), 3.9.13 d), 4.5.17, 6.21.5, 6.23.3 a),
A2.1.1 Type 9 Type 10 Type 11 Type 17, B1.1.1,
B2.2.1 Step 2, B3.1.1
 ventilation3.14.7, 6.9.6 to 6.9.8, 6.10.6
 vertical safe paths..... 6.9.11, Figure 6.1

Amend 7
Nov 2008

Smokecells 3.4.6 b), 4.2.2, 6.1.2 a), 6.4.1, 6.9.1, 6.12.4

Smoke developed index (SDI) 6.18.2 d), 6.20.3, 6.20.5,
6.20.7 c) d), C4.1.1 d), Table 6.2

Smoke separations 3.8.3 b), 3.11.1, 3.17.12 b), 6.1.2 c),
6.3.1, 6.6.4 b), 6.6.6 b), 6.9.6 e), 6.9.11,
6.10.1, 6.12.3, 6.12.4, 6.12.9, 6.13.1, 6.19.1, Table 6.1
glazing 5.8.9
smoke seals 6.12.9, 6.19.2 b), 6.19.4

Solid fuel appliances
installation 9.1
seismic restraint 9.1.2

Amend 3
Feb 2004

Amend 4
Oct 2005

Solid waste
chutes 3.12.1, 6.16.6, 6.16.6
storage 3.12.1, 6.10.2

Spandrels 7.1.2 e), 7.9.12, 7.9.13, Figure 7.2

Amend 7
Nov 2008

Spread of flame index (SFI) 6.18.2 d), 6.20.3, 6.20.5,
6.20.7 c) d), C4.1.1 b), Table 6.2

Sprinklers see Fire safety precautions

Stability see Fire resistance ratings

Stairs and ladders 3.1.4, 3.4.1 a), 3.4.7, 3.9.14, 3.15.9,
Figures 3.6, 3.10, 3.21
curved and spiral stairs 3.3.5, 3.4.7 a) b)
external stairways 3.14.6 c), 3.14.7, 3.15.4, 3.15.7,
Figures 3.22, 3.23
stairways 3.3.3, 3.3.4, 3.3.6 b), 3.4.5, 3.11.8, 3.12.3,
3.15.6, 5.8.2 c), 6.9.3, 6.9.10, 7.5.7

Standard tests see Test methods

Structural fire endurance rating (S) see Fire resistance ratings

Structural stability see Fire resistance ratings

Suites see Firecells

Surface finishes 6.1.2 e), 6.20, Tables 6.2, 6.3
ceilings 6.20.3, 6.20.5, 6.20.6, 6.20.11, 6.20.15 a)
exceptions 6.20.4
exterior surfaces 7.1.2 c), 7.8.6, 7.11
flooring and floor coverings 6.20.8 to 6.20.10, 6.20.14, C2.1
wharehous 3.3.2 h), 3.4.2 e), Table 2.2

Suspended flexible fabrics 6.20.1, 6.20.16 to 6.20.19,
C3.1, Table 6.2

Test methods Appendix C

- fire properties of external wall cladding systems C8.1
- fire resistance C6.1
- fire resisting closures C7.1
- flame barriers C9.1
- flammability of floor coverings C2.1
- flammability of membrane structures C3.1
- flammability of suspended flexible fabrics C3.1
- non-combustibility of materials C5.1
- properties of lining materials C4.1

Amend 7
Nov 2008

Amend 7
Nov 2008

Amend 7
Nov 2008

Unprotected areas 3.14.3, 3.14.6, 5.1.1 b), 7.1.2 d), 7.3,
7.4.1 a), 7.4.2, 7.5.2 to 7.5.6, 7.5.8, 7.6.4, 7.7.1,
7.7.3, 7.7.5 Step 2 and Step 3, 7.8.9, 7.8.10 c),
7.9.10, 7.9.11, 7.9.13, Figures 7.3 to 7.5,
Tables 7.2 to 7.4

- fire resisting glazing (Type B) 5.8.2 a), 7.4.1 a),
7.4.2 to 7.4.4, Figure 7.4, Table 7.1
- small openings (Type A) 7.4.1 a), 7.4.2, 7.4.4, Figure 7.4

Amend 3
Feb 2004

Ventilation 6.9.6

- balconies, bridges and open stairways 3.14.7
- cross-ventilation for car parking 6.10.4, 6.10.6
- gas burning appliances 9.2.2
- natural smoke ventilation see Fire safety precautions
- oil fired appliances 9.3.2
- safe paths 6.9.6 to 6.9.10
- solid fuel appliances 9.1.2

Amend 3
Feb 2004

Amend 3
Feb 2004

Amend 3
Feb 2004

Amend 4
Oct 2005

Walls 5.3.1, 5.7.2, 6.10.6, 6.12.1, 6.12.6, 6.16.2, 6.18.5 c),
6.20.3, 6.20.4 d) f), 6.20.5, 6.20.6, 6.20.11, 6.20.15 a),
7.8.9, 7.9.5, 7.9.18, Table 6.2

- cavities and concealed spaces 6.18.4, Figures 6.11, 6.12
- curtain walls 6.18.4, 7.9.14, Figure 6.11
- theatre proscenium walls 6.3.1, 6.3.2 f), 6.19.9,
6.19.10, 6.19.11, Figure 6.13

Windows 3.1.4, 6.20.4 c)

- fire windows see Glazing
- used for escape 3.3.6 d), 3.18, 6.20.6 b), Figure 3.32