



MINISTRY OF BUSINESS,
INNOVATION & EMPLOYMENT
HĪKINA WHAKATUTUKI

Acceptable Solutions and Verification Methods

For New Zealand Building Code Clause
G13 Foul Water

Archived

Second Edition



Status of Verification Methods and Acceptable Solutions

Verification Methods and Acceptable Solutions are prepared by the Ministry of Business, Innovation and Employment in accordance with section 22 of the Building Act 2004. Verification Methods and Acceptable Solutions are for use in establishing compliance with the New Zealand Building Code.

A person who complies with a Verification Method or Acceptable Solution will be treated as having complied with the provisions of the Building Code to which the Verification Method or Acceptable Solution relates. However, using a Verification Method or Acceptable Solution is only one method of complying with the Building Code. There may be alternative ways to comply.

Users should make themselves familiar with the preface to the New Zealand Building Code Handbook, which describes the status of Verification Methods and Acceptable Solutions and explains alternative methods of achieving compliance.

Defined words (italicised in the text) and classified uses are explained in Clauses A1 and A2 of the Building Code and in the Definitions at the start of this document.

Enquiries about the content of this document should be directed to:



**MINISTRY OF BUSINESS,
INNOVATION & EMPLOYMENT**
HĪKINA WHAKATUTUKI

Ministry of Business, Innovation and Employment
PO Box 1473, Wellington.
Telephone 0800 242 243
Fax 04 494 0290
Email: info@dbh.govt.nz

Archived

**Verification Methods and Acceptable Solutions
are available from www.dbh.govt.nz**

New Zealand Government

© Ministry of Business, Innovation and Employment 2014

This document is protected by Crown copyright, unless indicated otherwise. The Ministry of Business, Innovation and Employment administers the copyright in this document. You may use and reproduce this document for your personal use or for the purposes of your business provided you reproduce the document accurately and not in an inappropriate or misleading context. You may not distribute this document to others or reproduce it for sale or profit.

The Ministry of Business, Innovation and Employment owns or has licences to use all images and trademarks in this document. You must not use or reproduce images and trademarks featured in this document for any purpose (except as part of an accurate reproduction of this document) unless you first obtain the written permission of the Ministry of Business, Innovation and Employment.

Document Status

The most recent version of this document (Amendment 5), as detailed in the Document History, is approved by the Chief Executive of the Ministry of Business, Innovation and Employment. It is effective from 14 February 2014 and supersedes all previous versions of this document.

The previous version of this document (Amendment 4) will cease to have effect on 14 August 2014.

People using this document should check for amendments on a regular basis. The Ministry of Business, Innovation and Employment may amend any part of any Verification Method or Acceptable Solution at any time. Up-to-date versions of Verification Methods and Acceptable Solutions are available from www.dbh.govt.nz

G13: Document History			
	Date	Alterations	
First published	July 1992		
Amendment 1	September 1993	pp. vii–viii, References p. xi, Definitions	p.25, Figure 3 p. 31, Figure 7
Reprinted incorporating Amendment 1		October 1994	
Amendment 2	1 December 1995	p. viii, References	
Amendment 3	28 February 1998	p. ii, Document History p. viii, References	p. 1, 1.0.1 p. 21, 1.0.1
Second edition published 1 July 2001	Effective from 1 October 2001	Document revised – second edition issued	
Amendment 1	Published March 2007 Effective from 23 June 2007	p. ii, Document History, Status p. iii, Contents pp. 7–8, References	p. 9–10, Definitions p. 52A, AS3 1.0, 1.0.1, 1.0.2 p. 55, Index
Erratum 1	Effective from 23 June 2007	pp. 5–6, Contents pp. 33–34, AS1 8.0, 8.1	pp. 50–51, AS2 7.0, 7.1
Amendment 2	Effective from 21 June 2007	p. 2, Document History, Status pp. 3, 4, 4A, Building Code Clause p. 6, Contents	p. 8, References p. 52A, VM4 p. 54, Index
Amendment 3	Published 30 June 2010 Effective from 30 September 2010	p. 2, Document History, Status pp. 7–8, References p. 11, G13/VM1 1.0.1 p. 13, G13/AS1 Table 1 p. 32, G13/AS1 6.1.1 p. 33, G13/AS1 6.2.2, 6.3.1, 6.3.2, 7.1.2, Table 7	p. 37, G13/AS2 Table 1 p. 42, G13/AS2 5.1.2 p. 50, G13/AS2 6.1.2 p. 51, G13/AS3 1.0.1 pp. 54–55, Index
Amendment 4	Effective from 10 October 2011 until 14 August 2014	p. 2, Document History, Status p. 8, References	p. 10, Definitions p. 37, G13/AS2 Table 1
Amendment 5	14 February 2014	p. 2A, Document History, Status pp. 7–8, References p. 9, Definitions p. 35, G13/VM2 1.0.1	p. 44, G13/AS2 5.6.1 p. 51, G13/SA2 1.03 p. 52A, 1.1.2
Note: Page numbers relate to the document at the time of Amendment and may not match page numbers in current document.			

Archived

New Zealand Building Code

Clause G13 Foul Water

The mandatory provisions for building work are contained in the New Zealand Building Code (NZBC), which comprises the First Schedule to the Building Regulations 1992. The relevant NZBC Clause for Foul Water is G13.

1992/150	Building Regulations 1992	75
FIRST SCHEDULE—continued		
Clause G13—FOUL WATER		
Provisions	Limits on application	
OBJECTIVE		
G13.1 The objective of this provision is to:		
<ul style="list-style-type: none"> (a) Safeguard people from illness due to infection or contamination resulting from personal hygiene activities; and (b) Safeguard people from loss of <i>amenity</i> due to the presence of unpleasant odours or the accumulation of offensive matter resulting from <i>foul water</i> disposal. 		
FUNCTIONAL REQUIREMENT		
G13.2 <i>Buildings</i> in which <i>sanitary fixtures and sanitary appliances</i> using water-borne waste disposal are installed must be provided with—		
<ul style="list-style-type: none"> (a) an <i>adequate</i> plumbing and draining system to carry <i>foul water</i> to appropriate outfalls; and (b) if no <i>sewer</i> is available, an <i>adequate</i> system for the storage, treatment, and disposal of <i>foul water</i>. 		
PERFORMANCE		
G13.3.1 The <i>plumbing system</i> shall be constructed to:		
<ul style="list-style-type: none"> (a) Convey <i>foul water</i> from <i>buildings</i> to a drainage system, (b) Avoid the likelihood of blockage and leakage, (c) Avoid the likelihood of foul air and gases entering <i>buildings</i>, and (d) provide reasonable access for maintenance and clearing blockages. 		
G13.3.2 The drainage system shall:		
<ul style="list-style-type: none"> (a) Convey <i>foul water</i> to an appropriate <i>outfall</i>, (b) Be constructed to avoid the likelihood of blockage, 		

Amend 1
Jun 2007

Archived

76

Building Regulations 1992

1992/150

FIRST SCHEDULE—continued**Clause G13—FOUL WATER****Provisions**

- (c) Be supported, jointed and protected in a way that will avoid the likelihood of penetration of roots or the entry of ground water,
- (d) Be provided with reasonable access for maintenance and clearance blockages,
- (e) Be ventilated to avoid the likelihood of foul air and gases accumulating in the drainage system and *sewer*, and
- (f) Be constructed to avoid the likelihood of damage from superimposed loads or normal ground movement.

G13.3.3 Where a *sewer* connection is available, the drainage system shall be connected to the *sewer*, and the connection shall be made in a manner that avoids damage to the *sewer* and is to the approval of the *network utility operator*.

G13.3.4 If no *sewer* or available facilities for the storage, treatment and disposal of *foul water* must be constructed—

- (a) with *adequate* capacity for the volume of *foul water* and the frequency of disposal; and
- (b) with *adequate* vehicle access for collection if required; and
- (c) to avoid the likelihood of contamination of any potable water supplies in compliance with Clause G12 “Water supplies”; and
- (d) to avoid the likelihood of contamination of soils, ground water, and waterways except as permitted under the Resource Management Act 1991; and

Limits on application

Archived

1992/150

Building Regulations 1992

77?

FIRST SCHEDULE—continued

Clause G13—FOUL WATER

Provisions

- (e) from materials that are imper-
vious both to the *foul water*
for which disposal is required,
and to water; and
- (f) to avoid the likelihood of
blockage and leakage; and
- (g) to avoid the likelihood of foul
air and gases accumulating
within or entering into *build-
ings*; and
- (h) to avoid the likelihood of
unauthorised access by
people; and
- (i) to permit easy cleaning and
maintenance; and
- (j) to avoid the likelihood of
damage from superimposed
loads or normal ground move-
ment; and
- (k) if those facilities are buried
underground, to resist hydro-
static uplift pressures.

Limits on application

Amend 1
Jun 2007

Archived

Archived

Contents

	Page		Page
References	7	6.0 Installation	32
Definitions	9	6.1 Jointing methods	32
Verification Method G13/VM1 Sanitary Plumbing	11	6.2 Pipe supports	33
1.0 Sanitary Plumbing	11	6.3 Thermal movement	33
Acceptable Solution G13/AS1 Sanitary Plumbing	13	6.4 Fire separation	33
1.0 Scope	13	7.0 Watertightness	33
2.0 Materials	13	7.1 Test methods	33
2.1 Pipes, traps and fittings	13		
3.0 Water Traps	13	Verification Method G13/VM2 Drainage	35
3.1 Water trap requirements	13	1.0 Drainage	35
3.2 Water trap dimensions	14	Acceptable Solution G13/AS2 Drainage	37
3.3 Water trap location	14	1.0 Scope	37
3.4 Floor outlets	15	2.0 Materials	37
4.0 Discharge Pipes	18	2.1 Fill materials	37
4.1 Layout	18	3.0 Design	37
4.2 Access for cleaning	18	3.1 Bands	37
4.3 Diameter	19	3.2 Junctions	37
4.4 Gradient	20	3.3 Gully traps	38
4.5 Fixture discharge pipes serving waste water fixtures	20	3.4 Grease traps	40
4.6 Fixture discharge pipes serving soil fixtures	20	3.5 Gradient of drains	40
4.7 Discharge stacks	24	3.6 Diameter of drains	42
5.0 Venting	25	4.0 Drain Ventilation	42
5.1 Venting required	25	4.1 Ventilation requirements	42
5.2 Vent pipes	25	4.2 Diameter of drain vent pipe	42
5.3 Diameter of vent pipes	25	5.0 Installation	42
5.4 Gradient of vent pipes	29	5.1 Jointing	42
5.5 Connection of vents to fixture discharge pipes	29	5.2 Construction	42
5.6 Discharge stack and relief vents	31	5.3 Construction methods	42
5.7 Termination of open vent pipes	31	5.4 Trench width	44
5.8 Air admittance valves	31		

Erratum 1
Jun 2007

Archived

	Page
5.5	Placing and compacting 44
5.6	Proximity of trench to building 44
5.7	Access points 44
5.8	Additional requirements for drains installed under buildings 49
5.9	Access to drains under buildings 49
5.10	Disused drains 50
6.0	Watertightness 50
Erratum 1 Jun 2007	6.1 Testing 50
	Acceptable Solution G13/AS3 Plumbing and Drainage 51
Amend 1 Jun 2007	1.0 Installation of uPVC pipe 51
	Verification Method G13/VM4 On-Site Disposal 52A
	1.0 General 52A
Amend 2 Jun 2007	1.1 Scope 52A
	Index 53

Archived

References

For the purposes of New Zealand Building Code (NZBC) compliance, the Standards and documents referenced in these Verification Methods and Acceptable Solutions (primary reference documents) must be the editions, along with their specific amendments, listed below. Where these primary reference documents refer to other Standards or documents (secondary reference documents), which in turn may also refer to other Standards or documents, and so on (lower-order reference documents), then the version in effect at the date of publication of these Verification Methods and Acceptable Solutions must be used.

Amend 4
Oct 2011Amend 5
Feb 2014Amend 5
Feb 2014

		Where quoted
Standards New Zealand		
Amend 3 Sep 2010	NZS 3501: 1976 Specification for copper tubes for water, gas, and sanitation <i>Amends: 1, 2, 3</i>	AS1 Table 1, AS2 Table 1
Amend 5 Feb 2014	NZS 3604: 2011 Timber framed buildings	AS2 5.6.1
Amend 5 Feb 2014	NZS 4229: 2013 Concrete masonry buildings not requiring specific engineering design	AS2 5.6.1
Amend 3 Sep 2010	NZS 4442: 1989 Welded steel pipes and fittings for water, sewage and medium pressure gas	AS2 Table 1
British Standards Institution		
Amend 3 Sep 2010	BS 437: 2008 Specification for cast iron drain pipes, fittings and their joints for socketed and socketless systems	AS2 Table 1
Amend 3 Sep 2010	BS EN 12056-2:2000 Gravity drainage systems inside buildings. Sanitary pipework, layout and calculation	VM1 1.0.1
Standards Australia		
Amend 3 Sep 2010	AS 1579: 2001 Arc welded steel pipes and fittings for water and waste water	AS2 Table 1
Amend 3 Sep 2010	AS 1589: 2001 Copper and copper alloy waste fittings	AS1 Table 1
Amend 3 Sep 2010	AS 1646: 2007 Elastomeric seals for waterworks purposes	AS2 Table 1
Amend 3 Sep 2010	AS 2887: 1993 Plastic waste fittings	AS1 Table 1
Amend 3 Sep 2010	AS 3571: 2009 Plastic piping systems – Glass reinforced thermoplastics (GRP) systems based on unsaturated polyester (UP) resin – pressure and non-pressure drainage and sewerage (ISO 10467: 2004 MOD)	AS2 Table 1
Amend 4 Oct 2011		

Archived

		Where quoted
Amend 3 Sep 2010	AS 4139: 2003 Fibre reinforced concrete pipes and fittings	AS2 Table 1
	Australian/New Zealand Standards	
Amends 3 and 4	AS/NZS 1260: 2009 PVC-U pipes and fittings for drain, waste and vent applications <i>Amend: 1</i>	AS1 Table 1, AS2 Table 1
Amend 5 Feb 2014		
Amends 2 and 5	AS/NZS 1547: 2012 On-site domestic wastewater management	VM4 1.1.2
	AS/NZS 2032: 2006 Installation of PVC pipe systems <i>Amend: 1</i>	AS1 6.1.1, 6.2.2, 6.3.1, 7.1.2 AS2 5.1.2, 6.1.2, 7.0.1, Table 1 AS3 1.0.1
Amend 3 Sep 2010		
Amend 4 Oct 2011	AS/NZS 2033: 2008 Installation of polyethylene pipe systems <i>Amend: 1, 2</i>	AS1 Table 1
	AS/NZS 2280: 2012 Ductile iron pipes and fittings	AS2 Table 1
Amend 5 Feb 2014		
Amend 4 Oct 2011	AS/NZS 2566.2: 2002 Buried flexible pipelines installation	AS2 Table 1
	AS/NZS 3500:- Plumbing and drainage Part 2: 2003 Sanitary plumbing and drainage <i>Amend: 1, 2, 3, 4</i>	AS1 7.1.3, 8.0.1, 8.0.2, 8.1, VM2 1.0.1 Comment, AS2 6.1.3, 7.0.2, 7.1 AS3 1.0.1
Amend 1 Jun 2007 Amend 5 Feb 2014		
	AS/NZS 3518:2004 Acrylonitrile butadiene styrene (ABS) compounds, pipes and fittings for pressure applications <i>Amend: 1</i>	AS2 Table 1
	AS/NZS 4058: 2007 Pre cast concrete pipes (pressure and non pressure)	AS2 Table 1
	AS/NZS 4130: 2009 Polyethylene (PE) pipe for pressure applications <i>Amend: 1</i>	AS2 Table 1
Amend 3 Sep 2010	AS/NZS 4401: High density polyethylene (PE-HD) pipes and fittings for soil and waste discharge (low and high temperature) systems inside buildings 2006	AS1 Table 1
Amend 3 Sep 2010	AS/NZS 4936: 2002 Air Admittance valves for use in sanitary plumbing and drainage systems.	AS1 Table 1
Amend 4 Oct 2011	AS/NZS 5065: 2005 Polyethylene and polypropylene pipe and fittings for drainage and sewerage applications <i>Amend: 1</i>	AS2 Table 1
	European Standards	
	EN 12380: 1999 Air admittance valves for drainage systems – Requirements and test methods	AS1 5.8.2, Table 1
	American Society of Sanitary Engineers	
	ASSE 1050: 1991 Performance requirements for air admittance valves 1for plumbing DWV systems stack type devices	AS1 5.8.2, Table
	ASSE 1051: 1992 Performance requirements for air admittance valves for plumbing drainage systems	AS1 5.8.2, Table 1

Archived

Amend 1
Jun 2007

Definitions

Amend 1
Jun 2007

This is an abbreviated list of definitions for the words or terms particularly relevant to these Verification Methods and Acceptable Solutions. The definitions for any other italicised words may be found in the New Zealand Building Code Handbook.

Amend 5
Feb 2014

Access chamber A chamber with working space at *drain* level through which the *drain* passes either as an open channel or as a pipe incorporating an *inspection point*.

Access point A place where access may be made to a *drain* or *discharge pipe* for inspection, cleaning or maintenance; and may include a *cleaning eye*, *inspection point*, *rodding point*, *inspection chamber* or *access chamber*.

Adequate *Adequate* to achieve the objectives of the *building code*.

Air admittance valve A valve that allows air to enter but not to escape in order to limit pressure fluctuations within the sanitary plumbing or drainage system.

Branch discharge pipe A *discharge pipe* that serves one or more *fixture discharge pipes* for any one floor.

Branch vent pipe A *vent pipe* that serves two or more *fixture vent pipes*.

Amend 1
Jun 2007

Building has the meaning ascribed to it by Sections 8 and 9 of the Building Act 2004.

Cleaning eye A small *diameter access point* usually formed as part of a fitting or trap.

Combined waste pipe A *discharge pipe* which serves two or more *waste pipes*.

Developed length The total length along the centre line of a pipe including fittings and bends.

Diameter (or bore) The nominal internal *diameter*.

Discharge pipe Any pipe that is intended to convey discharge from *sanitary fixtures* or *sanitary appliances*.

Discharge stack A *discharge pipe* that has one or more *discharge pipe* connections, and which is vented at one end via a *discharge stack vent*.

Discharge stack vent A *vent pipe* connected to the top of the *discharge stack*.

Discharge unit The unit of measure for the discharge (hydraulic load) in the *plumbing system*, and is based on the rate, duration and frequency of discharge from a *sanitary fixture* or *sanitary appliance*.

Drain A pipe normally laid below ground level including fittings and equipment and intended to convey *foul water* or *surface water* to an *outfall*.

Drain vent pipe Any pipe which is intended to permit the movement of air into and out of the *drain* and *sewer*.

Fixture An article intended to remain permanently attached to and form part of a *building*.

Fixture discharge pipe A *discharge pipe* that is used to convey waste from a single *sanitary fixture* or *sanitary appliance* to a *branch discharge pipe*, a *discharge stack*, or directly to a *drain*. It does not include any pipes forming part of a *sanitary appliance*.

Fixture vent pipe (trap vent) A *vent pipe* that is connected to a *fixture discharge pipe* or the *sanitary fixture* itself.

Floor waste An outlet located at the low point of a graded floor or in a level floor designed to receive accidental or intentional discharges.

Floor waste pipe A pipe that receives the discharge from a *floor waste* and that discharges outside the *building* or to the *foul water* drainage or *sanitary plumbing system*.

Foul water The discharge from any *sanitary fixture* or *sanitary appliance*.

Foul water drainage system *Drains*, joints and fittings normally laid underground and used specifically for the conveyance of water from the *plumbing system* to an *outfall*.

Grease trap A device designed to intercept grease in a *foul water* discharge.

Gully trap A fitting designed to prevent foul air escaping from the drainage system and used to receive the discharge from *waste pipes*.

Inspection chamber A chamber with working space at ground level through which the *drain* passes either as an open channel or as a pipe incorporating an *inspection point*.

Inspection point A removable cap at *drain* level through which access may be made for cleaning and inspecting the drainage system.

Network utility operator means a person who—

- a) undertakes or proposes to undertake the distribution or transmission by pipeline of natural or manufactured gas, petroleum, biofuel, or geothermal energy; or
- b) operates or proposes to operate a network for the purpose of—
 - i) telecommunication as defined in section 5 of the Telecommunications Act 2001; or
 - ii) radiocommunications as defined in section 2(1) of the Radiocommunications Act 1989; or
- c) is an electricity operator or electricity distributor as defined in section 2 of the Electricity Act 1992 for the purpose of line function services as defined in that section; or
- d) undertakes or proposes to undertake the distribution of water for supply (including irrigation); or
- e) undertakes or proposes to undertake a drainage or sewerage system.

Outfall That part of the disposal system receiving *surface water* or *foul water* from the drainage system. For *foul water*, the *outfall* may include a *sewer* or a septic tank. For *surface water*, the *outfall* may include a natural water course, kerb and channel, or soakage system.

Plumbing system Pipes, joints and fittings, laid above ground and used for the conveyance of *foul water* to the *foul water drain* and includes *vent pipes*.

Relief vent A *vent pipe* which is connected to a *discharge stack* below the lowest branch connection and which connects at its upper end to the *discharge stack vent* or terminates as an open vent.

Rodding point A removable cap at ground level through which access may be made for cleaning and inspecting the drainage system.

Sanitary appliance An appliance which is intended to be used for *sanitation* and which is not a *sanitary fixture*. Included are machines for washing dishes and clothes.

Sanitary fixture Any *fixture* which is intended to be used for *sanitation*.

Sanitation The term used to describe the activities of washing and/or excretion carried out in a manner or condition, such that the effect on health is minimised, with regard to dirt, contamination and infection.

Sewer A *drain* that is under the control of, or maintained by, a *network utility operator*.

Soil fixture A *sanitary fixture* constructed to receive solid and/or liquid excreted human waste. It includes *ben* and disposal units, slops sins, urinals, water closet pans, and water-flushed *sanitary towel disposal units*.

Surface water All naturally occurring water, other than sub-surface water, which results from rainfall on the site or water flowing onto the site, including that flowing from a **drain**, stream, river, lake or sea.

Vent pipe A pipe for the purpose of protecting *water seals* that at its upper end is either open to the atmosphere or fitted with an *air admittance valve* and that at its lower end is connected to a *discharge pipe*.

Waste pipe A *discharge pipe* that conveys the discharge from *waste water fixtures* to a *gully trap*.

Waste water fixture A *sanitary fixture* or *sanitary appliance* used to receive wastes, and which is not a *soil fixture*.

Water seal The depth of water that can be retained in a *water trap*.

Water trap A fitting designed to retain a depth of water that prevents foul air and gases escaping from the *plumbing system* or *foul water drainage system* and entering a *building*.

Verification Method G13/MM1 Sanitary Plumbing

1.0 Sanitary Plumbing

1.0.1 A design method for conveying *foul water* from *buildings*, and for avoiding the likelihood of foul air entering *buildings*, may be verified as satisfying the relevant Performances of NZBC G13 if the method complies with BS EN 12056.2.

Amend 3
Sep 2010

Archived

Archived

Acceptable Solution G13/AS1

Sanitary Plumbing

1.0 Scope

1.0.1 This Acceptable Solution applies to above-ground non-pressure (gravity flow) sanitary plumbing for *buildings* having 3 levels or less and includes all pipework for *foul water* within, or on the *building*, including any basements.

1.0.2 The solution does not include:

- a) Specialised types of *sanitary fixtures* or *sanitary appliances* used within *buildings* such as hospitals, laboratories and factories, or
- b) The conveyance of industrial liquid wastes, chemical or toxic wastes and other wastes which cannot be discharged to a *sewer* without pretreatment.

1.0.3 Protection of water seals

Water seals shall be protected from pressure fluctuations within the sanitary pipework so as to prevent foul air and gases from entering the *building*. The method described in this Acceptable Solution for protecting *water seals* is based on a fully vented *plumbing system* and generally requires each *fixture discharge pipe* to be vented.

COMMENT:

Individually venting each *fixture discharge pipe* provides the greatest flexibility in the arrangement and lengths of *discharge pipes*.

2.0 Materials

2.1 Pipes, traps and fittings

2.1.1 Materials for sanitary *plumbing systems* using gravity flow shall comply with Table 1.

3.0 Water Traps

3.1 Water trap requirements

3.1.1 Discharge points from *sanitary fixtures* and *sanitary appliances* shall have a *water trap* to prevent foul air from the *plumbing system* entering the *building*.

3.1.2 *Water traps* shall be:

- a) Removable,
- b) Able to be dismantled, or
- c) Fitted with a *cleaning eye*.

COMMENT:

Removable panels are not required for access to bath traps.

Table 1: Pipes, traps and fittings
Paragraph 2.1.1

Material	Standard
Pipes and fittings	
Air admittance valves	ASSE 1050 or ASSE 1051, EN 12380, AS/NZS 4936
Copper pipe	NZS 3501
Copper fittings	AS 1589
PVC pipe and fittings	AS/NZS 1260
Plastic fittings	AS 2887
PE pipe and fittings	AS/NZS 4401
Elastomeric rings	AS/NZS 4130 or AS 1646
Traps	
Plastic	AS 2887
Copper	AS 1589

Amend 3
Sep 2010

Amend 3
Sep 2010

3.2 Water trap dimensions

3.2.1 Under normal operating conditions, *fixture traps* shall retain a *water seal* depth of not less than 25 mm (see Figure 1).

COMMENT:

1. The nominal depth of *water seal* is 75 ± 10 mm for *waste water fixture traps*.
2. The nominal depth of *water seal* is 50 ± 5 mm for *soil fixture traps*.
3. The system should be tested under load conditions to ensure that a 25 mm minimum *water seal* depth is not compromised.

3.2.2 The *diameter* of the *water trap* shall be not less than that given in Table 2.

3.3 Water trap location

3.3.1 A *water trap* shall:

- a) Be located as close as possible to the *sanitary fixture* or *sanitary appliance* it serves,
- b) Have a *discharge pipe* with a *developed length* not exceeding 1.2 m measured between the *water seal* and either the *sanitary fixture* outlet or the *sanitary appliance* discharge point, and
- c) Not be located in a different room to the *sanitary fixture* or *sanitary appliance* it serves.

COMMENT:

1. Waste material may build up on the walls of *discharge pipes* and may cause offensive odours to enter the *building* through the *fixture* outlet. A short *discharge pipe* reduces the likelihood of this happening.
2. Trap may be located under the floor or in ceiling spaces of the floor below.

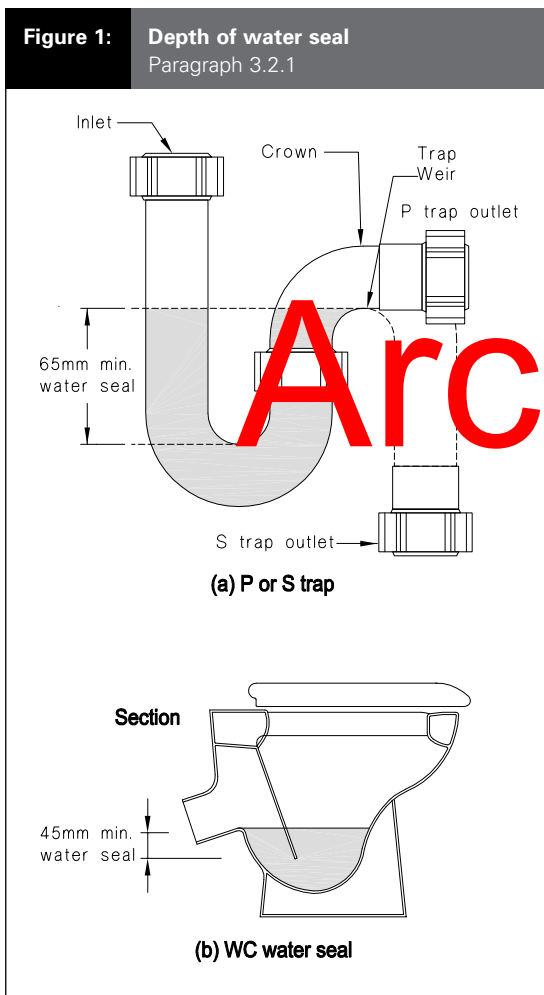

3.3.2 Multiple outlets

A single *water trap* may serve any one of the following outlet combinations located within the same space (see Figure 2):

- a) One or two adjacent domestic kitchen sinks together with a dishwashing machine.
- b) One or two adjacent domestic kitchen sinks together with a waste disposal unit.
- c) One or two adjacent laundry tubs together with a clothes washing machine.
- d) Two adjacent basins, domestic kitchen sinks or laundry tubs.
- e) One or two adjacent domestic kitchen sinks, together with a waste disposal unit and a dishwashing machine when fitted with a 50 mm trap and *discharge pipe*.

COMMENT:

Commercial sinks – one *water trap* is not permitted to serve two adjacent commercial sinks, as a sink containing *foul water* may contaminate an adjacent sink being used for food preparation.

Table 2: Fixture discharge pipe sizes and discharge units
Paragraphs 3.2.2, 4.3.1, 4.3.2 and 4.7.1

Sanitary fixture or appliance	Discharge units	Minimum trap and discharge pipe diameter (mm)
Basin	1	32
Bath (with or without overhead shower)	4	40
Bathroom group (water closet pan, bath and shower, basin, and bidet in one compartment)	6	(Note 1)
Bidet	1	32
Cleaner's sink	1	40
Clothes washing machine (domestic)	5	40
Dishwashing machine (domestic)	3	40
Drinking fountain	1	25
Kitchen sink (commercial)	3	50
Kitchen sink (domestic, single or double, with or without waste disposal unit)	3	40
Laundry (single or double tub, with or without a clothes washing machine)	5	40
Shower	2	40
Urinal (1 or 2 stall)	1 per 600 mm length	50
Urinal (bowl type)	1	32
Urinal (3 or more stalls)	1 per 600 mm length	80
Water closet pan	4	80
Note:		
1. For groups of fixtures, traps are sized for the individual fixtures. Discharge pipes for groups are sized in accordance with Paragraph 4.3.2.		

Archived

3.4 Floor outlets

3.4.1 Floor waste outlets shall have a removable grating that is flush with the floor.

COMMENT:

1. The grating is to permit safe and easy movement of people using the space containing the floor outlet.
2. Floor wastes in this section are not intended to receive liquid or excreted human wastes.

3.4.2 The floor waste, and the water trap if used, shall have a minimum diameter of 40 mm.

3.4.3 A floor waste shall:

- a) Be trapped, discharge 50 mm above the grating of a gully trap and be vented as shown in Figure 3,

- b) Be trapped, charged to maintain the water seal and discharge to the foul water plumbing system in accordance with Paragraphs 4.5 and 5.0, or
- c) If its only purpose is to discharge accidental overflows:
 - i) have no water trap,
 - ii) discharge to the open air within the property boundary,
 - iii) discharge to a safe location, and
 - iv) be fitted with a means to prevent the entry of birds and vermin.

Figure 2: Multiple outlets
Paragraph 3.3.2

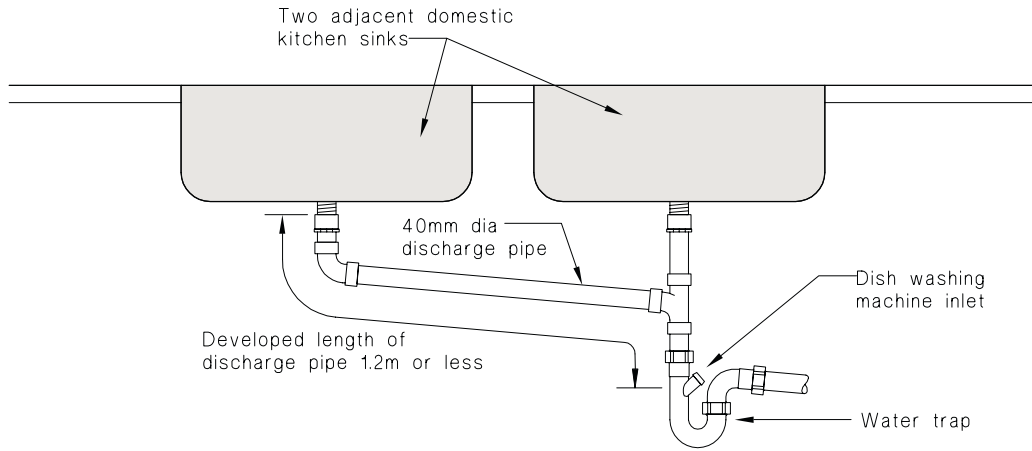

(a) Two adjacent domestic kitchen sinks and one dishwasher inlet

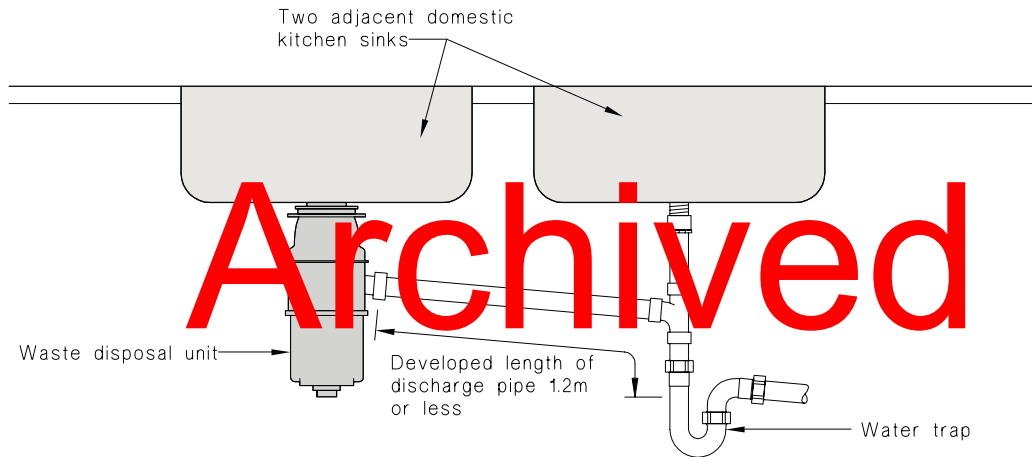

(b) Two adjacent domestic kitchen sinks and one disposal unit

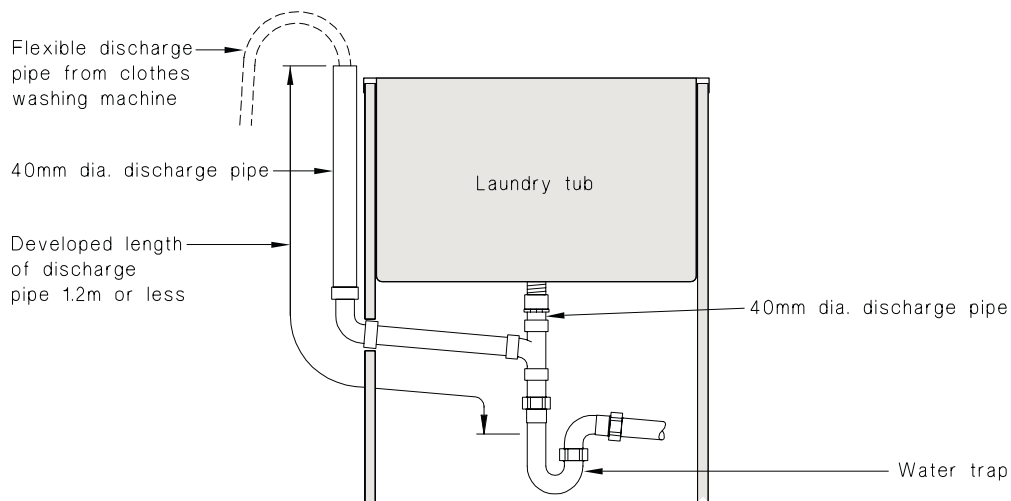

(c) Laundry tub and discharge pipe for a clothes washing machine

Figure 3: Floor waste stacks and pipes
Paragraphs 3.4.3 and 3.4.4

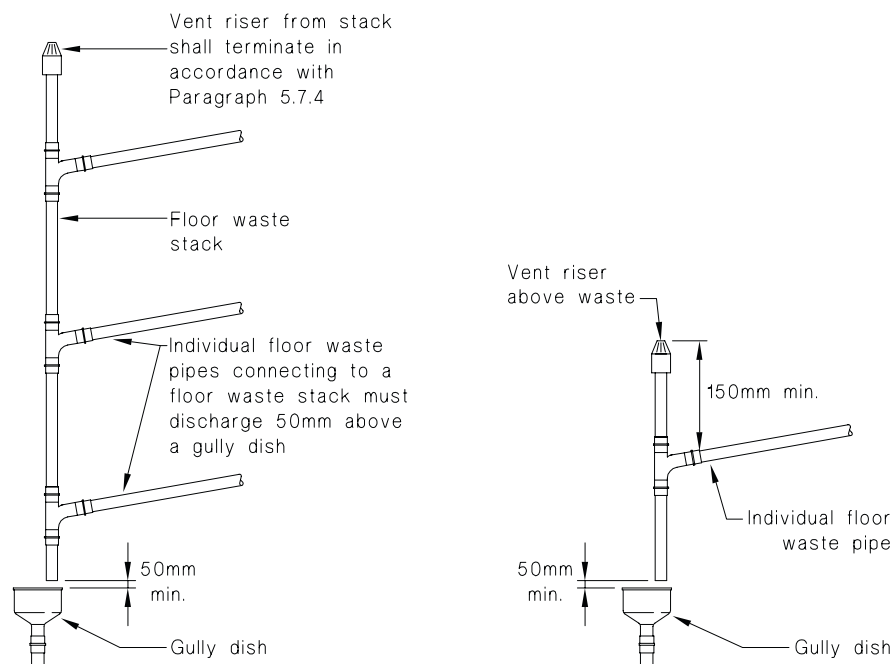

(a) Multiple floor waste pipes connecting to floor waste stack

(b) Single floor waste pipes connecting to floor waste stack

Archived

Table 3: Diameters for floor waste discharge pipes
Paragraph 3.4.4

Number of floor wastes	Diameter of waste outlet (mm)	Discharge stack size (mm)
1 – 3	40	40
4 – 6	40	50
1 – 3	50	50
4 – 6	50	80

3.4.4 *Floor waste pipes* may be combined to form a *floor waste stack* and shall have a *diameter* not less than that given in Table 3 (see Figure 3).

Individual *floor waste pipes* connected to a *floor waste stack* need not be vented (see Figure 3).

3.4.5 *Floor waste discharge stacks* shall:

- a) Be open vented,
- b) Be vented independently from any other sanitary plumbing system, and
- c) Comply with the termination requirements of Paragraph 5.7.4.

COMMENT:

Independent venting reduces the risk of foul air and gases entering the *floor waste* system.

3.4.6 Charging floor wastes

The *water seal* of a trapped *floor waste* discharging directly to the *foul water plumbing system* shall be maintained by (see Figure 4):

- a) A charge pipe of not less than 32 mm *diameter* from a tap or a *drain* from a hot or cold water relief valve, which shall drain over a tundish so that the air gap is maintained,
- b) A mechanical trap priming device and *discharge pipe*,
- c) A tap for floor washing, located in the same room and in close proximity to the *floor waste*.

In all cases the charge pipe shall have a maximum length of 10 m.

All trap charging systems shall incorporate backflow prevention in accordance with G12/AS1.

COMMENT:

Backflow protection can be achieved by an appropriate air gap or backflow prevention device.

4.0 Discharge Pipes

4.1 Layout

4.1.1 *Discharge pipes* shall follow the most practicable route with the least number of bends.

4.2 Access for cleaning

4.2.1 *Access points* shall be provided in *discharge pipes* to allow the easy clearance of blockages.

4.2.2 *Access points* shall be provided at the following points:

- a) At the junction of a soil *discharge pipe* with a *discharge stack*,
- b) Where a number of changes of direction occur,
- c) In a *discharge pipe* where access to junctions or changes of direction are restricted, and
- d) At the base of any soil stack at the point of connection to the *drain*.

COMMENT:

Proprietary fittings that provide access into the pipe should be used at these points.

Archived

Figure 4: Methods of charging floor waste traps
Paragraph 3.4.6

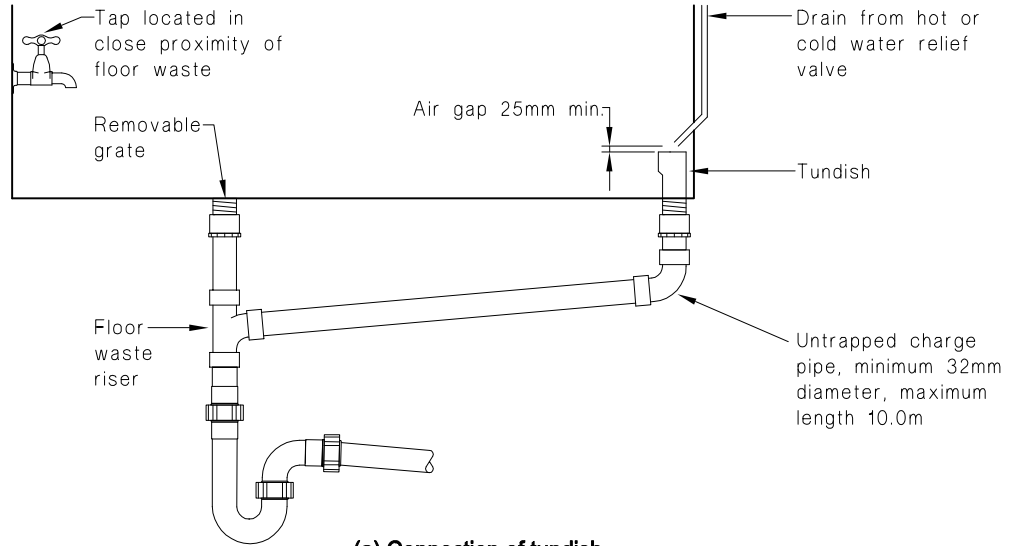

(a) Connection of tundish

Archived

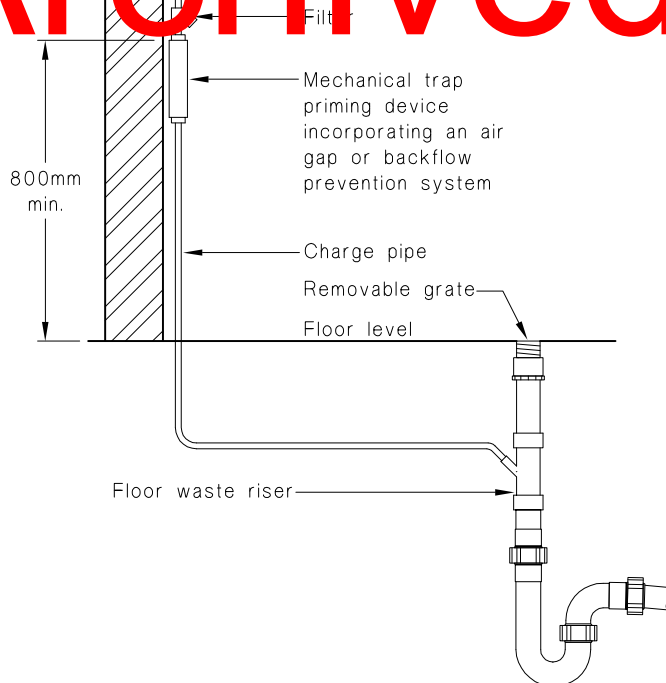

(b) Trap primer arrangement

4.3 Diameter

4.3.1 *Fixture discharge pipes* shall have *diameters* of not less than those given in Table 2 and shall not decrease in size in the direction of flow.

4.3.2 Where a *discharge pipe* receives the discharge from more than one *fixture*, the *diameter* of the *discharge pipe* shall be not less than that required in Table 4 using:

- a) The *discharge unit* loading to be conveyed, calculated as the sum of the *discharge unit* loading given in Table 2, for all *fixtures* served, and
- b) The gradient of the *discharge pipe*.

4.4 Gradient

4.4.1 The gradient of *discharge pipes* shall be not less than that required in Table 4 for the relevant *discharge unit* loading.

COMMENT:
The minimum gradients specified are necessary to avoid the risk of blockage.

Archived

4.5 Fixture discharge pipes serving waste water fixtures

4.5.1 *Waste water fixture discharge pipes* shall discharge either to:

- a) A *gully trap*, in accordance with Figure 5 of G13/AS1 and Figure 3 of G13/AS2, or
- b) A *discharge stack* as in Paragraph 4.7 and Figures 7 and 8.

4.5.2 *Water seal* protection: *Waste water fixture discharge pipes* shall be vented to comply with Paragraph 5.0 and as required in Table 5.

4.6 Fixture discharge pipes serving soil fixtures

4.6.1 *Fixture discharge pipes* serving *soil fixtures* shall discharge either:

- a) Directly to the *drain*, as shown in Figure 6(1), or
- b) To a stack, as in Paragraph 4.7 and as shown in Figures 7 and 8.

4.6.2 *Water seal* protection: *Soil fixture discharge pipes* shall be vented to comply with Paragraph 5.0 and as required in Table 5 (see Figure 6(2)).

Table 4: Discharge unit loading for stacks and graded discharge pipes
Paragraphs 4.3.2, 4.4.1 and 4.7.1

Diameter (mm)	Maximum discharge from any one floor	Vertical stack (Note 1)	Graded discharge pipes					
			Minimum gradient					
			1:20	1:30	1:40	1:50	1:60	
32	1	1	1					
40	2	6	6	5	4			
50	5	15	15	10	8			
65	6	18	51	29	21			
80	13	40	65	39	27	20	16	
100	65	195	376	248	182	142	115	

Note:
Shaded area = not permitted
1. Total loading at the base of the *discharge stack*.

Figure 5: Waste pipes discharging to a gully trap
Paragraph 4.5.1 a)

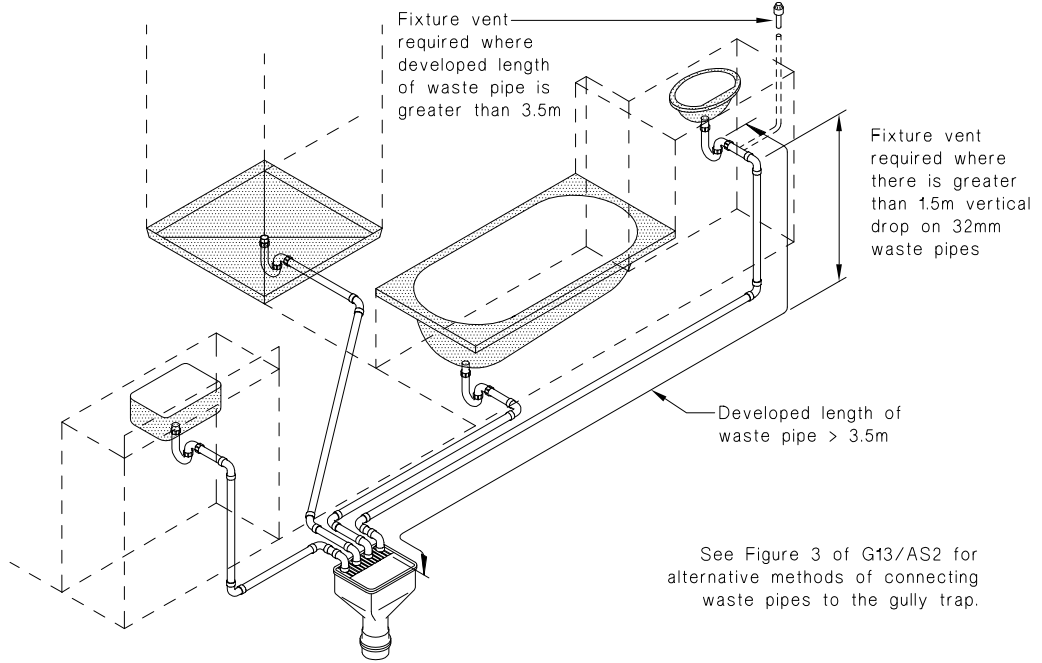

Archived

(a) Individual waste pipes
Each waste pipe must be vented in accordance with Paragraph 5.0

Connect fixture vent pipe within 3.5m of crown of water trap

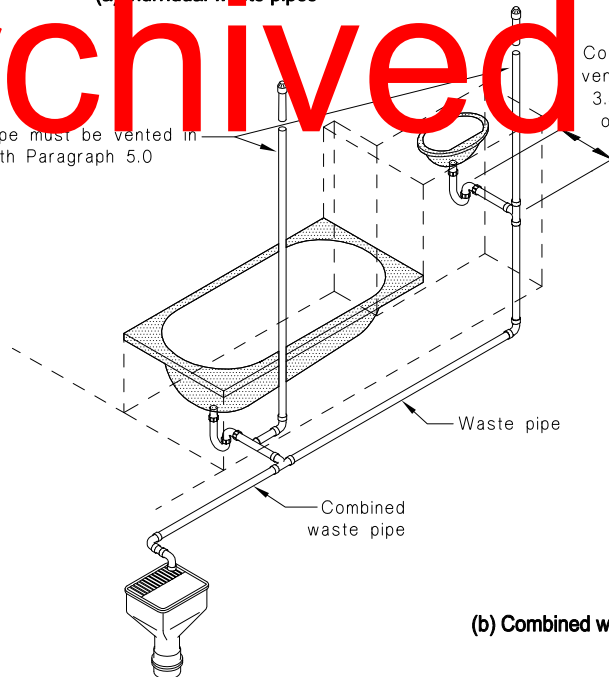

(b) Combined waste pipes

Note:

Upper floor waste pipes may discharge to a gully trap however venting will be required where wastes are combined or where specified lengths are exceeded. See Table 5.
Waste pipes may also discharge to a stack. See Figures 7 and 8.

Figure 6: Soil fixture discharge pipes
Paragraphs 4.6.1 a), 4.6.2, 5.5.2 a)

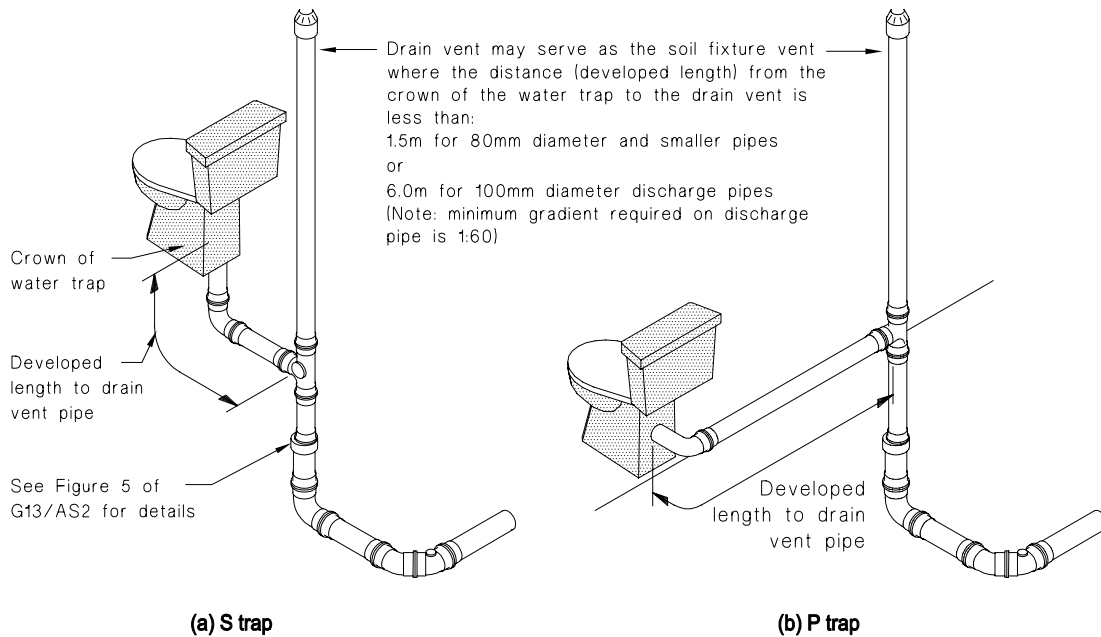

1) Discharge pipes serving soil fixtures connected individually to the drain and utilising a drain vent as fixture vent

- a) S or P trap vented pan, fixture vent pipe connected to girth horn installed and terminated in accordance with Paragraph 5.0
- b) S or P trap pan, fixture vent pipe connected to pan air admittance valve (to pan horn) to be installed in accordance with Paragraph 5.0 (valve must be vertical and secured in place)

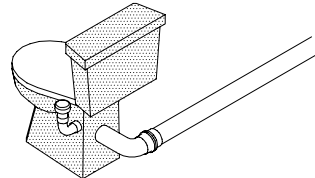
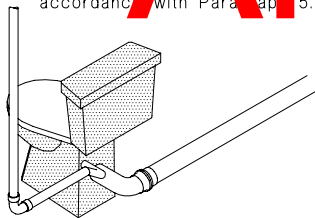

- c) S or P trap non vented pan, fixture vent pipe connected to the graded discharge pipe within 1.5m from the crown of the water trap and 300mm above any bend at the base of vertical drop
- d) S or P trap non vented pan, fixture vent connected to the vertical discharge pipe as for c)

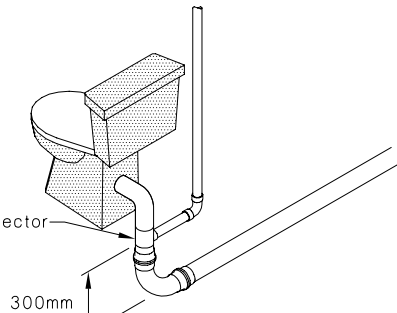
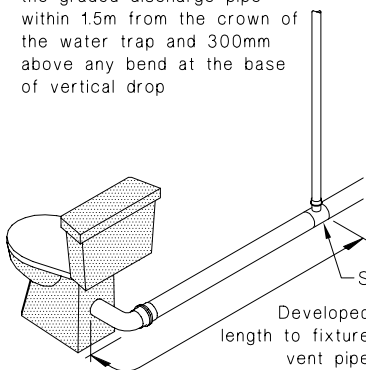

2) Discharge pipes serving soil fixtures connected individually to the drain or to a stack and utilising a fixture vent

Figure 7: Vertical discharge stack
Paragraphs 4.5.1 b), 4.6.1 b), 4.7.1 b), 4.7.2 a), 5.2.1 b), 5.6.2, 5.6.3 a) b)

Discharge stack vent may serve as the fixture vent pipe where discharge pipe is the top most branch connection (see Table 5)

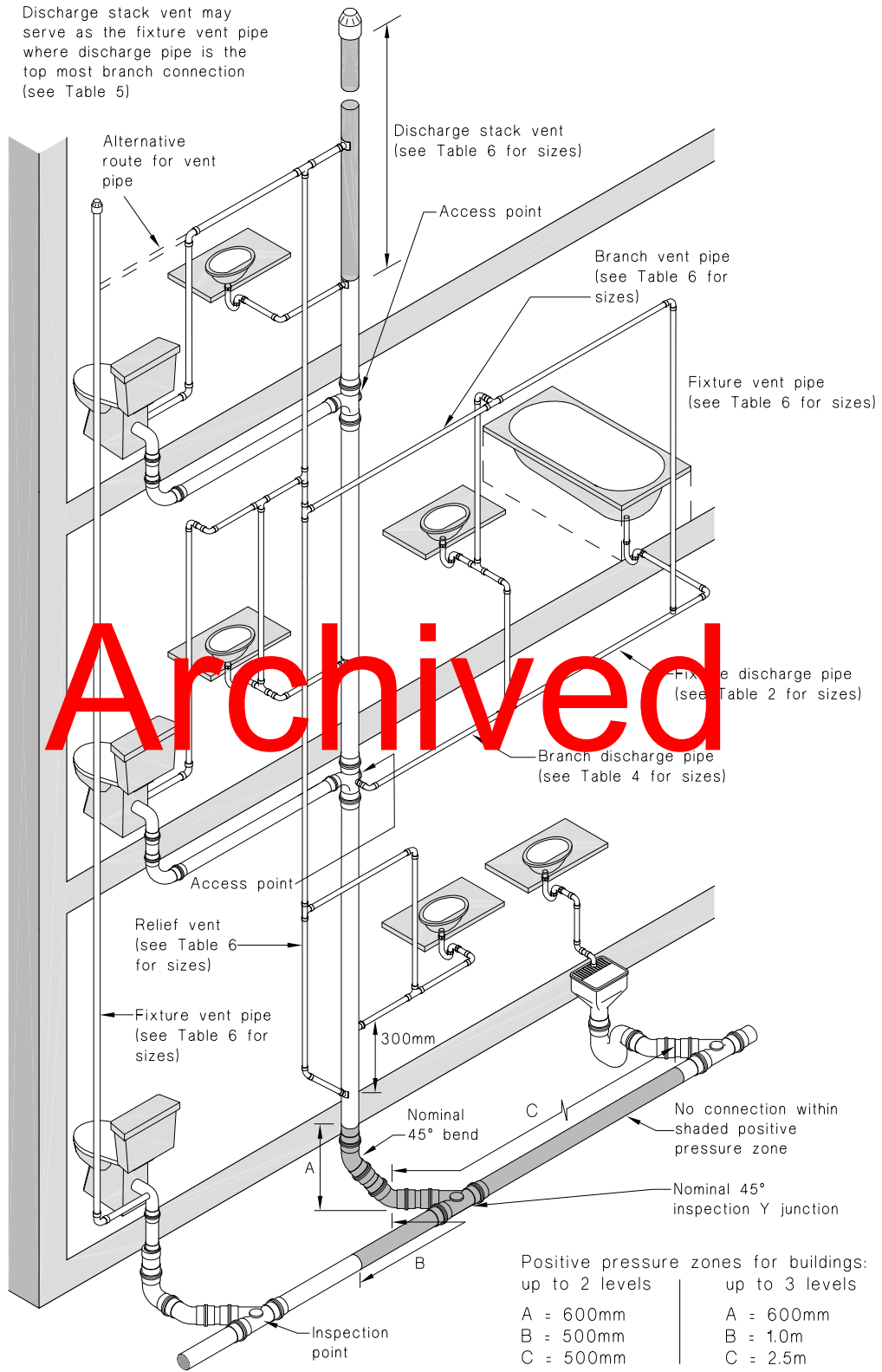
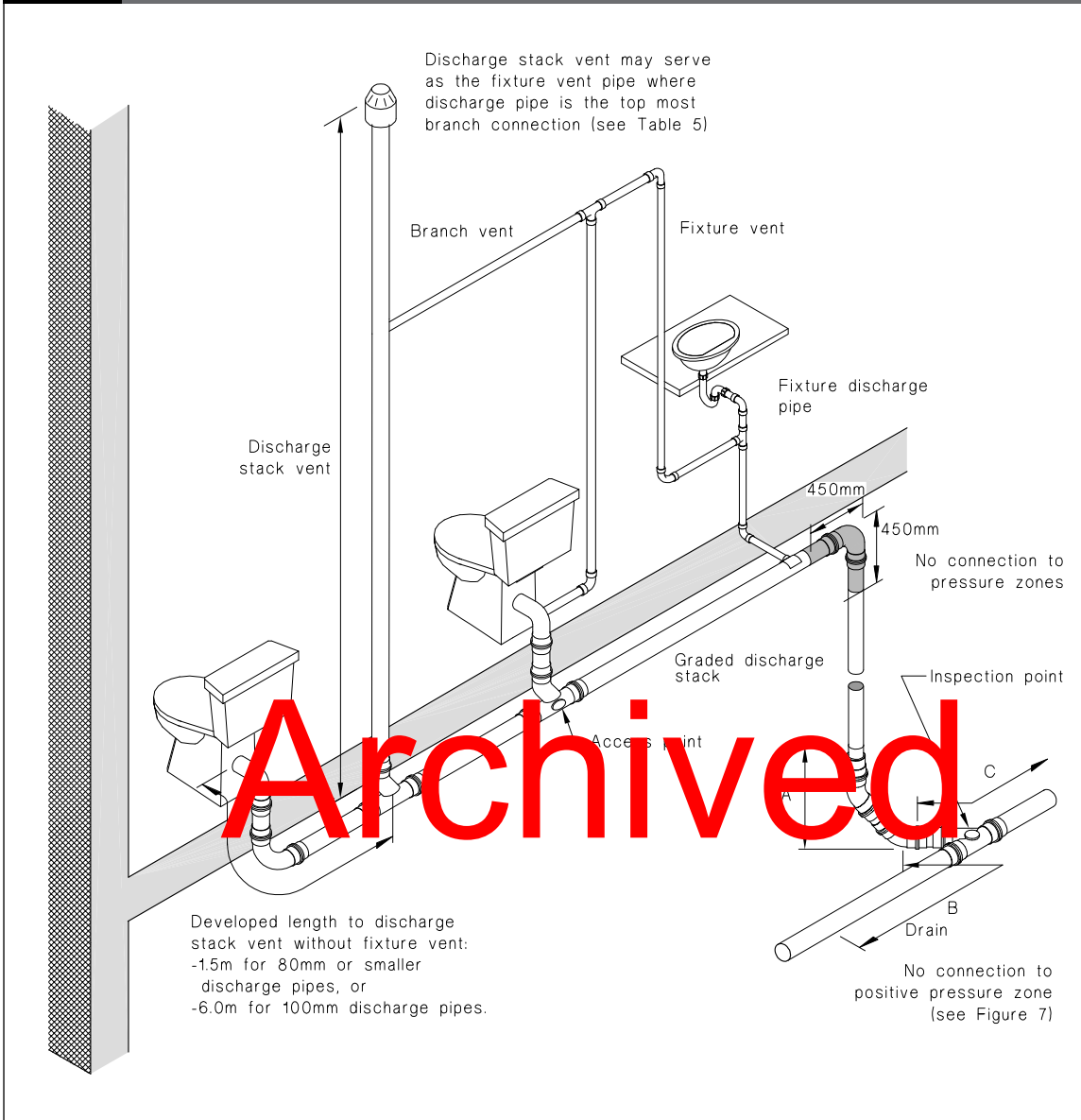

Figure 8: Graded discharge stack
Paragraphs 4.5.1 b), 4.6.1 b), 4.7.1 c), 4.7.3, 5.2.1 b)



4.7 Discharge stacks

4.7.1 Discharge stacks shall:

- a) Have a *diameter* of not less than that given in Table 4 using:
 - i) the *discharge unit* loading to be conveyed, calculated as the sum of the *discharge unit* loadings required in Table 2 for all *fixtures* served, and
 - ii) the gradient of the *discharge stack*.
- b) For vertical stacks, be extended up past the top-most branch connection to form a *discharge stack vent* (see Paragraph 5.0 and Figure 7).
- c) For graded *discharge stacks*, have a *discharge stack vent* connected to the graded section of the stack downstream of the highest *fixture*, in accordance with Paragraph 5.0 and Figure 8.

4.7.2 Where *discharge pipe* connections to vertical *discharge stacks*:

- a) Are near the base of a *discharge stack*, they shall not be connected to the *discharge stack* or *drain* within the positive pressure zone as shown in Figure 7.

COMMENT:

Whenever a *discharge stack* incorporates a bend greater than 45°, a hydraulic jump may occur in the horizontal pipe downstream of the bend. The hydraulic jump can cause very high positive pressures in the pipe near the bend. If a branch pipe is connected to the *discharge stack* in this zone, these high pressures may blow out *water seals* connected to that branch pipe.

- b) Consist of two branches entering the *discharge stack* at the same level, they shall have a double Y-junction with either:
- i) sweep entries, or
 - ii) entries with an included angle of 90° (see Figure 9 (b)).
- c) Are at different levels, they shall not be connected to the *discharge stack* within the restricted entry zones shown in Figure 9 (a), unless the connection method is in accordance with Figures 9 (b) and (c).

4.7.3 Where *discharge pipe* connections are to graded *discharge stacks* they shall not enter at opposite positions and if they are near bends they shall not be made within 450 mm of any bend (see Figure 8).

4.7.4 The change of direction at the base of any vertical section in a *discharge stack* shall incorporate:

- a) Two nominal 45° bends, or
- b) One nominal 45° bend and a Y-junction.

5.0 Venting

5.1 Venting required

5.1.1 *Discharge pipes* shall be vented where required by Table 5.

5.1.2 *Vent pipes* that serve *fixtures* that discharge to a *gully trap* or *grease trap* shall be vented independently of any *vent pipe* system connected directly to the *foul water drainage system*.

COMMENT:

An independent *vent pipe* system for *fixtures* discharging to a *gully trap* is necessary to avoid the risk of *sewer gases* escaping through any *waste pipes* discharging to a *gully trap*.

5.2 Vent pipes

5.2.1 *Vent pipes* shall be one of the following types:

- a) A vertical or graded *fixture vent pipe* terminating in accordance with Paragraph 5.7.1 or 5.8.1 (see Figure 10 (a)), or
- b) An ascending graded or vertical *fixture vent pipe* to connect to:
 - i) a branch *vent pipe*, as shown in Figure 10 (b),
 - ii) a *discharge stack vent* as shown in Figures 7, 8 and 10 (b), or
 - iii) a *header vent* as shown in Figure 7.

The connection shall be made at a height of not less than 50 mm above the overflow level of the *sanitary fixture* it serves.

5.3 Diameter of vent pipes

5.3.1 *Fixture vent pipes*, *branch vent pipes*, *discharge stack vents* and *relief vents* shall have a *diameter* of no less than that given in Table 6.

Table 5: Venting requirements
Paragraphs 4.5.2, 4.6.2, 5.1.1, 5.5.1, 5.5.2 and 5.8.1**Stacks**

Stack vent: All stacks discharging to another stack or to a *drain* require an open vent, sized in accordance with Table 6. Venting with an *air admittance valve* is permitted only on second and subsequent stacks as at least one open vent (the stack vent, if acting as main *drain* vent) is required to ventilate the *drain*.

Relief vent: All stacks that receive discharges from 3 floor levels shall be vented with a *relief vent* sized in accordance with Table 6. *Relief vents* shall be open vented.

Fixtures connected to a stack

All connections to a stack, except the highest connection, require venting by either an open vent, or an *air admittance valve*, sized in accordance with Table 6.

Highest fixture connected to a stack

The individual highest connection to a stack requires venting by either an open vent, or an *air admittance valve*, sized in accordance with Table 6, if the *discharge pipe* is longer than:

- 6 m for 100 mm pipe,
- 1.5 m for 80 mm pipe, and
- 3.5 m for 65 to 32 mm pipes.

Soil fixtures connected to an unvented branch drain

All *soil fixtures* connected to an unvented branch *drain* require venting by either an open vent, or an *air admittance valve*, sized in accordance with Table 6.

Soil fixtures connected to a vented drain with a gradient of less than 1:60

All *soil fixtures* connected to a vented *drain*, where the branch and the vented *drain* are at a gradient of less than 1:60, require venting by either an open vent, or an *air admittance valve* sized in accordance with Table 6.

Individual soil fixtures connected to a vented drain with a gradient of 1:60 or steeper

Individual *soil fixtures* connected to a vented *drain*, where the branch and the vented *drain* are at a gradient of 1:60 or steeper, require venting by either an open vent, or an *air admittance valve*, sized in accordance with Table 6, if the *discharge pipe* is longer than:

- 6 m for 100 mm pipe, or includes a vertical drop greater than 2 m, and
- 1.5 m for 80 mm pipe *diameters*.

Fixtures discharging to a gully trap

1. *Fixtures* connected to a combined *waste pipe* require venting by either an open vent, or an *air admittance valve*, sized in accordance with Table 6.
2. Individual *fixture discharge pipes* over 3.5 m in length require venting by either an open vent, or an *air admittance valve*, sized in accordance with Table 6.
3. Where any 32 mm *discharge pipe* has a vertical drop of greater than 1.5 m it shall be vented with a 32 mm vent pipe or an *air admittance valve*.

Venting of main drains

Main *drains* discharging to the *sewer* or to an on-site disposal system are required to be vented with a minimum 80 mm open vent.

Venting of branch drains

Branch *drains* connected to a vented *drain* that exceed 10 m in length require venting with an open vent, sized in accordance with Table 6.

Archived

Figure 9: Restricted zone connections to stacks
Paragraph 4.7.2 b) c)

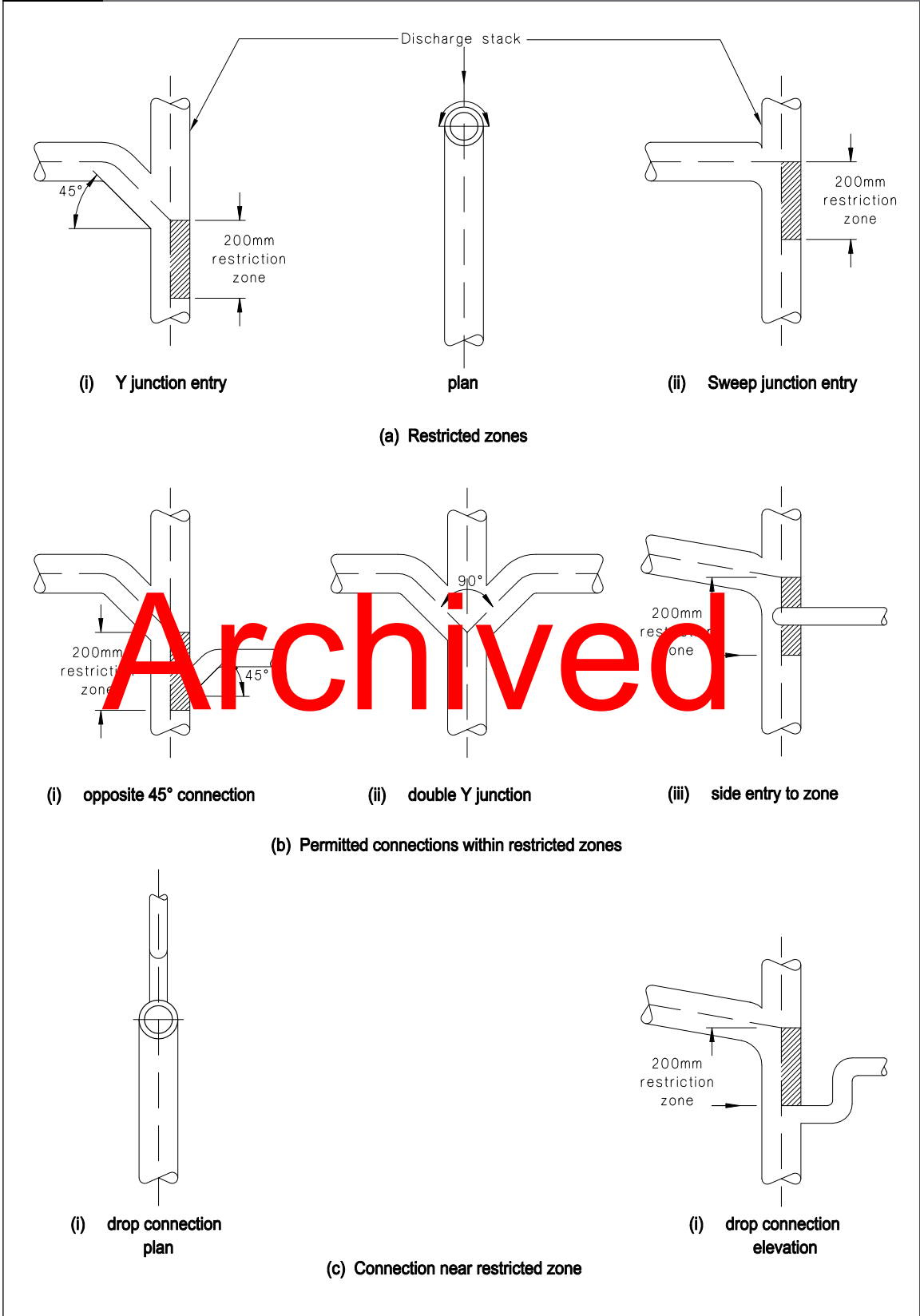

Figure 10: Acceptable methods of vent pipe installation
Paragraphs 5.2.1 and 5.8.4

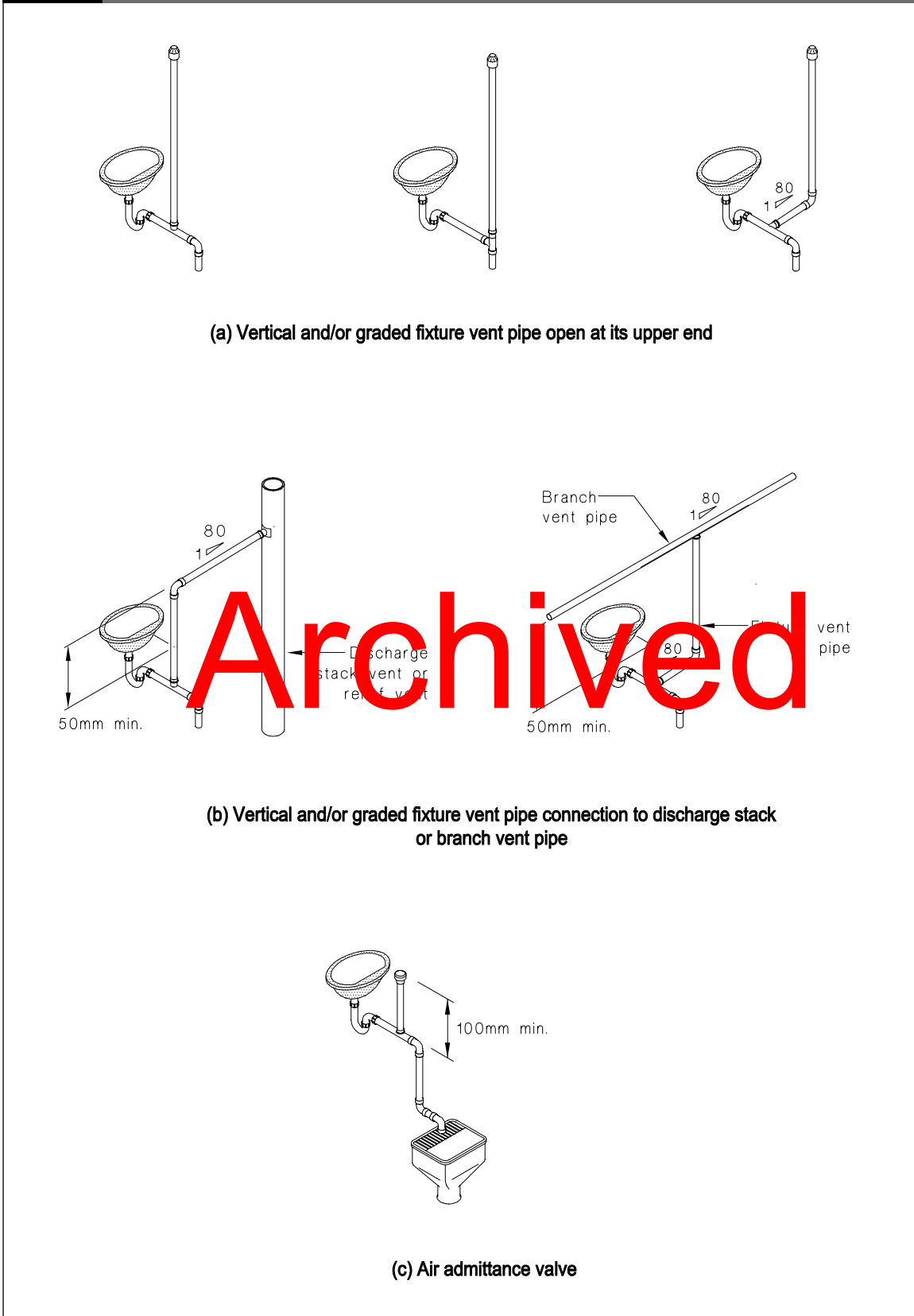

Table 6: Vent pipe sizes
Paragraphs 5.3.1, 5.6.1, 5.6.3 c) and Table 5, G13/AS2 Paragraph 4.2.2 and Table 3

For fixture vent pipes	
Diameter of fixture discharge pipe (mm)	Minimum diameter of fixture vent pipe (mm)
32	32
40	32
50	40
65	40
80	40
100	40
For branch vent, branch drain vent, relief vent (see Note) and discharge stack vent pipes	
Maximum discharge units connected to the discharge pipe	Minimum diameter of open vent pipe (mm)
Up to 15	40
16 to 65	50
66 to 376	65
More than 376	80
For main drain vents	
Maximum discharge units connected to the discharge pipe	Minimum diameter of open vent pipe (mm)
Not applicable	80

Note:

Relief vent sizes are acceptable for a maximum developed length of 12 m

Archived

5.4 Gradient of vent pipes

5.4.1 *Fixture vent pipes* and *branch vent pipes* shall extend upwards from the point of connection to the *fixture discharge pipe* to the open atmosphere, or to an *air admittance valve*, with a gradient of not less than 1:80.

5.5 Connection of vents to fixture discharge pipes

5.5.1 The *fixture vent pipe*, when required by Table 5 for *fixtures* discharging to a *gully trap*, shall connect to the *waste pipe* at a point between 75 mm and 3.5 m from the crown of the *water trap*, as shown in Figure 11 (a).

5.5.2 The *fixture vent pipe*, when required by Table 5 for *fixtures* discharging to a *stack* or directly to the drainage system, shall connect:

- a) If serving a WC pan:
 - i) to the vent horn of the pan, or
 - ii) to the *discharge pipe* within 1.5 m of the crown of the trap, and not less than 300 mm above any bend at the base of a vertical drop (see Figure 6(2)).
- b) If serving a basin or bidet: at a point between 75 mm and either (see Figure 11 (b)):
 - i) 600 mm from the crown of the *water trap*, or
 - ii) before the first bend in the *fixture discharge pipe*.
- c) If serving other *fixture discharge pipes*: at a point between 75 mm and 1.5 m from the crown of the *water trap*, provided that the connection is not less than 300 mm above any bend at the base of a vertical drop within the *fixture discharge pipe* (see Figure 11 (b)).

Figure 11: Acceptable location for connection of fixture vent pipes to fixture discharge pipes
Paragraphs 5.5.1, 5.5.2 b) c)

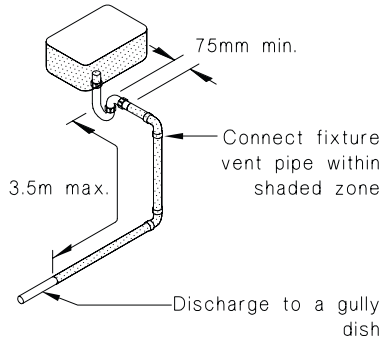

(a) Waste pipes discharging to a gully dish

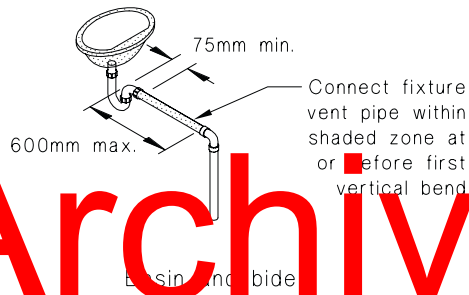

Archived

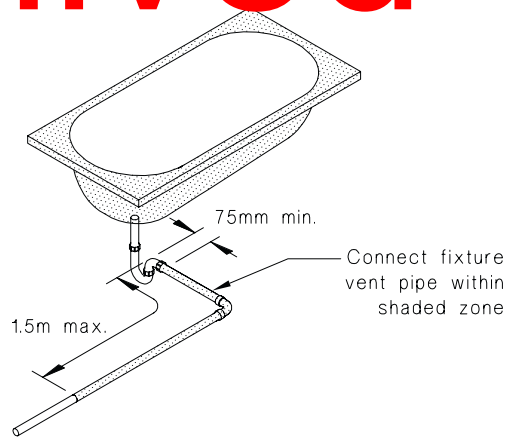
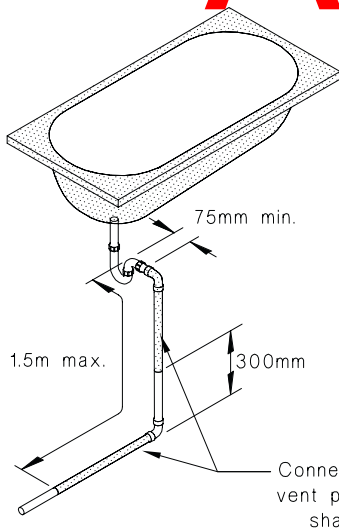

See figure 6 for vent connections to soil fixture discharge pipes.

Sanitary fixtures other than basins and bidets

(b) Fixture discharge pipes discharging to a discharge stack

5.6 Discharge stack and relief vents

5.6.1 The *discharge stack vent*, if also acting as a *drain vent pipe* shall have a *diameter* of not less than 80 mm. Where not acting as a *drain vent* the *discharge stack vent pipe* shall have a *diameter* of not less than that required in Table 6.

5.6.2 Every *discharge stack* serving *sanitary fixtures* or *sanitary appliances* from 3 floors within a *building* shall include a *relief vent pipe* as shown in Figure 7.

5.6.3 *Relief vent pipes* shall:

- a) Connect to the bottom of the *discharge stack* at no less than 300 mm below the lowest *discharge pipe* served, and at an angle of 45°, as shown in Figure 7,
- b) Be extended upwards at a gradient of no less than 1:80 to connect to the *discharge stack vent*, as shown in Figure 7, or extend separately to the atmosphere as an open vent, and
- c) Have a *diameter* of no less than that given in Table 6.

5.7 Termination of open vent pipes

5.7.1 Open *vent pipes* shall terminate outside the *building* in accordance with Paragraphs 5.7.2 and 5.7.3 or 5.7.4.

5.7.2 *Vent pipes* shall terminate outside the *building* and:

- a) Be at a height of not less than 50 mm above the overflow level of the highest *sanitary fixture* they serve, and

COMMENT:

The height of 50 mm above the overflow level is to ensure that the *vent pipe* does not convey *foul water* in the event of the *discharge pipe* becoming blocked.

- b) Incorporate a means to prevent the entry of birds and vermin and shall have an open area not less than 80% of the cross-sectional area of the *vent pipe* they serve.

5.7.3 Open *vent pipes* serving *discharge pipes* directly connected to the *foul water drainage system* shall terminate no closer to *building elements* than (see Figure 12):

- a) Ground level – 3.0 m above,
- b) Windows and other openings – 600 mm above, and 3.0 m below and horizontally,
- c) Roofs – 150 mm above,
- d) Decking having pedestrian access – 3.0 m above, below and horizontally,
- e) Eaves or parapets – 600 mm above, below and horizontally, and
- f) Air intakes – 5.0 m in any direction.

COMMENT:

These requirements reduce the likelihood of foul air from the *foul water drainage system* entering the *building*.

5.7.4 *Fixture vent pipes* serving *waste pipes* discharging to a *gully trap* shall:

- a) Terminate outside the *building* and be not less than 900 mm from any opening to the *building*, and
- b) Be vented to the atmosphere independently of any *vent pipe* system connected directly to the *foul water drainage system*.

COMMENT:

The location of the outlet of the *vent pipe* serving a *waste pipe* is less restrictive than the requirements for *vent pipes* serving *discharge pipes* connected directly to the *drain*. This is permitted because a *waste pipe* is not connected directly to the *foul water drainage system*, and hence a source of foul air.

2. An independent vent pipe system for *waste pipes* is needed to avoid the risk of *sewer gases* escaping through a *waste pipe* to a *gully trap*.

5.8 Air admittance valves

5.8.1 General

Air admittance valves may be used as venting where specified in accordance with Table 5.

5.8.2 *Air admittance valves* shall be manufactured to ASSE 1050, ASSE 1051 or EN 12380.

5.8.3 Size of air admittance valves

The *air admittance valve* shall be no smaller in *diameter* than the *vent pipe* that it serves.

Figure 12: Restricted location for the termination of vent pipes
Paragraph 5.7.3

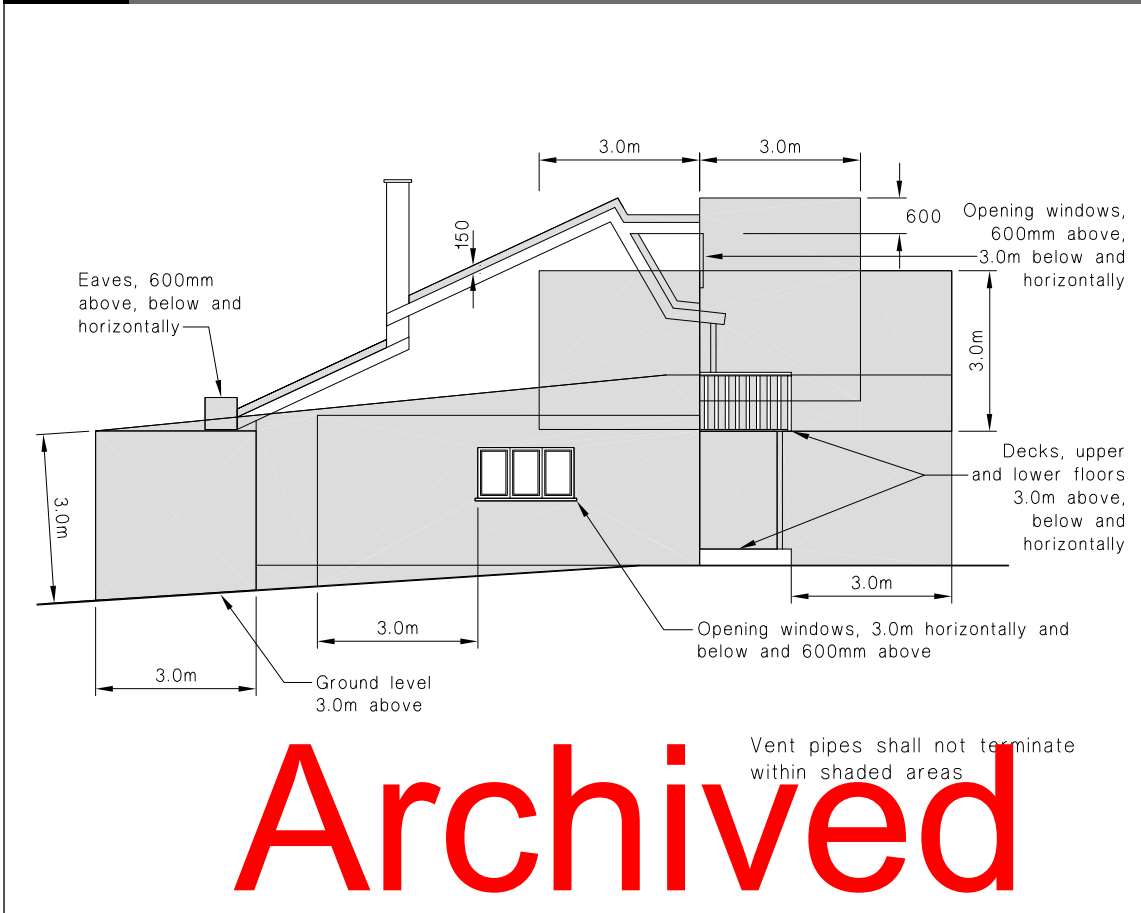

5.8.4 Location

Air admittance valves shall be installed in an upright (vertical) position at least 100 mm above the weir of the *fixture* trap and in a location (see Figure 10 (c)):

- a) Accessible for maintenance and inspection,
- b) Where the valve is unlikely to become frozen,
- c) Protected from likely damage, and
- d) Where *adequate* air can enter the valve.

Ventilated openings shall be provided for *air admittance valves* installed within a wall space. The free area of the openings shall be not less than 1.5 times that of the *vent pipe*.

COMMENT:

A significant amount of ventilating pipework and roof penetrations may be avoided with the use of *air admittance valves*. However the pipework sizing, whether for individual *fixture* vents or branch vents, should follow the requirements of this Acceptable Solution. *Air admittance valves* are intended for anti-siphon situations and may not protect the **water seals** of traps in positive pressure situations.

6.0 Installation

6.1 Jointing methods

6.1.1 Jointing methods for PVC-U pipe shall comply with AS/NZS 2032.

Amend 3
Sep 2010

6.2 Pipe supports

6.2.1 Pipes shall be supported at centres not exceeding those in Table 7.

Amend 3
Sep 2010

6.2.2 For PVC-U pipes carrying discharges of greater than 60°C, support for the pipe shall be in accordance with Paragraph 6.3.2 of AS/NZS 2032.

Amend 3
Sep 2010

COMMENT:

Supports are required to ensure that the pipe gradient does not fall below minimum values given in Paragraph 4.2.1.

6.3 Thermal movement

6.3.1 The *plumbing system* shall accommodate without failure the expected longitudinal movement in pipes resulting from temperature changes. All copper and PVC-U pipes shall incorporate expansion joints. The provisions described in Section 6.4 of AS/NZS 2032 shall be used for PVC-U pipes.

Amend 3
Sep 2010

Amend 3
Sep 2010

6.3.2 At supports, and at wall and floor penetrations not incorporating expansion joints, movement shall be accommodated using pipe sleeves or a durable and flexible lagging material.

COMMENT:

1. Thermal expansion will cause a 10 m length of PVC-U to extend 0.8 mm for each 1°C rise of pipe temperature.
2. Provision for thermal movement by correctly locating expansion joints, with fixed and sliding supports, prevents damage to pipes and *fixtures*.

Amend 3
Sep 2010

6.4 Fire separation

6.4.1 Fire stopping shall be fitted to pipes passing through fire separations in accordance with C/AS1 Appendix C Paragraph C7.1.2.

7.0 Watertightness

7.1 Test methods

7.1.1 All above ground sanitary plumbing pipework shall be tested by water test or air test to verify that the system is watertight.

7.1.2 Water test: The method described in AS/NZS 2032 may be used for ensuring watertightness of above ground sanitary plumbing pipework.

7.1.3 Air tests may be carried out in accordance with either clause 12.3.2 of AS/NZS 3500.2.2 or Paragraph 8.3 of E1/VM1.

Amend 3
Sep 2010

Archived

Erratum 1
Jun 2007

Table 7: Distances Between Supports Paragraph 6.2.1			
Material	Pipe diameter (mm)	Maximum distance between supports (m)	
		Vertical pipe	Graded pipe
Copper pipes	32 to 50	3.0	2.5
	greater than 50	3.5	3.0
PVC-U pipes	32 to 50	1.0	0.5
	65 to 100	1.2	1.0
	greater than 100	1.8	1.2

Amend 3
Sep 2010

Archived

Verification Method G13/VM2 Drainage

1.0 Drainage

1.0.1 No specific methods have been adopted for verifying compliance with the Performance of NZBC G13.

COMMENT:

AS/NZS 3500.2 is referenced in G13/AS3.

Amend 5
Feb 2014

Archived

Archived

Acceptable Solution G13/AS2 Drainage

1.0 Scope

1.0.1 This Acceptable Solution is for below ground non-pressure (gravity flow) *foul water drains* having a *diameter* of no greater than 150 mm.

1.0.2 It does not apply to *foul water drainage systems* where it is necessary to dispose of industrial liquid wastes, chemical or toxic wastes and other wastes which cannot be discharged to a *sewer* without pre-treatment. See G14/MM1.

2.0 Materials

2.0.1 Materials for drainage pipes and joints shall comply with the appropriate standards shown in Table 1.

2.1 Fill materials

2.1.1 Fill materials, as shown in Figure 7, shall be:

- a) Bedding material of clean granular non-cohesive material with a maximum particle size of 20 mm,

- b) Selected fill of fine-grained soil or granular material that is free from topsoil and rubbish and has a maximum particle size of 20 mm, or
- c) Ordinary fill of excavated material.

3.0 Design

3.1 Bends

3.1.1 To reduce the risk of blockages, the *foul water drainage system* shall:

- a) Have a simple layout that incorporates the least number of changes of direction,
- b) Use bends having a radius of the practical maximum, and
- c) Be laid only in straight lines between bends or junctions (both horizontally and vertically).

3.2 Junctions

3.2.1 Any connection to a *drain*, excluding *vent pipe* connections, shall be made by means of *wells* or *oblique junctions*. The angle that the *branch* makes at the point of entry with the *main drain*, shall be no greater than 60° (see Figure 1).

Archived

Table 1: Materials for drainage pipes
Paragraphs 2.0.1 and 5.3.1

	Material	Manufacturing Standard	Installation Standard
Amend 3 Sep 2010	Cast iron	BS 437	
	Concrete	AS/NZS 4058	
	Steel	NZS 4442 or AS 1579	
Amend 3 Sep 2010	PVC-U	AS/NZS 1260	AS/NZS 2032
Amend 4 Oct 2011	Polyethylene	AS/NZS 4130, AS/NZS 2065	AS/NZS 2033
	Polypropylene	AS/NZS 2065	AS/NZS 2566
Amend 3 Sep 2010	Ductile iron	AS/NZS 2065	
	ABS	AS/NZS 3518	
	Copper	NZS 3501	
	GRP	AS 3571	
	FRC	AS 4139	
Amend 3 Sep 2010	Elastomeric rings	NZS/BS 2494 or AS 1646	

Figure 1: Connection of drains
Paragraph 3.2.1

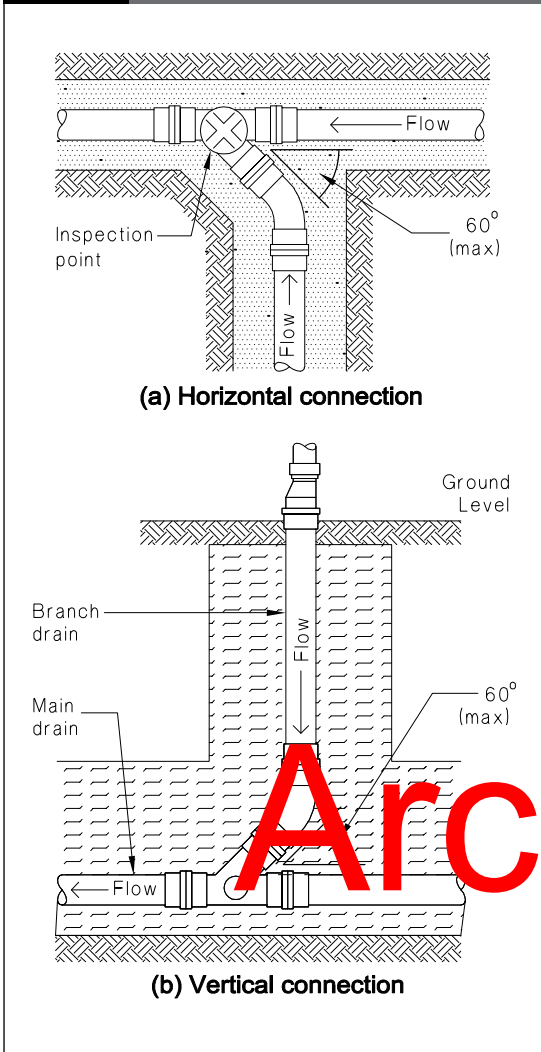
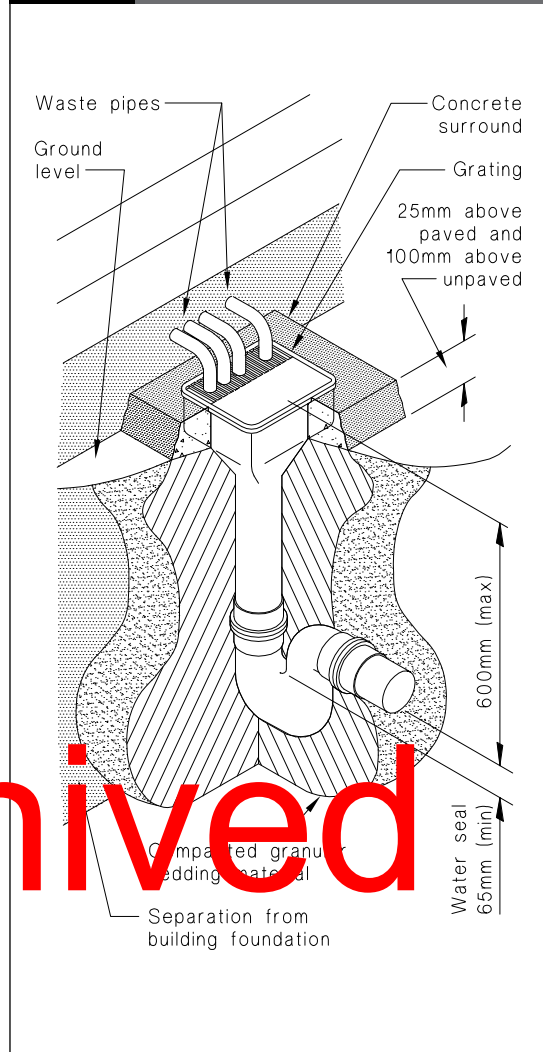

Figure 2: Details of gully traps
Paragraph 3.3.1



Archived

3.3 Gully traps

3.3.1 All *gully traps* shall be constructed to prevent the ingress of *surface water* and foreign bodies likely to cause a blockage, shall be located within the legal boundary of the land on which the *building* is erected, and shall have (see Figures 2 and 3):

- a) The overflow level of the gully dish no less than:
 - i) 25 mm above paved surfaces, or
 - ii) 100 mm above unpaved surfaces,

COMMENT:

It is imperative that the *waste pipe* connections to the *gully trap* remain watertight to prevent the ingress of ground/surface water.

- b) A grating that will allow surcharge,
- c) A minimum outlet pipe *diameter* of 100 mm,
- d) A *water seal* depth of at least 65 mm,
- e) At least one *discharge pipe* discharging to the *gully trap* to avoid *water seal* evaporation,
- f) *Waste pipes* that discharge to the *gully trap* arranged to permit easy cleaning of the *gully trap*,
- g) *Waste pipe* outlets located at least 20 mm above *water seal* level, and at least 20 mm below the grating,

Figure 3: Methods of connecting to gully traps
Paragraph 3.3.1

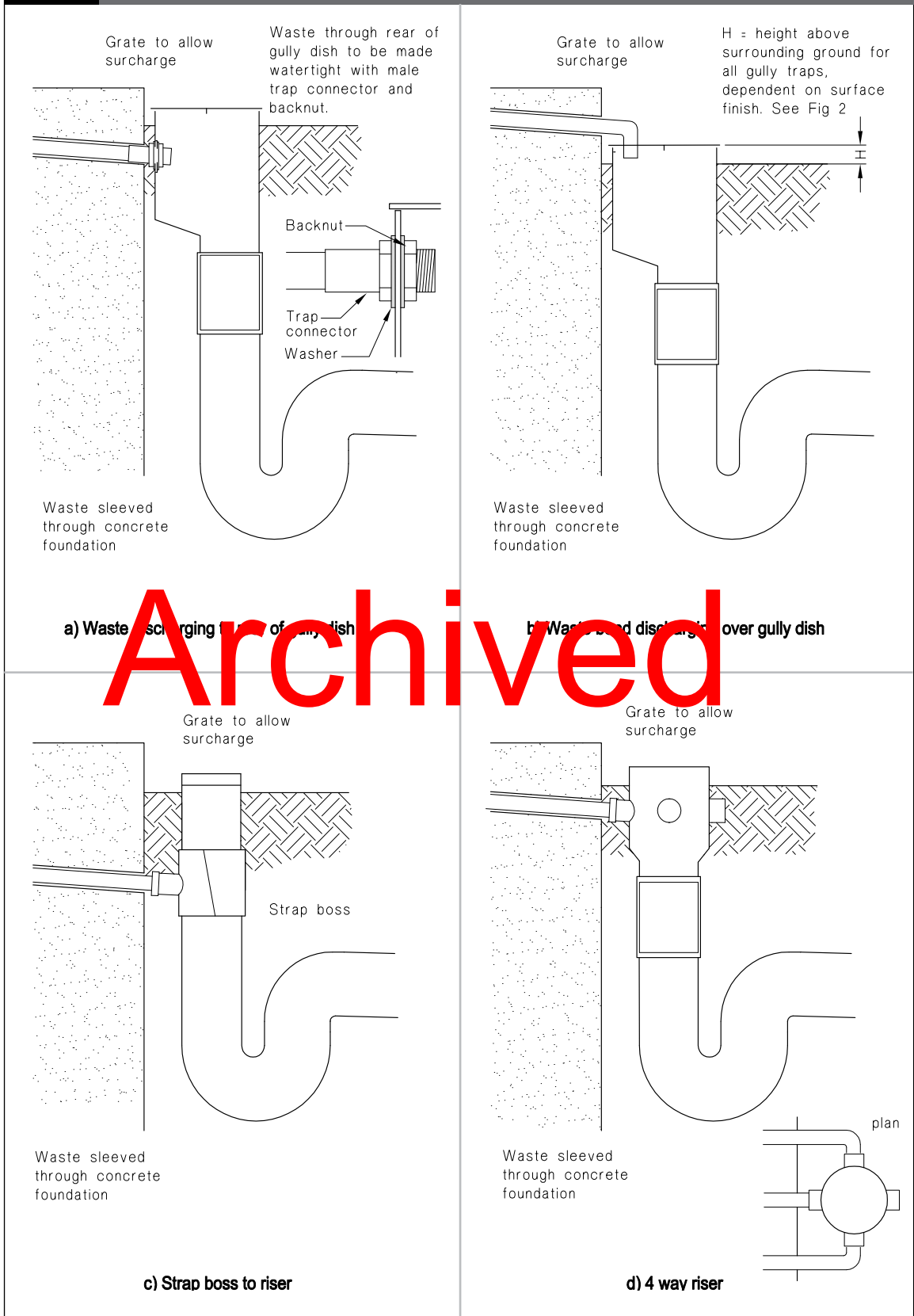

Archived

- h) The top of the *water seal* no more than 600 mm below the top of the gully dish, and

COMMENT:

To permit the *gully trap* to be easily cleaned by hand.

- i) *Adequate* support from bedding and backfilling with:
 - i) concrete no less than 75 mm thick surrounding the entire gully dish and which is separated from the *building* foundation, where the *gully trap* is likely to be damaged, or
 - ii) compacted bedding material complying with Paragraph 2.2.1, in other areas, and
- j) A minimum of 600 mm clear access space above the gully dish.

3.3.2 In order to provide overflow relief for the drainage system, every *building* used for Housing shall be provided with at least one *gully trap* which shall:

- a) Be positioned so that the top of the gully dish is no less than 150 mm below the overflow level of the lowest *sanitary fixture* served by the drainage system.
- b) Have a grating that will allow surcharge,
- c) Be located in a visible position, and
- d) Be installed so that surcharge cannot enter into or under *buildings*.

3.4 Grease traps

3.4.1 *Grease traps* shall be provided for any *discharge pipe* serving a sink(s) where the *foul water* discharges to a soak pit.

3.4.2 In *buildings* other than Housing, *grease traps* shall be provided where waste water is likely to convey grease.

3.4.3 The capacity of a *grease trap* shall be at least twice the capacity of all *sanitary fixtures* and *sanitary appliances* discharging to it, and in no case less than 100 litres as shown in Figure 4.

3.4.4 For restaurants and cafés, the capacity of the *grease trap* shall be at least 5 litres for each person for whom seating is provided, and in no case less than that required by Paragraph 3.4.3.

3.4.5 *Grease traps* located outside a *building* shall be configured as shown in Figure 4.

3.4.6 The top of the outlet junction shall be extended to finished ground level and fitted with a watertight *rodding point* access cover as shown in Figures 4 and 10.

3.4.7 Other types of *grease trap* such as those that separate or digest grease must be approved by the *network utility operator* as required by G14/VM1 1.2.

3.5 Gradient of drains

3.5.1 *Drains* shall:

- a) Be laid at an even grade, and
- b) Have no obstructions to flow.

3.5.2 *Drains* shall be installed at the maximum practicable gradient.

3.5.3 The gradient of drainage pipes shall be not less than that required in Table 2 for the relevant *discharge unit* loading.



Table 2: Drain discharge unit loading and minimum gradients
Paragraphs 3.5.3, 3.6.3 and 5.2.1

Diameter (mm)	Minimum gradient									
	1:20	1:40	1:60	1:80	1:100	1:120	1:140	1:160	1:180	1:200
80	215	100	61	44	34	-	-	-	-	-
100	515	255	205	149	122	104	-	-	-	-
150	2920	1790	1310	1040	855	760	677	611	558	515

See Paragraph 5.2.2 for *drains* laid at gradients within shaded area.

Figure 4: Grease traps – up to 150 litre capacity
Paragraphs 3.4.3, 3.4.5, 3.4.6

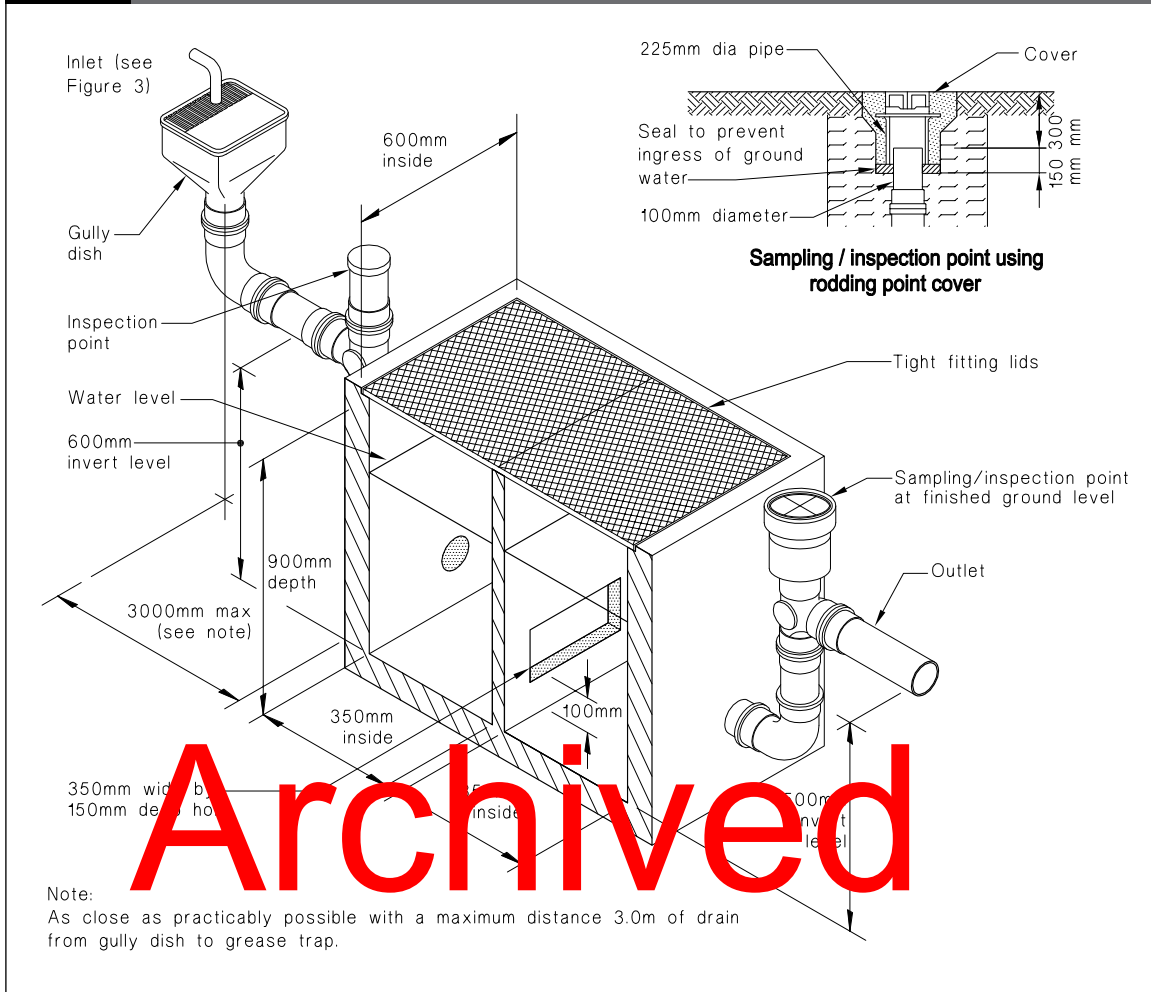

Table 3: Venting Requirements for Drains
Paragraph 4.1.2

Stacks acting as drain vent

Stack vent: All stacks discharging to a *drain* require an open vent, sized in accordance with Table 6 in G13/AS1. Venting with an *air admittance valve* is permitted only on second and subsequent stacks as at least one open vent (the stack vent, if acting as main *drain* vent) is required to ventilate the *drain*.

Venting of main drains

Main *drains* discharging to the *sewer* or to an on-site disposal system are required to be vented with a minimum 80 mm open vent.

Venting of branch drains

Branch *drains* connected to a vented *drain* that exceed 10 m in length require venting with an open vent, sized in accordance with Table 6 in G13/AS1.

3.6 Diameter of drains

3.6.1 The *diameter* of a *drain* shall not decrease in size in the direction of flow.

3.6.2 *Drains* shall have a *diameter* of not less than 100 mm, except that 80 mm is acceptable where the *drain* serves only *waste water fixtures*.

3.6.3 *Diameters* and gradients of *drains* shall be no less than those given in Table 2 for the calculated *discharge unit* loading determined from Table 2 of Acceptable Solution G13/AS1 "Sanitary Plumbing".

4.0 Drain Ventilation

4.1 Ventilation requirements

4.1.1 The drainage system shall be ventilated to allow a flow of air and to minimise the build up of foul air.

4.1.2 Every main *drain*, and every branch *drain* longer than 10 m, shall be ventilated in accordance with Table 3.

4.1.3 Ventilation shall be provided by a *drain vent pipe* located so that the length of *drain* upstream of the *drain vent* connection is less than 10 m (see Figure 5).

4.1.4 To allow for regular flushing of the *drain vent* connection, it shall be located downstream of, but not more than 10 m, from the discharge connection closest to the head of the *drain* (see Figures 5 (a) and 6).

COMMENT:

The head of the *drain* is that point on the drainage system that is the furthest from the *outfall*.

4.1.5 Any open *discharge stack vent* that is located within 10 m from the head of the *drain* may be used as a *drain vent* (see Figure 5 (b)).

4.2 Diameter of drain vent pipe

4.2.1 A main *drain vent* shall have a minimum *diameter* of 80 mm, and shall comply with termination requirements of Paragraph 5.7.3 of G13/AS1 "Sanitary Plumbing".

4.2.2 Branch *drain vents* shall be sized in accordance with Table 6 in G13/AS1.

5.0 Installation

5.1 Jointing

5.1.1 Rigid pipes shall have flexible joints to resist damage from differential settlement.

5.1.2 Jointing for PVC-U pipes and fittings shall be in accordance with the methods described in AS/NZS 2032.

Amend 3
Sep 2010

Amend 3
Sep 2010

5.2 Construction

5.2.1 *Drains* shall be constructed to withstand the combination and frequency of loads likely to be placed upon them without collapse, undue damage or undue deflection (see Figure 7). In addition, *adequate* support needs to be provided to prevent gradients becoming less than those required by Table 2 as a result of:

- a) Differential settlement, or
- b) Deflection of an unsupported span.

5.2.2 Where *drains* are laid at gradients of 1:80 or less, verifiable levelling devices shall be used to ensure uniform and accurate gradients.

COMMENT:

Laser and dumpy levels are recommended devices.

5.3 Construction methods

5.3.1 Figure 7 gives acceptable methods for the bedding and backfilling of the drainage pipes listed in Table 1 except where:

- a) The trench is located within or above peat,
- b) Scouring of the trench is likely due to unstable soils,
- c) The horizontal separation between any *building* foundation and the underside of the pipe trench is less than that required by Paragraph 5.7.1, or
- d) The cover H to the pipe is more than 2.5 m.

Figure 5: Position of drain vent pipe
Paragraphs 4.1.3, 4.1.4 and 4.1.5

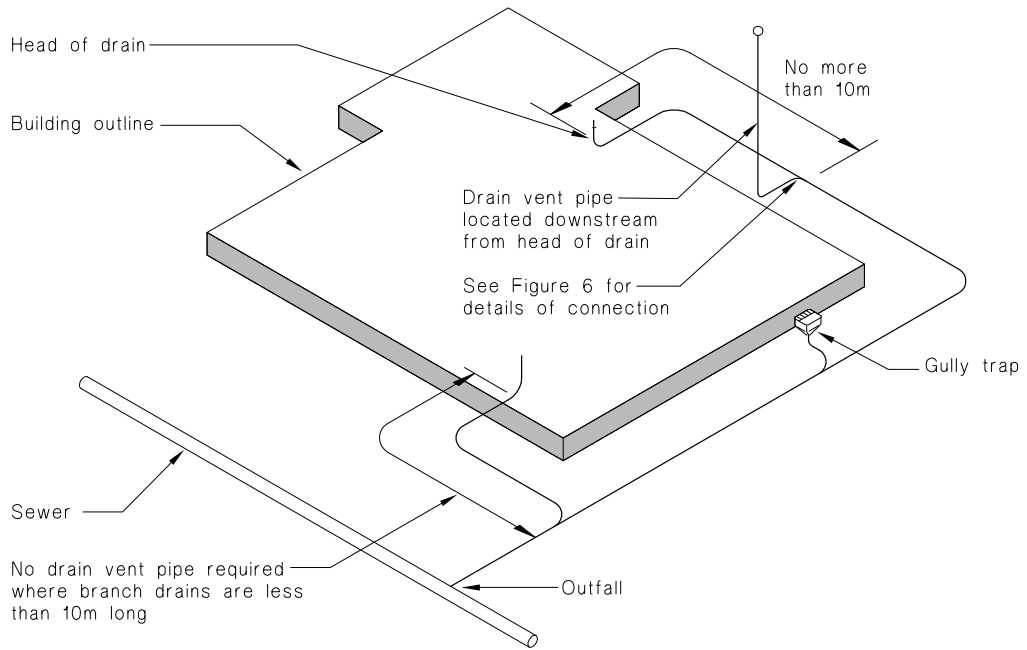

(a) Drain vent pipe

Archived

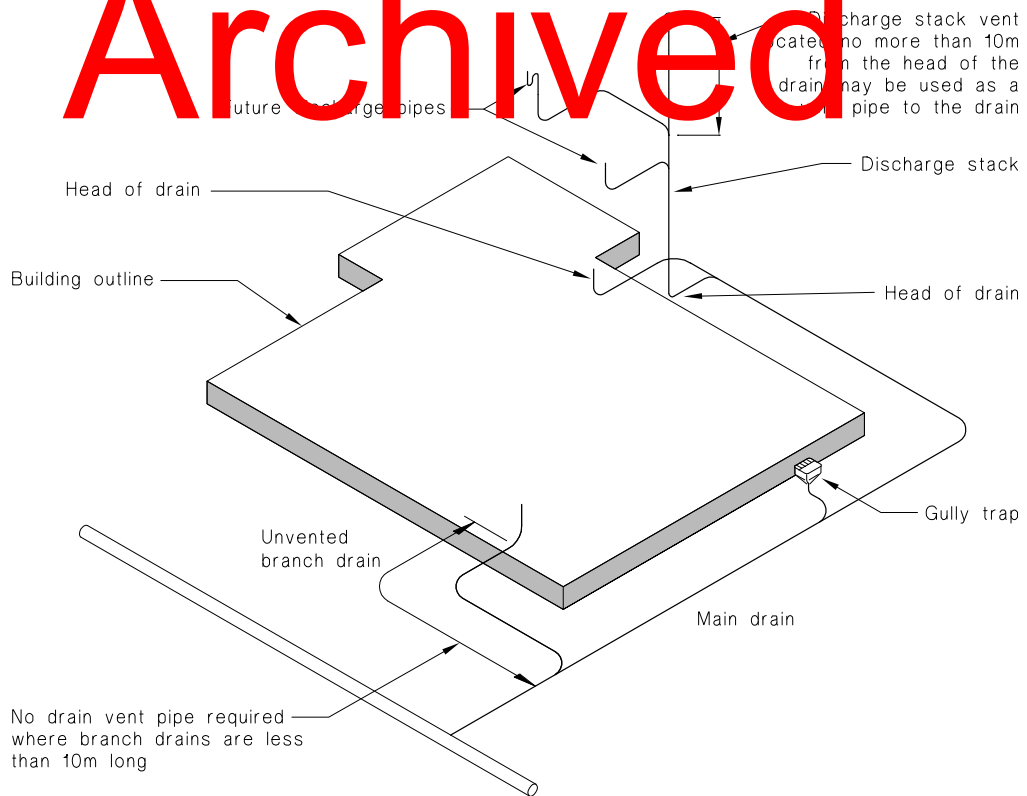

(b) Discharge stack used to ventilate drain

Figure 6: Typical drain vent connection
Paragraph 4.1.4

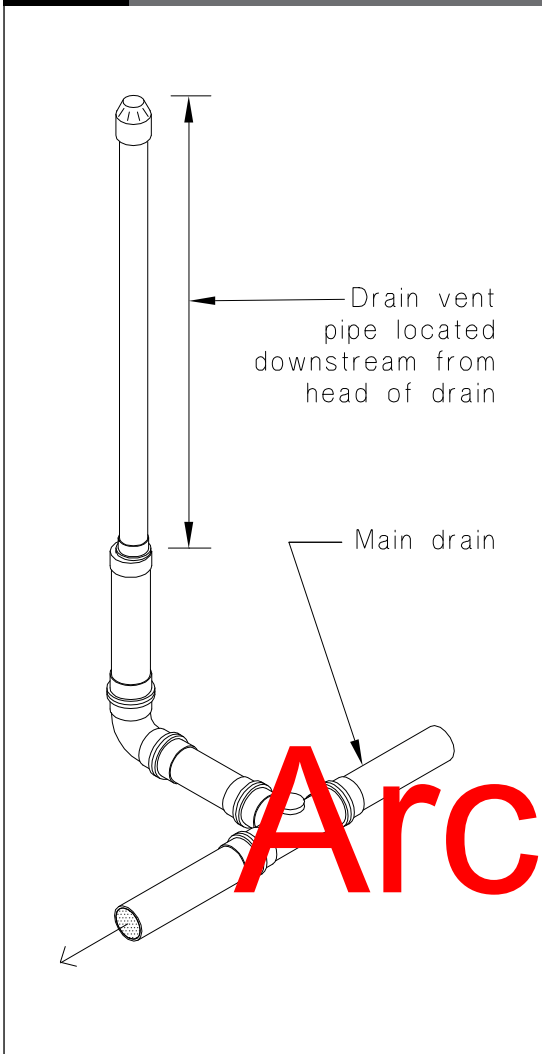

5.3.2 Drains laid in ground described in Paragraph 5.3.1 shall be subject to specific design.

5.4 Trench width

5.4.1 The width B of the trench shall be no less than the pipe *diameter* D plus 200 mm. The width of the trench at the top of the pipe shall be no more than 600 mm unless the pipes in the trench are covered with concrete, as shown in Figure 7 (c).

5.5 Placing and compacting

5.5.1 Base bedding (beneath the pipe) shall be placed and compacted before pipes are laid.

5.5.2 Side bedding (along both sides of the pipe) and cover bedding (where used) up to 300 mm above the pipe, shall be compacted.

5.6 Proximity of trench to building

5.6.1 For light timber framed and concrete masonry *buildings* constructed to NZS 3604 or NZS 4229 in accordance with B1/AS1 pipe trenches which are open for no longer than 48 hours shall be located no closer than V to the underside of any *building* foundation, as shown in Figure 8. Where the trench is to remain open for periods longer than 48 hours the minimum horizontal separation shall increase to 3V in all ground except rock.

Amend 5
Feb 2014

5.7 Access points

5.7.1 Except in accordance with Paragraphs 5.8 and 5.9, all *drains* shall be laid to allow easy access for maintenance and the clearance of blockages.

5.7.2 Drains shall be provided with *access points* to facilitate cleaning and the clearance of blockages. Such *access points* shall be constructed to prevent the ingress of ground water and tree roots.

5.7.3 *Access points* may comprise *access chambers, inspection chambers, rodding points* or *inspection points*. Methods of *access point* construction are shown in Figures 9 to 12.

COMMENT:

Rodding points are preferred to *inspection points* in landscaped or sealed areas and within *buildings*.

Figure 7: Bedding and backfilling
Paragraphs 5.2.1, 5.3.1 and 5.4.1

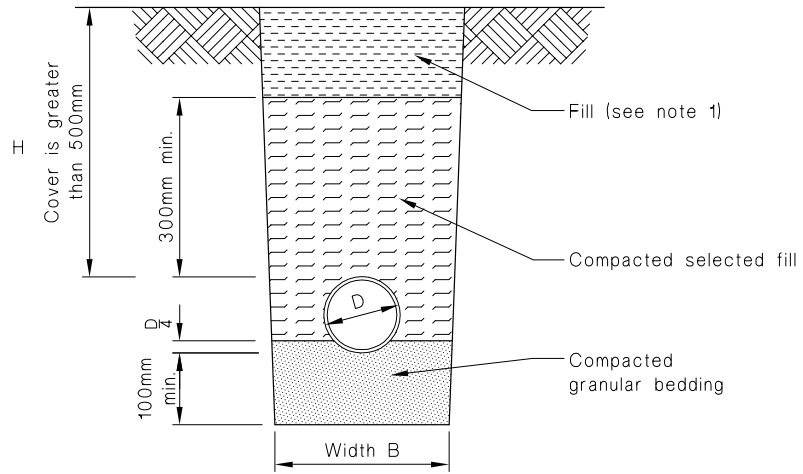

(a) Bedding type 'B' of NZS 7643

Cover greater than 500mm

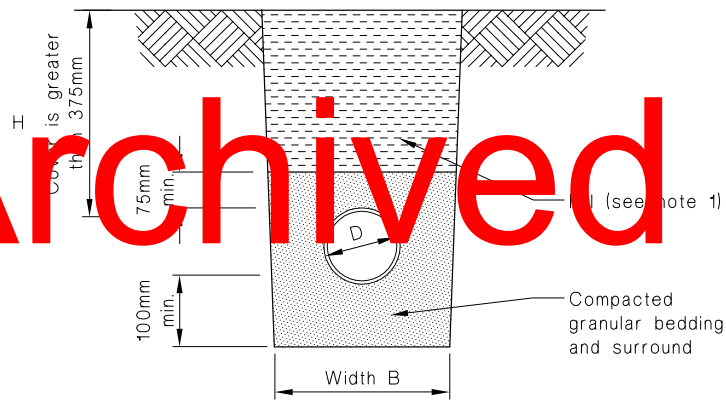

(b) Bedding type 'D' of NZS 7643

Cover greater than 375mm

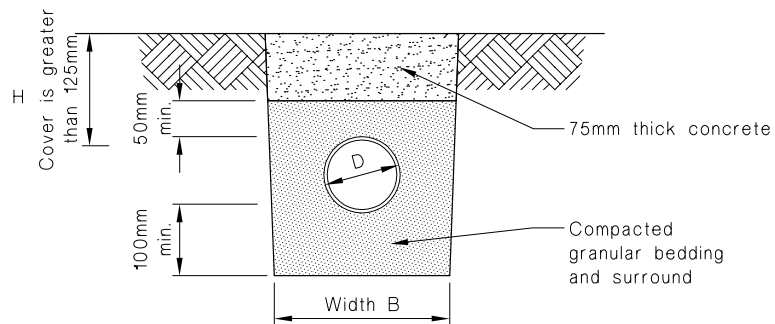

(c) Cover between 125mm and 375mm

NOTE:

1. Fill shall be:

-Ordinary fill where drains are located below gardens and open country.

-Compacted selected fill where the drains are located below residential driveways and similar areas subject to light traffic.

Archived

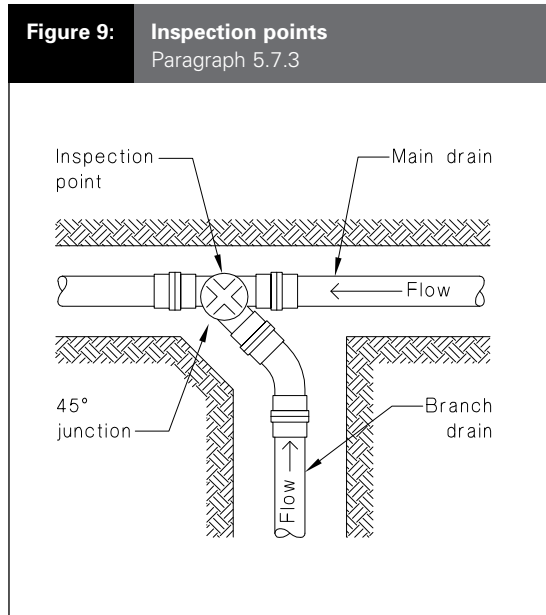
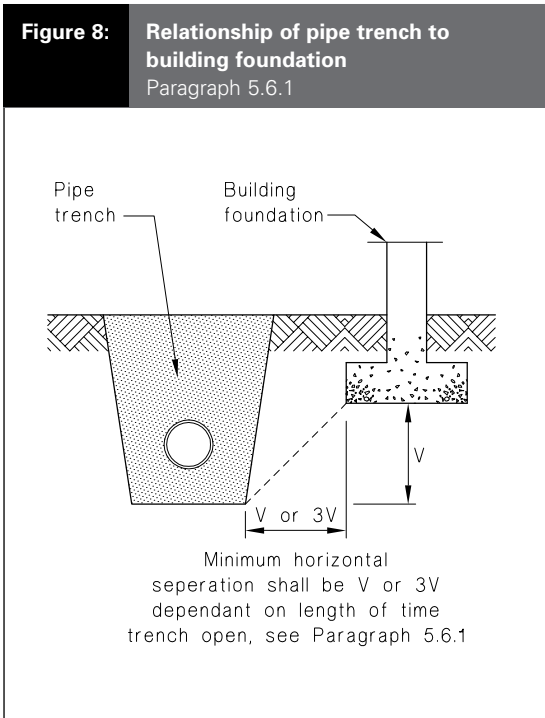

5.7.4 Access points shall be provided at the following locations:

- a) Immediately prior to *drain outfalls*,
- b) Immediately inside the boundary of the property served,
- c) At the junction of every *drain* with another *drain* except that no *access point* is required where the branch *drain* is less than 2.0 m long and only serves a *gully trap*,
- d) Every change in horizontal direction of greater than 45°,
- e) Every change in gradient greater than 45°,
- f) At intervals (on straight lines) of no less than:
 - i) 50 m where *rodding points* are used, or
 - ii) 100 m where *access chambers*, *inspection chambers* or *inspection points* are used, and
- g) Within 2.0 m outside the *building* where a *drain* enters or exits from under a *building*.

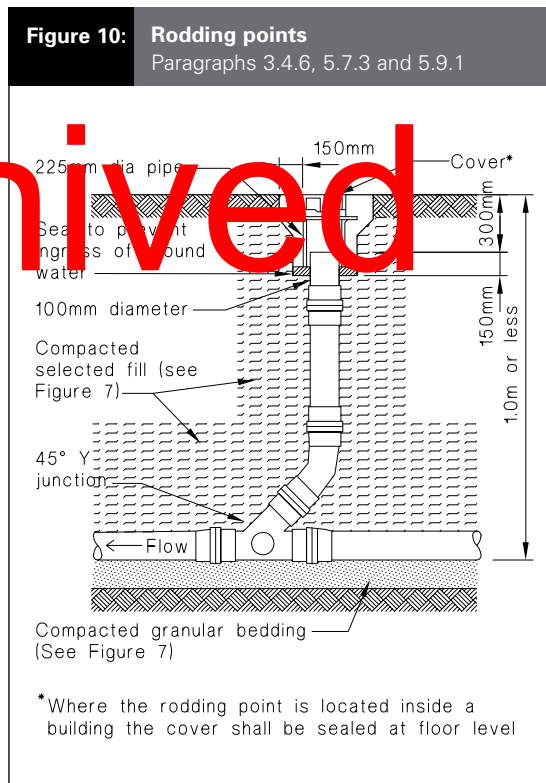

Archived

Figure 11: Inspection chambers
Paragraph 5.7.3

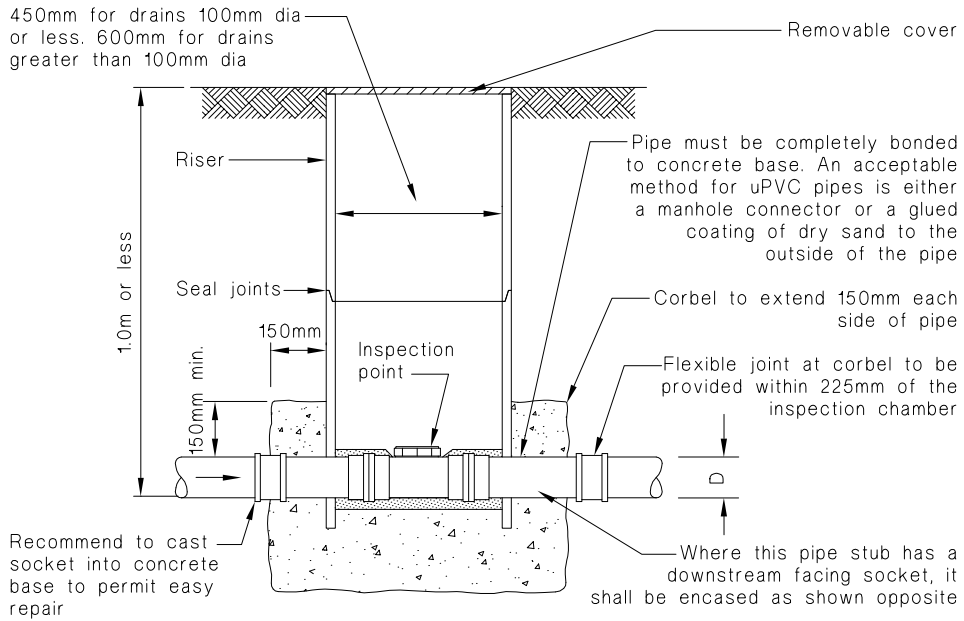

(a) Circular inspection chamber with inspection point

Archived

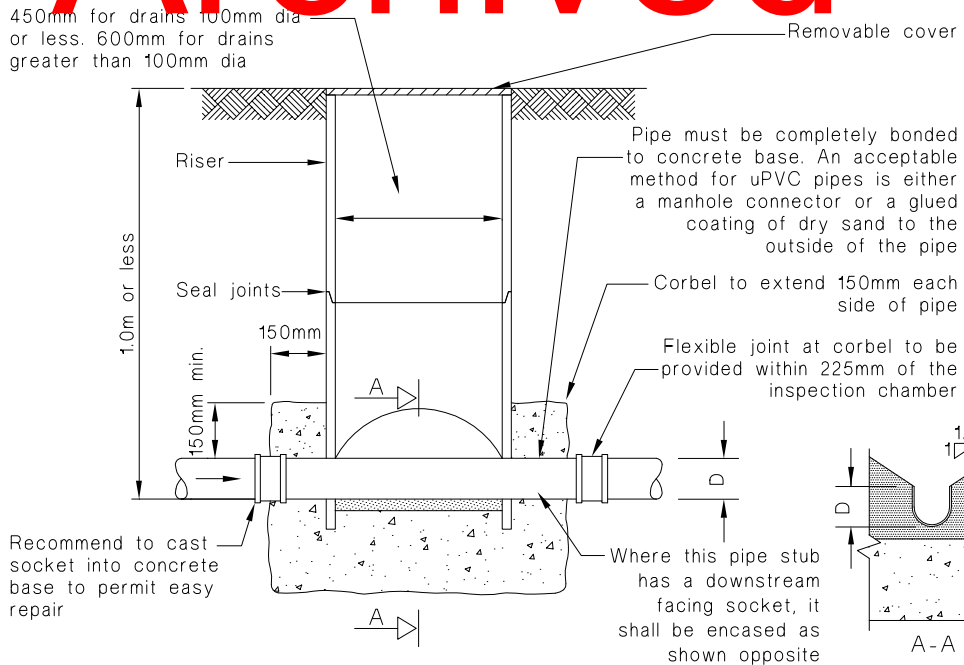

(b) Circular inspection chamber with open drain

Figure 12: Access chambers
Paragraph 5.7.3

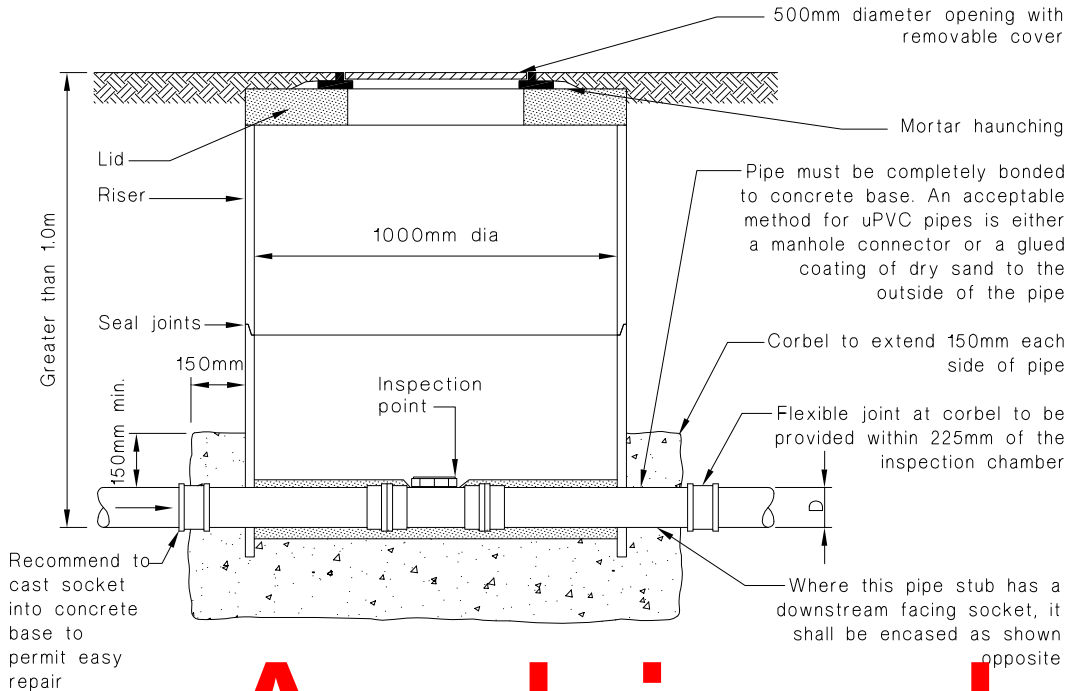

(a) Circular access chamber with inspection point

Archived

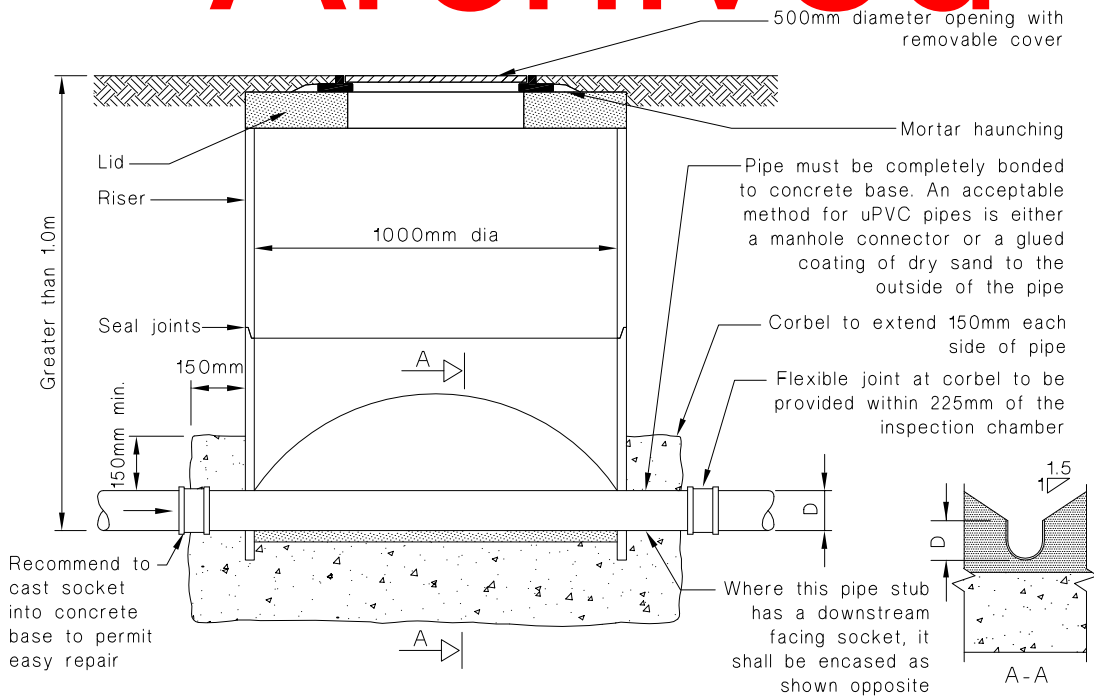

(b) Circular access chamber with open drain

5.8 Additional requirements for drains installed under buildings

5.8.1 Drains installed under buildings shall be:

- a) Straight and of even gradient,
- b) Separated from the building foundation by at least 25 mm, and
- c) When passing through concrete, sleeved or wrapped in a durable and flexible material to allow for expansion and contraction.

5.8.2 Drains passing beneath buildings with a concrete slab on the ground floor shall have in addition to Paragraph 5.8.1:

- a) 50 mm clearance from the top of the pipe to the underside of the slab, and
- b) Junctions beneath the building joining at an angle of not more than 45° (see Figure 13).

COMMENT:

Drains located under buildings must meet the Durability Performance requirement of B2.3.1 (a), that is the life of the building being not less than 50 years.

5.9 Access to drains under buildings

5.9.1 Where two or more soil fixtures are connected to a branch drain beneath the building, access for cleaning shall be provided by a sealed floor level rodding point located downstream of the highest fixture connection to the branch drain (see Figures 10 and 13).

5.9.2 Access points located within a building shall be in an area that complies with the isolation and ventilation requirements for spaces in which soil fixtures are located.

COMMENT:

Refer to G1/AS1 "Personal Hygiene" and G4/AS1 "Ventilation".

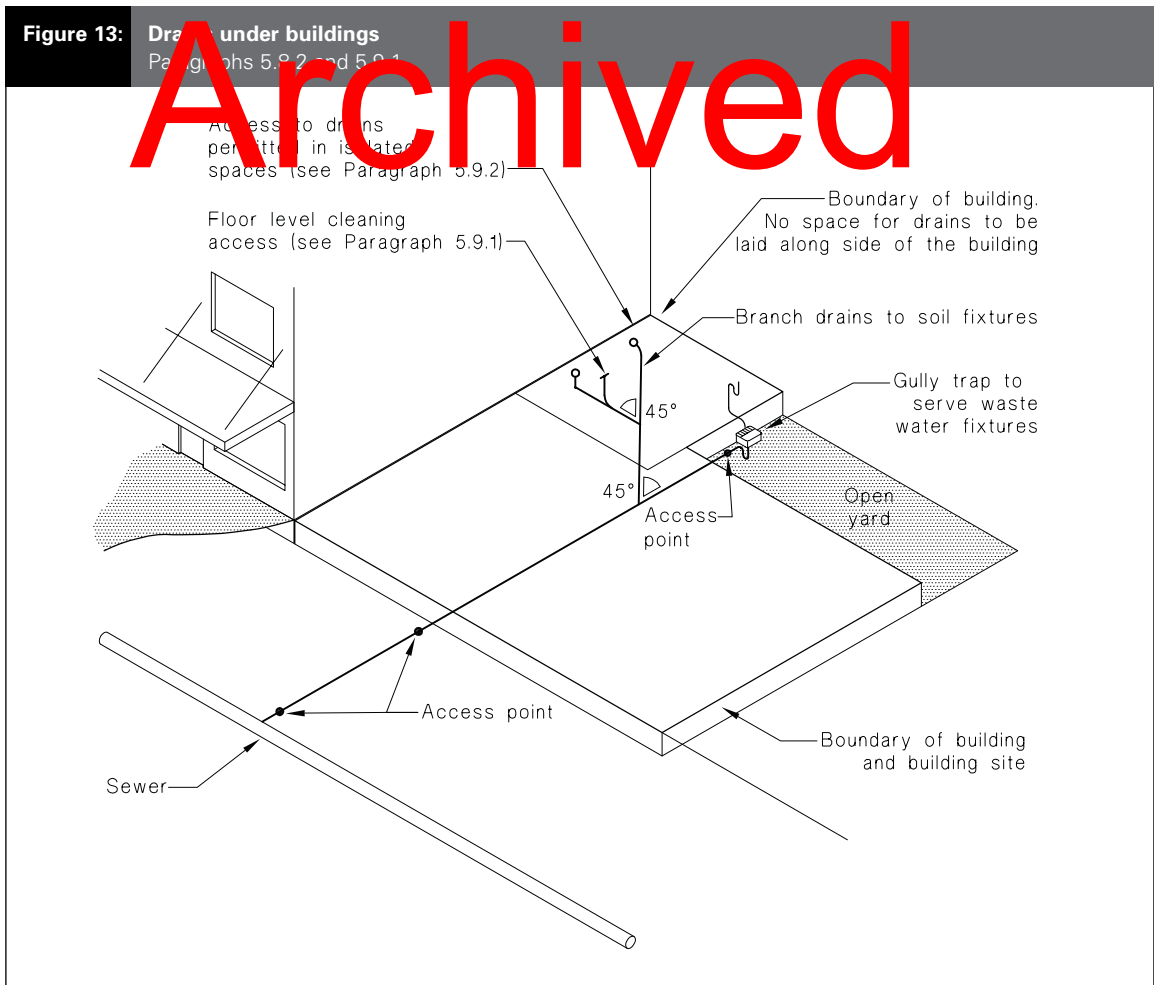

5.9.3 *Access points* may be located in a space containing a *soil fixture*.

5.10 Disused drains

5.10.1 Where a *drain* or part of a *drain* is no longer required, it shall be disconnected from the *foul water drainage system* at the junction with the live *drain* or at the property boundary.

5.10.2 The live *drain* shall be sealed by either of the following *methods*:

- a) Purpose made junctions sealed with a tight-fitting plug that is fixed securely in place and does not protrude into the live *drain*, or
- b) In in-situ formed junctions, where disused branch *drains* which have been inserted into an existing length of pipe, these shall be cut off as close as practicable to the junction and sealed with a purpose made cap, plug or stopper. Alternatively, the length of pipe into which the branch *drain* was inserted may be replaced.

COMMENT:

The unsatisfactory disconnection of old branch *drains* from live *drains* can lead to a source of major infiltration of ground water into the drainage system.

Archived

6.0 Watertightness

6.1 Testing

6.1.1 All sections of the drainage system shall be tested by water test or air test to ensure watertightness.

COMMENT:

Testing should be undertaken before backfilling for the easy identification of any leaks.

6.1.2 Water test

Amend 3
Sep 2010 | AS/NZS 2032 Section 11 gives an acceptable method for ensuring watertightness of below ground PVC-U drainage pipework.

6.1.3 Air tests may be carried out in accordance with either clause 12.3.2 of AS/NZS 3500.2.2 or Paragraph 8.3 of E1/VM1.

6.1.4 Where a disused *drain* is being reinstated, the disused *drain* shall be tested to verify that the *drain* is sound.

Erratum 1
Jun 2007

Acceptable Solution G13/AS3

Plumbing and drainage

1.0 Installation of PVC-U pipe

1.0.1 AS/NZS 2032 is an Acceptable Solution for the installation of PVC-U pipe and fittings, but may exceed the performance criteria of NZBC G13.

1.0.2 AS/NZS 3500.2

AS/NZS 3500.2, Sections 1, 2, 3, 4, 5, 6, 7, 8, 9, 10, 11 and 13, as modified by Paragraph 1.0.3, is an Acceptable Solution for plumbing and drainage.

1.0.3 Modifications to AS/NZS 3500.2

Clause 2.2 Delete and replace with "Materials and products shall comply with NZBC B2 and G13/AS1 Paragraph 2.0 Materials".

Clause 2.8.7 Delete clause.

Clause 3.5.1 (d) Delete and replace with "Drains shall not be installed in water courses".

Clause 3.16 Delete (a) Mortar jointed vitrified clay pipes shall not be re-used".

Section 3.19 Delete section.

Section 4.4 Replace "inspection shafts" with "access point" in this section.

Clause 4.6.6.1 This applies only to Housing.

Clause 4.8.3 Delete and replace with "Access and inspection chambers shall be as required by G13/AS2."

Clause 5.6 Delete and replace with "Drains in other than stable ground shall be subject to specific design."

Clause 11.2 Replace "AS 1428" with "NZBC G1 or NZS 4121".

Clause 11.3.7 Replace "AS/NZS 3500.1" with "G12/AS1 or AS/NZS 3500.1".

Amend 1
Jun 2007
Amend 3
Sep 2010

Amend 1
Jun 2007

Archived

Amend 5
Feb 2014

Archived

Verification Method G13/VM4 Foul Water: On-Site Disposal

1.0 General

1.1 Scope

1.1.1 This document describes the design methods for systems used for the collection, storage, treatment and disposal of *foul water*.

1.1.2 A design method and construction details given in sections 5.1 to 5.5 and 6.1 to 6.2 of AS/NZS 1547 (and the appendices referred to in these sections), for the treatment of domestic *foul water* for flow rates up to a maximum 14,000 litres/week from a population equivalent of up to 10 persons, may be verified as satisfying the performance criteria of G13 Foul Water.

Amend 5
Feb 2014

Amend 2
Jun 2007

Archived

Archived

Index G13/VM1/VM2 & AS1/AS2

All references to Verification Methods and Acceptable Solutions are preceded by **VM** or **AS** respectively.

Access chambers	see Drains, maintenance access
Access points	see Drains, maintenance access
Basins	AS1 3.3.2, 5.5.2, Table 2
Baths	AS1 Table 2
Bidets	AS1 5.5.2, Table 2
Buildings	
three storey buildings	AS1 Figure 7
Cleaners' sinks	AS1 Table 2
Discharge pipes	AS1 4.5.1, 4.5.2, 4.6, 5.1.1, 5.5, 5.7.3, Figures 6 and 11, Table 4
branch discharge pipes	AS1 Figure 7
diameters	AS1 3.3.2, 4.3, 5.3, Table 6, AS2 3.6, 4.2
fixture discharge pipes	AS1 Figures 7 and 8, Tables 2 and 4
gradient	AS1 4.4, 5.4, AS2 3.5, Table 2
waste pipes	
combined waste pipes	AS1 Figure 5
developed length	AS1 Figures 6 and 8
Discharge stacks	AS1 4.2.2, 5.1, 4.7, 5.3, 5.6, Figures 7 to 9, Tables 3, 4 and 6
	see also Discharge pipes, Pipes
discharge stack vents	AS1 4.7.1, 5.2.1, 5.3.1, 5.6.1, 5.6.3, Figures 7 and 8, Table 6, AS2 4.1.5, Figure 5
Discharge units	AS1 Table 2, AS2 Table 2
Dishwashing machine	AS1 3.3.2 a), Table 2
Drainage system	AS1 5.1.2, 5.5.2, 5.7.3, 5.7.4, AS2 1.0.2, 3.1.1, 3.3.2, 4.1.1, 5.10.1
Drains	AS1 4.2.2, AS2 1.0
bedding and backfilling	AS2 Figure 7
acceptable materials	AS2 Table 1
placing and compacting	AS2 5.5
bends	AS2 3.1
connections	AS2 3.2.1, Figure 1
construction	AS2 5.2, Figure 7
diameter	AS2 3.6, Table 2
disused drains	AS2 5.10
drain vent pipes	AS2 Figure 3, Table 3
gradient	AS1 Table 5, AS2 3.5, Table 2
installation	AS2 5.0, 5.5

Drains (continued)

jointing	AS2 5.1
junctions	AS2 3.2
maintenance access	AS2 5.7
access chambers	AS2 Figure 12
access points	AS2 5.7, Figures 9 to 12
inspection chambers	AS2 Figure 11
inspection points	AS2 5.7, Figure 9
location	AS2 5.7.4
rodding points	AS2 5.7.4, Figure 10
materials	AS2 2.0, Table 1
proximity to buildings	AS2 5.6, Figure 8
under buildings	AS2 5.8, 5.9, Figure 13
ventilation	AS2 4.0, Figures 4 to 6, Table 3
watertightness	AS2 6.1.1

Drinking fountains **AS1** Table 2

Floor outlets **AS1** 3.4

Grease traps **AS2** 3.4

 capacity **AS2** 3.4.3, 3.4.4

Gully traps **AS1** Figures 5 and 7, **AS2** 3.3, Figures 2 and 3

 construction **AS2** 3.3.1, Figure 4

 pipe diameters **AS2** 3.3.1

 overflow relief **AS2** 3.3.2

Inspection chamber see Drains, maintenance access

Inspection points see Drains, maintenance access

Kitchen sinks **AS1** 3.3.2, Figure 2, Table 2

Laundry tubs **AS1** 2.3.2, Figure 2, Table 2

Odours

 foul air **AS1** 3.1.1

On-site disposal **VM4** 1.0

 scope **VM4** 1.1

Pipes see Discharge pipes, Discharge stacks,

 Vent pipes, Waste pipes

 jointing methods **AS1** 6.1.1

 materials **AS1** 2.1.1, Table 1

 supports **AS1** 6.2.1, Table 7

 thermal movement **AS1** 6.3

 watertightness **AS1** 7.0

PVC-U pipe **AS3** 1.0

Restaurants **AS2** 3.4.4

Rodding points see Drains, maintenance access

Archived

Amend 2
Jun 2007

Amend 3
Sep 2010

Amend 3
Sep 2010

Sanitary appliances **AS1** 1.0.2, 3.3.1, Table 2

Sanitary fixtures **AS1** 1.0.2, 3.3.1, Table 2

Showers **AS1** Table 2

Sinks **AS1** Table 2
see also Basins, Cleaners' sinks, Kitchen sinks

Soil fixtures see WC pans

Toilets see WC pans

Urinals **AS1** Table 2

Vent pipes **AS1** 5.2, Figures 5 to 8, 10 and 12,
Table 5, **AS2** Figures 5 and 6
diameters **AS1** Table 6
fixture vent pipes **AS1** 5.2, Figures 5 to 8, 10 and 11,
Tables 5 and 6
gradient **AS1** 5.4
installation **AS1** 5.5 to 5.7, Figures 5 to 8, 10 and 11
relief vent pipes **AS1** 5.6, Figure 7
terminations **AS1** 5.7.3, Figure 12

Verification method **VM1** 1.0.1, **VM2** 1.0.1

Washing machines **AS1** Figure 2, Table 1

Waste disposal units **AS1** Figure 2, Table 1

Waste pipes see Discharge pipes, waste pipes

Water seals **AS1** 1.0.3, 3.2.1, Figure 1, Table 1, **AS2** 3.3.1

Water traps **AS1** 3.0, Figure 1
dimensions **AS1** 3.2.1, Figure 1
location **AS1** 3.3
multiple outlets **AS1** 3.3.2, Figure 2

WC pans **AS1** 3.2.1, Figures 1 and 6, Tables 2 and 5

Archived

Archived