



MINISTRY OF BUSINESS,  
INNOVATION & EMPLOYMENT  
HĪKINA WHAKATUTUKI

# Acceptable Solutions and Verification Methods

For New Zealand Building Code Clause  
**G12 Water Supplies**



## Status of Verification Methods and Acceptable Solutions

Verification Methods and Acceptable Solutions are prepared by the Ministry of Business, Innovation and Employment in accordance with section 22 of the Building Act 2004. Verification Methods and Acceptable Solutions are for use in establishing compliance with the New Zealand Building Code.

A person who complies with a Verification Method or Acceptable Solution will be treated as having complied with the provisions of the Building Code to which the Verification Method or Acceptable Solution relates. However, using a Verification Method or Acceptable Solution is only one method of complying with the Building Code. There may be alternative ways to comply.

Defined words (italicised in the text) and classified uses are explained in Clauses A1 and A2 of the Building Code and in the Definitions at the start of this document.

Enquiries about the content of this document should be directed to:



**MINISTRY OF BUSINESS,  
INNOVATION & EMPLOYMENT**  
HĪKINA WHAKATUTUKI

Ministry of Business, Innovation and Employment  
PO Box 1473, Wellington.6140  
Telephone 0800 242 243  
Email: [info@building.govt.nz](mailto:info@building.govt.nz)

**Verification Methods and Acceptable Solutions  
are available from [www.building.govt.nz](http://www.building.govt.nz)**



**Te Kāwanatanga o Aotearoa**  
New Zealand Government

© Ministry of Business, Innovation and Employment 2023

This document is protected by Crown copyright, unless indicated otherwise. The Ministry of Business, Innovation and Employment administers the copyright in this document. You may use and reproduce this document for your personal use or for the purposes of your business provided you reproduce the document accurately and not in an inappropriate or misleading context. You may not distribute this document to others or reproduce it for sale or profit.

The Ministry of Business, Innovation and Employment owns or has licences to use all images and trademarks in this document. You must not use or reproduce images and trademarks featured in this document for any purpose (except as part of an accurate reproduction of this document) unless you first obtain the written permission of the Ministry of Business, Innovation and Employment.

## Document Status

The most recent version of this document (Amendment 13), as detailed in the Document History, is approved by the Chief Executive of the Ministry of Business, Innovation and Employment. It is effective from 2 November 2023 and supersedes all previous versions of this document.

The previous version of this document (Amendment 12) will cease to have effect on 1 November 2024.

People using this document should check for amendments on a regular basis. The Ministry of Business, Innovation and Employment may amend any part of any Verification Method or Acceptable Solution at any time. Up-to-date versions of Verification Methods and Acceptable Solutions are available from [www.building.govt.nz](http://www.building.govt.nz)

<b>G12: Document History</b>				
	<b>Date</b>	<b>Alterations</b>		
First published	July 1992			
Amendment 1	September 1993	pp. vi–viii, References p. ix, Definitions p. 15, Table 4	p. 16, 4.5.1, 4.5.3 p. 19, 5.2.2 b) p. 22, Table 7	p. 26, Index
Amendment 2	19 August 1994	pp. i and ii, Document History p. v, Contents p. viii, References	p. 3, 2.2.1 e) p. 6, 2.6, 2.6.1 p. 19, 4.13.1, 4.14, 4.14.1	p. 26, 29, Index
Amendment 3	1 December 1995	p. ii, Document History pp. vi–viii, References	p. 5, Table 1 p. 6, 2.5.2	
Second edition published July 2001	Effective from 1 October 2001	Document revised – Second edition issued		
Amendment 4	6 January 2002	pp. 3–5 Code Clause G12		
Amendment 5	25 February 2004	p. 2, Document History p.7, Contents pp. 9–11 References	pp. 23–38, 3.7.1, 3.7.4, 4.1, 6.2.1, 6.3.2–6.15, Figure 13 pp. 43–45 Index	
Amendment 6	23 June 2007	p. 2, Document History, Status pp. 9 and 11, References	p. 13, Definitions p. 15, VM1 1.0.1	
Third edition published October 2007	Effective from 1 December 2007	G12/AS1 amended: p. 27, Table 5 p. 32, 6.5.1 p. 35, 6.9, 6.10	p. 36, 6.11.5 p. 37, 6.14.3 p. 38, 6.15 (deleted) p. 40, 7.5.2	New Acceptable Solution G12/AS2 included
Amendment 7	Published 30 June 2010 Effective from 30 September 2010	p. 2, Document History, Status pp. 3 and 4, Code Clause G12 pp. 7–10, References	p. 17, G12/AS1 2.1.2, Table 1 p. 27, G12/AS1 Table 5 p. 32, G12/AS1 Table 6	p. 41, G12/AS1 9.3.2
Amendment 8	Effective from 10 October 2011 until 14 August 2014	p. 2, Document History, Status pp. 7–10, References p.12, Definitions	p. 21, G12/AS1 3.6.1 p. 23, G12/AS1 3.7.2	p. 41, G12/AS1 9.3.2 p. 43, G12/AS2 1.1.1
Amendment 9	14 February 2014 until 30 May 2017	p. 2A, Document History, Status pp 7, 8, 10 References p. 11 Definitions	p. 17 G12/AS1 2.1.2 p. 27 G12/AS1 Table 5 p. 40 G12/AS1 7.5.2	pp. 44–47, 49–50, 64, G12/AS2 2.1.4, 3.1.1, 3.2.1, 3.6.1, 3.6.2, 7.2.3, Tables 1, 2 and 3
Amendment 10	Effective 1 January 2017 until 31 March 2019	pp. 9, 10 References p.17 G12/AS1 2.2, Table 1 p. 21 G12/AS1 3.6.2	p. 23 G12/AS1 3.7.4 p. 24 G12/AS1 5.2.3 p. 32 G12/AS1 Table 6	p. 35 G12/AS1 6.11.3 p. 43 G12/AS2 1.1.1 p. 51 G12/AS2 4.2.2, 5.0.1
Amendment 11	Effective from 30 November 2018 until 31 October 2019	p. 10 References		
Amendment 12	Effective from 27 June 2019 until 1 November 2024	p. 10 References p. 15 G12/VM1 1.0.1	p. 20 G12/AS1 3.5.2 p. 51 G12/AS2 4.2.2	
<b>Note: Page numbers relate to the document at the time of Amendment and may not match page numbers in current document.</b>				

**G12: Document History** *(continued)*

	<b>Date</b>	<b>Alterations</b>
Amendment 13	Effective 2 November 2023	<p>pp. 2A-2B Document History, Status</p> <p>p. 5, 6 Contents</p> <p>pp. 7-10a References</p> <p>pp. 11-13 Definitions</p> <p>p. 15 G12/VM1 1.0, 1.0.1</p> <p>p. 17 G12/AS1 1.0.1, 2.13, 2.2.1, 2.2.2, 2.2.3</p> <p>p. 18 G12/AS1 Table 1, 3.3.1</p> <p>p. 19 G12/AS1 3.3.2, 3.3.3</p> <p>p. 19A G12/AS1 3.4.5, 3.4.6, 3.5, 3.5.1, 3.5.2, 3.5.3, 3.5.4, 3.6, 3.6.1, 3.6.2</p> <p>p. 19B G12/AS1 Table 2</p> <p>p. 19C G12/AS1 Table 2A</p> <p>p. 20 G12/AS1 3.6.3, 3.6.4, 3.7, 3.7.1, Figure 1</p> <p>p. 21 G12/AS1 3.7.2, 3.7.3, 3.7.4</p> <p>p. 22 G12/AS1 Figure 2</p> <p>p. 23 G12/AS1 3.8, 3.8.1, 3.8.2, 3.7.3 (deleted), 3.8.3, 4.3.1, 4.3.2, 4.3.3, 4.3.4</p> <p>p. 24 G12/AS1 5.1.1, 5.2.2, 5.2.8</p> <p>p. 25 G12/AS1 5.3, 5.3.1, 5.3.2, 5.3.3</p> <p>p. 26 G12/AS1 5.4, 5.4.1, Table 3, Table 4</p> <p>p. 27 G12/AS1 5.4.2 (deleted), 5.5, 5.5.1, 5.5.2, 5.5.3, Figure 5, 6.1.2, 6.2.2</p> <p>p. 28 G12/AS1 Table 5,</p> <p>p. 29 G12/AS1 6.3.3, Figure 7</p> <p>p. 30 G12/AS1 Figures 8(a) and 8(b)</p> <p>p. 31 G12/AS1 Figure 11</p> <p>p. 33 G12/AS1 6.6, 6.6.1, 6.6.2, 6.6.3, 6.6.5</p> <p>p. 33A G12/AS1 6.6.7, 6.6.8, Table 7</p> <p>p. 33B G12/AS1 6.7.2</p> <p>p. 34 G12/AS1 Figure 12, 6.7.6, 6.7.7</p> <p>p. 35 G12/AS1 Figure 13, 6.8.3</p> <p>p. 36 G12/AS1 Figure 14, 6.11.5 (deleted), 6.13.1, 6.13.2 (deleted)</p> <p>p. 37 G12/AS1 Figure 15, 6.14.1, 6.14.2, Figure 16, 6.14.3</p> <p>p. 38 G12/AS1 6.14.3, 6.14.4, 6.14.5, Table 8A, Table 8B</p> <p>p. 38A G12/AS1 Table 9</p> <p>p. 39 G12/AS1 7.1.3, 7.3, 7.3.1, 7.4, 7.4.1, 7.4.2, 7.4.3</p> <p>p. 40 G12/AS1 7.5, 7.5.1, Table 10, 7.6, 7.6.1, 7.6.2, 7.7, 7.7.1</p> <p>p. 41 G12/AS1 Figure 18, 8.0, 8.0.1</p> <p>p. 53 G12/AS2 5.2.5, 5.2.6</p> <p>p. 54 G12/AS2 Figure 6</p> <p>p. 55 G12/AS2 5.3.3</p> <p>p. 64a New Acceptable Solution G12/AS3 included</p> <p>pp. 65-68 Index</p>
<p>Note: Page numbers relate to the document at the time of Amendment and may not match page numbers in current document.</p>		

# New Zealand Building Code

## Clause G12 Water Supplies

The mandatory provisions for building work are contained in the New Zealand Building Code (NZBC), which comprises the First Schedule to the Building Regulations 1992. The relevant NZBC Clause for Water Supplies is G12.

Schedule	Building Amendment Regulations 2001
<p><b>Schedule</b></p> <p><b>New clause G12 substituted in First Schedule of principal regulations</b></p>	
<p><b>Clause G12–Water Supplies</b></p> <p><b>Provisions</b></p> <p><b>Objective</b></p> <p><b>G12.1</b> The objective of this provision is to–</p> <ul style="list-style-type: none"> <li>(a) safeguard people from illness caused by contaminated water:</li> <li>(b) safeguard people from injury caused by hot water system explosion, or from contact with excessively hot water:</li> <li>(c) safeguard people from loss of <i>amenity</i> arising from–                             <ul style="list-style-type: none"> <li>(i) a lack of hot water for personal hygiene; or</li> <li>(ii) water for human consumption, which is offensive in appearance, odour or taste:</li> </ul> </li> <li>(d) ensure that <i>people with disabilities</i> are able to carry out normal activities and functions within <i>buildings</i>.</li> </ul> <p style="margin-left: 400px;">Objective G12.1(d) shall apply only to those <i>buildings</i> to which section 47A of the Act applies.</p>	
<p><b>Functional requirement</b></p> <p><b>G12.2</b> <i>Buildings</i> provided with water outlets, <i>sanitary fixtures</i> or <i>sanitary appliances</i> must have safe and <i>adequate</i> water supplies.</p>	
<p><b>Performance</b></p> <p><b>G12.3.1</b> Water intended for human consumption, food preparation, utensil washing or oral hygiene must be potable</p> <p style="margin-left: 400px;">Performance G12.3.1 does not apply to <i>backcountry huts</i>.</p> <p><b>G12.3.2</b> A potable <i>water supply system</i> shall be–</p> <ul style="list-style-type: none"> <li>(a) protected from contamination; and</li> <li>(b) installed in a manner which avoids the likelihood of contamination within the system and the <i>water main</i>; and</li> <li>(c) installed using components that will not contaminate the water.</li> </ul> <p><b>G12.3.3</b> A non-potable <i>water supply system</i> used for personal hygiene shall be installed in a manner that avoids the likelihood of illness or injury being caused by the system.</p> <p><b>G12.3.4</b> Water pipes and outlets provided with non-potable water shall be clearly identified.</p>	

Amend 7  
Sep 2010  
See Note

Amended  
Oct 2008

**NOTE:**

Section 47A is in the Building Act 1991. The equivalent section in the Building Act 2004 is section 118.

<b>Building Amendment Regulations 2001</b>	<b>Schedule</b>
<p><b>Provisions</b></p> <p><b>Performance</b>—continued</p> <p><b>G12.3.5</b> <i>Sanitary fixtures and sanitary appliances</i> must be provided with hot water when intended to be used for—</p> <ul style="list-style-type: none"> <li>(a) utensil washing; and</li> <li>(b) personal washing, showering or bathing.</li> </ul> <p><b>G12.3.6</b> Where hot water is provided to <i>sanitary fixtures and sanitary appliances</i>, used for personal hygiene, it must be delivered at a temperature that avoids the likelihood of scalding.</p> <p><b>G12.3.7</b> <i>Water supply systems</i> must be installed in a manner that—</p> <ul style="list-style-type: none"> <li>(a) pipes water to <i>sanitary fixtures and sanitary appliances</i> flow rates that are <i>adequate</i> for the correct functioning of those <i>fixtures and appliances</i> under normal conditions; and</li> <li>(b) avoids the likelihood of leakage; and</li> <li>(c) allows reasonable access to components likely to need maintenance; and</li> <li>(d) allows the system and any backflow prevention devices to be isolated for testing and maintenance.</li> </ul> <p><b>G12.3.8</b> Vessels used for producing or storing hot water must be provided with safety devices that—</p> <ul style="list-style-type: none"> <li>(a) relieve excessive pressure during both normal and abnormal conditions; and</li> <li>(b) limit temperatures to avoid the likelihood of flash steam production in the event of rupture.</li> </ul> <p><b>G12.3.9</b> A <i>hot water system</i> must be capable of being controlled to prevent the growth of legionella bacteria.</p> <p><b>G12.3.10</b> Water supply taps must be <i>accessible</i> and usable for <i>people with disabilities</i>.</p>	<p><b>Limits on application</b></p> <p>Performance G12.3.5(b) shall apply only to <i>housing</i>, retirement homes and early childhood centres.</p> <p>Performance G12.3.10 applies only to those <i>buildings</i> to which section 47A of the Act applies.</p>
<p>Clerk of the Executive Council.</p> <hr style="width: 20%; margin: 0 auto;"/>	

Amend 7  
Sep 2010  
See Note

**NOTE:**  
Section 47A is in the Building Act 1991. The equivalent section in the Building Act 2004 is section 118.

# Contents

	<b>Page</b>		
<b>References</b>	<b>7</b>	6.6	Relief valves and expansion vessels 33
<b>Definitions</b>	<b>11</b>	6.7	Relief valve drains 33B
<b>Verification Method G12/VM1</b>	<b>15</b>	6.8	Vent pipes 34
<b>Water Supply Sizing</b>		6.9	Another acceptable solution for the installation of open vented storage water heaters 35
<b>1.0 Water Supply Pipework Sizing</b>	<b>15</b>	6.10	Another acceptable solution for the installation of unvented (valve vented) storage water heaters 35
<b>Acceptable Solution G12/AS1</b>	<b>17</b>	6.11	Water heater installation 35
<b>1.0 Scope</b>	<b>17</b>	6.12	Hot water pipe sizes 36
<b>2.0 Materials</b>	<b>17</b>	6.13	Wet-back water heaters 36
2.1 Water quality	17	6.14	Safe water temperatures 37
2.2 Pipe materials	17	6.15	Energy Efficiency 38
<b>3.0 Protection of Potable Water</b>	<b>18</b>	<b>7.0 Installation Methods</b>	<b>39</b>
3.1 Drawn water not to be returned	18	7.1	Pipe supports 39
3.2 Cross connections prohibited	18	7.2	Protection from freezing 39
3.3 Cross connection hazard	18	7.3	Unintentional heating 39
3.4 Backflow protection	19	7.4	Protection from damage 39
3.5 Containment backflow protection	19A	7.5	Installation of pipework systems 40
3.6 Air gap	20	<b>8.0 Taps for People with Disabilities</b>	<b>41</b>
3.7 Backflow prevention devices	20	<b>9.0 Equipotential Bonding</b>	<b>41</b>
3.8 Testing	23	9.1	General 41
<b>4.0 Non-potable Supply</b>	<b>23</b>	9.2	Installation of equipotential bonding conductors 42
4.1 Protection of non-potable water supplies	23	9.3	Earth bonding conductors 42
4.2 Outlet identification	23	<b>Acceptable Solution G12/AS2</b>	<b>43</b>
4.3 Pipeline identification	23	<b>1.0 Scope</b>	<b>43</b>
<b>5.0 Water Supply</b>	<b>24</b>	1.1	Structural support limitations 43
5.1 Water tanks	24	1.2	Exclusions 44
5.2 Water tank installation	24	<b>2.0 Materials</b>	<b>44</b>
5.3 Water pressure	24	2.1	Material selection 44
5.4 Water pipe size	24	<b>3.0 Solar Water Heater Requirements</b>	<b>48</b>
5.5 Maintenance facilities	26	3.1	Solar water heaters and components 48
<b>6.0 Hot Water Supply System</b>	<b>27</b>	3.2	Solar controller 48
6.1 Water heaters	27	3.3	Sizing of systems 48
6.2 Water supply to storage water heaters	27	3.4	Operating and safety devices 48
6.3 Operating devices	28	3.5	Protection from Legionella bacteria 48
6.4 Safety devices	33		
6.5 Temperature control devices	33		

Amend 13  
Nov 2023

Amend 13  
Nov 2023

Amend 13  
Nov 2023

Amend 13  
Nov 2023

Amend 13  
Nov 2023

Amend 13  
Nov 2023

Amend 13  
Nov 2023

Amend 13  
Nov 2023

Amend 13  
Nov 2023

	<b>Page</b>
3.6 Protection from frosts	49
<b>4.0 Location of Solar Water Heaters</b>	<b>50</b>
4.1 Location	50
4.2 Solar orientation and inclination	50
<b>5.0 Installation of Solar Water Heaters</b>	<b>51</b>
5.1 Wetback water heaters	51
5.2 Weathertightness	52
5.3 Pipe installation	55
5.4 Pipe insulation	55
<b>6.0 Structural Support for Solar Water Heaters</b>	<b>56</b>
6.1 Scope	56
6.2 General requirements	56
6.3 Direct fixed solar collectors parallel to the roof	56
6.4 Elevated solar collectors parallel to the roof	59
6.5 Collector support rails	61
6.6 Mounting collectors at a different pitch to the roof cladding	62
<b>7.0 Maintenance and Durability</b>	<b>64</b>
7.1 Maintenance	64
7.2 Durability	64
<b>Acceptable Solution G12/AS3</b>	
<b>1.0 AS/NZS 3500.1 and AS/NZS 3500.4</b>	<b>64A</b>
<b>Index</b>	<b>65</b>

Amend 13  
Nov 2023



# References

For the purposes of New Zealand Building Code (NZBC) compliance, the Standards and documents referenced in these Verification Methods and Acceptable Solutions (primary reference documents) must be the editions, along with their specific amendments, listed below. Where these primary reference documents refer to other Standards or documents (secondary reference documents), which in turn may also refer to other Standards or documents, and so on (lower-order reference documents), then the version in effect at the date of publication of these Verification Methods and Acceptable Solutions must be used.

Amend 8  
Oct 2011Amend 9  
Feb 2014Amend 9  
Feb 2014

## Standards New Zealand

## Where quoted

Amend  
7, 8, 13

NZS 3501: 1976	Specification for copper tubes for water, gas, and sanitation <i>Amends: 1, 2, 3</i>	AS1 Table 1
----------------	---	-------------

Amend 8  
Oct 2011

NZS 3604: 2011	Timber framed buildings	AS2 1.1.1
NZS 3604: 1999	Timber framed buildings	AS2 1.1.1
NZS 3604: 1990	Timber framed buildings	AS2 1.1.1
NZS 4203:1992	Code of Practice for general structural design and design loadings for buildings	AS2 1.1.1

Amend 13  
Nov 2023

NZS 4305: 1996	Energy efficiency – domestic type hot water systems	AS1 6.15 Comment
NZS 4602: 1988	Low pressure copper thermal storage electric water heaters <i>Amend: 1</i>	AS1 Table 5

NZS 4603: 1985	Installation of low pressure thermal storage electric water heaters with copper cylinders (open-vented systems) <i>Amend: 1</i>	AS1 6.9.1, 6.13.1
----------------	--	-------------------

Amend 13  
Nov 2023

NZS 4606: Part 1: 1989	Storage water heaters General requirements <i>Amends: 1, 2, 3</i>	AS1 Table 5
Part 2: 1989	Specific requirements for water heaters with single shells <i>Amend: A</i>	AS1 Table 5
Part 3: 1992	Specific requirements for water heaters with composite shells <i>Amend: A</i>	AS1 Table 5

NZS 4607: 1989	Installation of thermal storage electric water heaters: valve-vented systems	AS1 6.10.1
----------------	--	------------

NZS 4608: 1992	Control valves for hot water systems	AS1 Table 6
----------------	--------------------------------------	-------------

Amend 9  
Feb 2014

NZS 4613: 1986	Domestic solar water heaters	AS2 7.2.3
----------------	------------------------------	-----------

		Where quoted
Amend 9 Feb 2014	NZS 4614: 1986 Installation of domestic solar hot water heating systems <i>Amend: 1 (1986) Erratum</i>	AS2 4.2.2
	NZS 4617: 1989 Tempering (3-port mixing) valves	AS1 Table 8B
	NZS 6214: 1988 Thermostats and thermal cutouts for domestic thermal storage electric water heaters (alternating current only)	AS1 6.5.1
Amend 7, 8, 13		
	<b>British Standards Institution</b>	
	BS EN 1111: 2017 Sanitary tapware. Thermostatic mixing valves (PN-10). General technical specification	AS1 Table 8A & 8B
Amend 13 Nov 2023	BS EN 1287: 2017 Sanitary tapware. Low pressure thermostatic mixing valves. General technical specification	AS1 Table 8A & 8B
	BS EN 1490: 2000 Building valves. Combined temperature and pressure relief valves. Tests and requirements.	AS1 Table 6
	BS EN 1491: 2000 Building valves. Expansion valves. Tests and requirements	AS1 Table 6
	BS EN 1567: 1999 Building valves. Water pressure reducing valves and combination water reducing valves. Requirements and tests.	AS1 Table 6
Amend 13 Nov 2023	BS 6920 Suitability of non-metallic products for use in contact with water intended for human consumption with regard to their effect on the quality of the water	
	Part 1: 2014 Specification	AS1 2.1.2
Amend 7 Sep 2010	Part 2: 2014 Methods of tests	AS1 2.1.2
	Part 3: 2000 High temperature tests	AS1 2.1.2
Amend 13 Nov 2023	BS EN 13831: 2007 Closed expansion vessels with built-in diaphragm for installation in water	AS1 6.6.7 a)
	<b>Standards Australia</b>	
	AS 1308: 1987 Electric water heaters – Thermostats and thermal cut-outs <i>Amend: 1</i>	AS1 6.5.1
Amend 7 Sep 2010	AS 1357: Valves primarily for use in heated water systems	
	Part 1: 2019 Protection valves	AS1 Table 6
	Part 2: 2005 Control valves <i>Amend: 1, 2</i>	AS1 Table 6

		Where quoted	
	AS 1432: 2004	Copper tubes for plumbing, gasfitting and drainage applications	AS1 Table 1
	AS 2345: 2006	Dezincification resistance of copper alloys	AS1 2.2.3
	AS 3498: 2020	Safety and public health requirements for plumbing products-Water heaters and hot-water storage tanks	AS1 Table 8B
	AS 3688: 2016	Water supply and gas systems- Metallic fittings and end connectors	AS1 Table 1
	AS 4032:	Water supply- Valves for the control of heated water supply temperatures	
	Part 1: 2005	Thermostatic mixing valves- Materials design and performance requirements	AS1 Table 8A & 8B
	Part 2: 2005	Tempering valves and end-of-line temperature actuated devices <i>Amend: 1, 2</i>	AS1 Table 8B
	Part 3: 2004	Requirements for field testing, maintenance or replacement of thermostatic mixing valves, tempering valves and end of line temperature control devices	AS1 Table 8A & 8B Comment
	Part 4: 2014	Thermostatically controlled taps for the control of heated water supply temperatures	AS1 Table 8A & 8B
	AS 4809: 2017	Copper pipe and fittings- Installation and commissioning	AS1 7.5.3
	AS 5200:	Plumbing and drainage products	
Amend 13 Nov 2023	Part 053: 2008	Stainless steel pipes and tubes for pressure applications	AS1 Table 1
Amend 7 Sep 2010	<b>Australian/New Zealand Standards</b>		
	AS/NZS 1170:	Structural Design Actions	
	Part 0: 2002	General principles <i>Amend: 1, 2 and 4</i>	AS2 1.1.1
	Part 1: 2002	Permanent, imposed and other actions <i>Amend: 1, 2</i>	AS2 1.1.1
	Part 2: 2011	Wind Actions <i>Amend: 1, 2 and 3</i>	AS2 1.1.1
Amend 10 Jan 2017	Part 3: 2003	Snow and ice actions <i>Amend: 1</i>	AS2 1.1.1
	NZS 1170:		AS2 1.1.1
Amend 8 Oct 2011	Part 5: 2004	Earthquake design actions – New Zealand	
	AS/NZS 1477: 2017	PVC pipes and fittings for pressure applications	AS1 Table 1
	AS/NZS 2032: 2006	Installation of PVC pipe systems <i>Amend: 1</i>	AS1 7.5.1, 7.6.2
Amend 7 Sep 2010	AS/NZS 2033: 2008	Installation of polyethylene pipe systems <i>Amend: 1, 2</i>	AS1 7.5.2

	AS/NZS 2492: 2007 Cross-linked polyethylene (PE-X) pipes for pressure applications	AS1 Table 1	
	AS/NZS 2537: Mechanical jointing fittings for use with crosslinked polyethylene (PE-X) for pressure applications		
	Part 1: 2011 Plastics piping systems for hot and cold water installations – Crosslinked polyethylene (PE-X)- General	AS1 Table 1	
	Part 2: 2011 Plastics piping systems for hot and cold water installations – Crosslinked polyethylene (PE-X) – Fittings <i>Amend 1</i>	AS1 Table 1	
	Part 3: 2011 Plastics piping systems for hot and cold water installations – Crosslinked polyethylene (PE-X)- Fitness for purpose of the system	AS1 Table 1	
	Part 4: 2011 Plastics piping systems for hot and cold water installations – Crosslinked polyethylene (PE-X)- Guidance for the assessment of conformity	AS1 Table 1	
Amend 13 Nov 2023	AS/NZS 2642: Polybutylene pipe systems		
	Part 1: 2007 Polybutylene (PB) pipe extrusion compounds <i>Amend 1</i>	AS1 Table 1	Amend 13 Nov 2023
Amend 8 Oct 2011	Part 2: 2008 Polybutylene (PB) pipe for hot and cold water applications	AS1 Table 1	
Amend 8 Oct 2011	Part 3: 2008 Mechanical jointing fittings for use with polybutylene (PB) pipes for hot and cold water applications <i>Amend: 1</i>	AS1 Table 1	
Amend 9 Feb 2014	AS/NZS 2712: 2007 Solar and heat pump water heaters – Design and construction <i>Amend: 1, 2 and 3</i>	AS2 3.1.1, 3.6.1	
Amend 10 Jan 2017			
Amend 10 Jan 2017	AS/NZS 2845: Water supply – Backflow prevention devices		
Amend 8 Oct 2011	Part 1: 2022 Materials, design and performance requirements	AS1 3.6.2	Amend 13 Nov 2023
Amend 10 Jan 2017	Part 3: 2020 Field testing and maintenance of testable devices	AS1 3.6.1 d), 3.7.2	
Amends 10 & 12	AS/NZS 3500: Plumbing and drainage		
Amends 9 & 11	Part 1: 2021 Water services <i>Amend: 1</i>	VM1 1.0.1 Comment AS1 3.5.2 Comment, 5.2.8, 6.14.4 Comment AS3 1.0.1, 1.0.3	Amend 11 Nov 2018
	Part 4: 2021 Heated water services	VM1 1.0.1 Comment, AS1 6.6.8 Comment 6.14.3 Comment, AS2 1.1.1 c), 4.2.2 Comment, 5.0.1 AS3 1.0.1, 1.0.4	Amend 12 Jun 2019  Amend 13 Nov 2023
Amends 9,10,11,12			

		<b>Where quoted</b>
	AS/NZS 3879: 2011 Solvent cements and priming fluids for PVC (PVC-U and PVC-M) and ABS and ASA pipes and fittings	AS1 Table 1
Amend 13 Nov 2023	AS/NZS 4020: 2018 Testing of products for use in contact with drinking water	AS1 2.1.2
Amend 13 Nov 2023	AS/NZS 4129: 2020 Fittings for polyethylene (PE) pipes for pressure applications	AS1 Table 1
Amend 10 Jan 2017	AS/NZS 4130: 2018 Polyethylene (PE) pipes for pressure applications	AS1 Table 1
Amend 7 Sep 2010	<i>Amend: 1</i>	
	AS/NZS 4692: Electric water heaters Part 2: 2005 Minimum Energy Performance Standards (MEPS) requirements and energy labelling	AS2 3.1.2
Amend 7 Sep 2010	AS/NZS 5000.1 2005 Electric cables – Polymeric insulated – For working voltages up to and including 0.6/1 (1.2) kV <i>Amend: 1</i>	AS1 9.3.2
Amend 8 Oct 2011	AS/NZS 5000.2 2006 Electric cables – Polymeric insulated Part 2: For working voltages up to and including 450/750 v.	AS1 9.3.2
Amend 9 Feb 2014	AS/NZS 60335.2.35: 2013 Household and similar electrical appliances. Safety – Part 2.35 Particular requirements for instantaneous water heaters	AS1 Table 5
Amends 7 and 10		
	<b>New Zealand Legislation</b>	
Amend 13 Nov 2023	Water Services Act 2021	Definitions G12/VM1 & AS1/AS2/AS3
	<b>New Zealand Regulations</b>	
Amend 13 Nov 2023	Gas (Safety and Measurement) Regulations 2010	AS1 Table 5
	<b>Master Plumbers, Gasfitters and Drainlayers NZ Inc and Water New Zealand</b>	
Amend 13 Nov 2023	NZ Backflow testing standard 2019	AS1 3.6.1 d), 3.7.2
Amend 8 Oct 2011	Field testing of backflow prevention devices and verification of air gaps	
	<b>Chartered Institute of Plumbing and Heating Engineering</b>	
	Plumbing Engineering Services Design Guide, Hornchurch 2002	VM1 1.0.1 VM1 1.0.1 Comment
	<b>National Sanitation Foundation / American National Standards Institute /Canadian Standards Association</b>	
Amend 13 Nov 2023	NSF/ANSI/CAN 372: 2020 Drinking Water System Components Lead Content	AS1 2.1.3

10B

# Definitions

This is an abbreviated list of definitions for words or terms particularly relevant to these Verification Methods and Acceptable Solutions. The definitions for any other italicised words may be found in the New Zealand Building Code Handbook.

Amend 9  
Feb 2014

**Adequate** *Adequate* to achieve the objectives of the *Building Code*.

**Air gap** The vertical distance through air between the lowest point of the water supply outlet and the *flood level rim* of the equipment or the *fixture* into which the outlet discharges.

**Amenity** means an attribute of a *building* which contributes to the health, physical independence, and well being of the *building's* users but which is not associated with disease or a specific illness.

**Backflow** The unplanned reversal of flow of water or mixtures of water and *contaminants* into the *water supply system*. See *back-siphonage* and *back-pressure*.

**Backflow prevention device** A device that prevents *backflow*.

**Back-pressure** A *backflow* condition caused by the downstream pressure becoming greater than the supply pressure.

**Back-siphonage** A *backflow* condition caused by the supply pressure becoming less than the downstream pressure.

**Building** has the meaning ascribed to it by sections 8 and 9 of the Building Act 2004.

**Check valve** A valve that permits flow in one direction but prevents a return flow and is part of a *backflow prevention device*.

**Cladding** The exterior weather-resistant surface of a *building*.

**COMMENT:**

Includes any supporting substrate and, if applicable, surface treatment.

**Containment backflow protection** *Backflow* protection installed adjacent to the *point of supply* to protect a *water main* from any potential contamination risk posed by *backflow* from a premises.

**COMMENT:**

*Containment backflow protection* is also known as boundary *backflow* protection.

**Contaminant** includes any substance (including gases, liquids, solids, and micro-organisms) or energy (excluding noise) or heat, that either by itself or in combination with the same, similar, or other substances, energy, or heat

- a) When discharged into water, changes or is likely to change the physical, chemical, or biological condition of water, or
- b) When discharged onto or into land or into air, changes or is likely to change the physical, chemical, or biological condition of the land or air onto or into which it is discharged.

This is the meaning ascribed to it by the Resource Management Act 1991.

**Cross connection** Any actual or potential connection between a *potable water* supply and a source of contamination.

**Diameter (or bore)** The nominal internal *diameter*.

**Drinking water standards** means the standards issued or adopted under section 47 of the Water Services Act 2021.

**Early childhood education and care centre** has the meaning ascribed to it by section 10 of the Education and Training Act 2020.

**EPDM** (Ethylene Propylene Diene Monomer) A thermosetting synthetic rubber used as a resilient part of a sealing washer, or as a roof *membrane*.

**Fixture** An article intended to remain permanently attached to and form part of a *building*.

**Flashing** A component, formed from a rigid or flexible *waterproof* material, that drains or deflects water back outside the *cladding system*.

**Flood level rim** The top edge at which water can overflow from equipment or a *fixture*.

Amend 13  
Nov 2023

Amend 13  
Nov 2023

**Framing** Timber members to which *lining, cladding, flooring, or decking* is attached; or which are depended upon for supporting the structure, or for resisting forces applied to it

**Free outlet (push through)** In the context of *storage water heaters* means a *water heater* with a tap on the cold water inlet so designed that the hot water is discharged through an open outlet

#### Household unit

- a) means any *building* or group of *buildings*, or part of a *building* or group of *buildings*, that is:
- i) used, or intended to be used, only or mainly for residential purposes; and
  - ii) occupied, or intended to be occupied, exclusively as the home or residence of not more than one household; but
- b) does not include a hostel, boarding house or other specialised accommodation.

**Masonry tiles** Clay or concrete tile roof *cladding*.

**Membrane** A non-metallic material, usually synthetic, used as a fully supported roof *cladding, deck surface* or, in conjunction with other *claddings*, as gutters or *flashings*.

**Network utility operator** means a person who—

- a) undertakes or proposes to undertake the distribution or transmission by pipeline of natural or manufactured gas, petroleum, biofuel, or geothermal energy; or
- b) operates or proposes to operate a network for the purpose of—
  - i) telecommunication as defined in section 5 of the Telecommunications Act 2001; or
  - ii) radiocommunications as defined in section 2(1) of the Radiocommunications Act 1989; or
- c) is an electricity operator or electricity distributor as defined in section 2 of the Electricity Act 1992 for the purpose of line function services as defined in that section; or

- d) undertakes or proposes to undertake the distribution of water for supply (including irrigation); or
- e) undertakes or proposes to undertake a drainage or sewerage system.

**Non-return valve** A valve that permits flow in one direction but prevents a return flow and is part of a hot or cold water system.

**Open vented storage water heater** A *water heater* incorporating a *vent pipe* which is permanently open to the atmosphere.

**Point of supply** The toby, reservoir float valve, or other final point to which a *building water supply system* supplied from a *water main* connects.

#### COMMENT:

Refer to section 13 of the Water Services Act 2021.

**Potable water** means water that—

- (a) is safe to drink; and
- (b) complies with the *drinking water standards*.

#### COMMENT:

*Potable water* is also known as safe drinking water.

**Purlin** A horizontal member laid to span across *rafters* or trusses, and to which the roof *cladding* is attached.

**Rafter** A *framing* timber, normally parallel to the slope of the roof, providing support for sarking, *purlins* or roof *cladding*.

**Sanitary appliance** An appliance which is intended to be used for *sanitation*, but which is not a *sanitary fixture*. Included are machines for washing dishes and clothes.

**Sanitary fixture** Any *fixture* which is intended to be used for *sanitation*.

**Sanitation** The term used to describe the activities of washing and/or excretion carried out in a manner or condition such that the effect on health is minimised, with regard to dirt and infection.

**Specific design** Design and detailing of a proposed *building* or parts of a *building*, demonstrating compliance with the building code, that shall be provided to the building consent authority for assessment and approval as part of the *building consent* process.

Amend 13  
Nov 2023



*Buildings*, or parts of *buildings*, requiring *specific design* are beyond the scope of this Acceptable Solution.

**Storage water heater** A *water tank* with an integral *water heater* for the storage of hot water.

**Toxic environment** An environment that contains *contaminants* that can contaminate the water supply in concentrations greater than those specified in the *drinking water standards*.

**Valve vented storage water heater** (Also known as an unvented *storage water heater*.) A *storage water heater* in which the required venting to the atmosphere is controlled by a valve.

**Vent pipe** A pipe which is open to the atmosphere at one end and acts as a pressure limiting device.

**Water heater** A device for heating water.

**Water main** A water supply pipe vested in, or is under the control, or maintained by, a *network utility operator*.

**Water supply system** Pipes, fittings and tanks used or intended to be used for the storage and reticulation of water from a *water main* or other water source, to *sanitary fixtures*, *sanitary appliances* and fittings within a *building*.

**Water tank (vessel)** A covered fixed container for storing hot or cold water.

**Weathertightness** and **weathertight** Terms used to describe the resistance of a *building* to the weather.

*Weathertightness* is a state where water is prevented from entering and accumulating behind the *cladding* in amounts that can cause undue dampness or damage to the *building elements*.

**COMMENT:**

The term *weathertightness* is not necessarily the same as *waterproof*.

However, a *weathertight building*, even under severe weather conditions, is expected to limit moisture ingress to inconsequential amounts, insufficient to cause undue dampness inside *buildings* and damage to *building elements*. Moisture that may occasionally enter is able to harmlessly escape or evaporate.

**Wind zone** Categorisation of wind force experienced on a particular site as determined in NZS 3604, Section 5.

**COMMENT:**

Maximum ultimate limit state speeds are:

Low <i>wind zone</i>	=	wind speed of 32 m/s
Medium <i>wind zone</i>	=	wind speed of 37 m/s
High <i>wind zone</i>	=	wind speed of 44 m/s
Very high <i>wind zone</i>	=	wind speed of 50 m/s.

*Specific design* is required for wind speeds greater than 50 m/s.

Amend 13  
Nov 2023



# Verification Method G12/VM1

## 1.0 Water Supply Pipework Sizing

---

**1.0.1** The loading unit method of the Plumbing Engineering Services Design Guide is a means of establishing maximum simultaneous flow rates for use in sizing hot and cold *water supply systems* to comply with NZBC clause G12.

### COMMENT:

1. The application of the loading unit method referenced in this Verification Method to the sizing of hot and cold water services requires the application of specialist knowledge, experience and judgment.
2. The loading unit method referenced in this Verification Method is found in the distribution pipe sizing section of the Plumbing Engineering Services Design Guide, on pages 12-14 and Y-Axes of Graphs 3-4.
3. Graphs 3-4 are referenced solely for the purpose of converting Loading Units (on right side vertical Y-Axis) to corresponding Flow Rates (on left side vertical Y-Axis). The pipe dimensions and associated velocities shown in these graphs may not coincide with pipe Standards referenced in the Acceptable Solutions for complying with NZBC clause G12 (e.g. AS 1432 or NZS 3501 copper pipe).
4. Previous amendments to this Verification Method referenced earlier editions of AS/NZS 3500.1 and AS/NZS 3500.4. These standards are now referenced in G12/AS3.

Amend 13  
Nov 2023



# Acceptable Solution G12/AS1

## 1.0 Scope

**1.0.1** This Acceptable Solution applies to below ground and above ground piped *water supply systems*.

## 2.0 Materials

### 2.1 Water quality

**2.1.1** Components of the *water supply system* shall not contaminate *potable water*.

**2.1.2** Water supply materials and components shall comply with:

- a) BS 6920 if non-metallic, or
- b) AS/NZS 4020 if metallic or non-metallic.

### 2.1.3 Lead in plumbing products

From 1 September 2025, any product that contains copper alloy and is intended for use in contact with *potable water* for human consumption shall have a weighted average lead content of no more than 0.25% verified in the form of a test report provided by a test facility with IANZ or equivalent accreditation in accordance with NSF/ANSI/CAN 372.

#### COMMENT:

1. Some examples of products subject to Paragraph 2.1.3 include:

- a) Copper alloy fittings
- b) Stainless-steel braided hoses
- c) Valves (such as valves for isolation, backflow prevention, alteration of pressure and temperature)
- d) Taps and mixers
- e) Water meters
- f) Pumps (for use with cold and hot *water supply systems*)
- g) Water heaters
- h) Residential water filtration equipment
- i) Water dispensers (such as boiling and cooling units, drinking fountains and bottle fillers)
- j) Fire sprinkler systems connected to the cold water service that are not isolated from fixtures and fittings intended to supply water for human consumption

2. Some examples of products excluded by Paragraph 2.1.3 include:

- a) Showers and baths for bathing, including shower and bath mixers

- b) Emergency showers, eye wash and/or face wash equipment
  - c) Pumps used for irrigation, fire-fighting or other *non-potable water* purposes
  - d) Fire-fighting water services and equipment
  - e) Appliances, including washing machines and dishwashers
  - f) Commercial boilers associated with heating, ventilation and air-conditioning systems
  - g) *Sanitary fixtures* (such as toilets, cistern inlet valves, bidets, urinals)
  - h) *Non-potable water* systems (such as recycled water systems)
  - i) Products used exclusively for *non-potable* uses such as manufacturing, industrial processing, irrigation or any other uses where the water is not anticipated to be used for human consumption
3. Paragraph 2.1.3 does not prevent use of products certified in accordance with 2.1.3 prior to 1 September 2025.
4. Guidance on the identification of products that comply with Paragraph 2.1.3 is available from [www.building.govt.nz](http://www.building.govt.nz)

Amend 13  
Nov 2023

### 2.2 Pipe materials

**2.2.1** In addition to the requirements of Paragraph 2.1, pipe and pipe fitting materials shall comply with Table 1.

**2.2.2** All pipes and pipe fittings used for the piping of water shall be:

- a) Suitable for the temperatures and pressures within that system,
- b) Compatible with the water supply and environmental conditions in the particular location, and
- c) Where installed in an exposed situation, resistant to UV light.

Amend 13  
Nov 2023  
Amend 10  
Jan 2017

#### COMMENT:

Products for use in *water supply systems* that have been certified and marked in accordance with the requirements of the Australian WaterMark Certification Scheme and listed on the WaterMark Product Database may be deemed to meet the requirements of Paragraph 2.2 for their intended purpose.

**2.2.3** All copper alloy *water supply system* components in contact with water and subject to hydrostatic pressure shall be dezincification resistant (DR) and shall comply with AS 2345.

Amend 10  
Jan 2017

Amend 13  
Nov 2023

Amend 7  
Amend 9

Amend 13  
Nov 2023

Amend 10 & 13

**Table 1: Materials for Hot and Cold Water**  
Paragraphs 2.2.1 and 6.8.2

Material	Relevant Standard
<b>Hot and Cold</b>	
Copper	NZS 3501 AS 1432 for pipes (type A, B or C) AS 3688 for fittings
Polybutylene	AS/NZS 2642: Parts 1, 2 and 3
Cross-linked polyethylene (See Note)	AS/NZS 2492 for pipes AS/NZS 2537: Parts 1, 2, 3 and 4 for fittings
Stainless steel	AS 5200: Part 053 for pipes AS 3688 for fittings
<b>Cold Only</b>	
PVC-U	AS/NZS 1477 for pipes and fittings AS/NZS 3879 for PVC-U solvent cements and priming fluids
Polyethylene	AS/NZS 4130 for pipes AS/NZS 4129 for fittings
Note: Cross-linked polyethylene pipes used for hot water shall have a nominal pressure rating of PN16 or PN20.	

Amend 13  
Nov 2023

Amend 13  
Nov 2023

Amend 7  
Sep 2010

Amend 7  
Sep 2010

Amend 13  
Nov 2023

Amend 13  
Nov 2023

**3.0 Protection of Potable Water**

Amend 10  
Jan 2017

**3.1 Drawn water not to be returned**

**3.1.1** Water drawn from the *water main* shall be prevented from returning to that system by avoiding *cross connections* or *backflow*.

**3.2 Cross connections prohibited**

**3.2.1** The *water supply system* shall be installed so that there is no likelihood of *cross connection* between:

- a) A *potable water supply system* and a *non-potable water supply system*,
- b) A *potable water supply system* connected to a *water main*, and any water from another source including a private water supply,
- c) A *potable water supply system* and any bathing facilities including swimming, spa or paddling pools, and
- d) A *potable water supply system* and pipes, *fixtures* or equipment (including boilers and pumps) containing chemicals, liquids, gases or other *non-potable* substances.

Amend 10  
Jan 2017

**3.3 Cross Connection Hazard**

**3.3.1 High hazard**

Any condition, device or practice which, in connection with the *potable water supply system*, has the potential to cause death.

**COMMENT:**

High hazard may include but not necessarily be limited to:

- a) Autoclaves and sterilisers
- b) Systems containing chemicals such as anti-freeze, anti-corrosion, biocides, or fungicides
- c) Beauty salon and hairdresser’s sinks
- d) Boiler, chiller and cooling tower make-up water
- e) Car and factory washing facilities
- f) Chemical dispensers
- g) Chemical injectors
- h) Chlorinators
- i) Dental equipment
- j) Direct heat exchangers
- k) Fire sprinkler systems and fire hydrant systems that use toxic or hazardous water
- l) Hose taps associated with High hazard situations like mixing of pesticides and soil waste dump points
- m) Irrigation systems with chemicals
- n) Laboratories
- o) Mortuaries
- p) Pest control equipment
- q) Photography and X-ray machines
- r) Piers and docks
- s) Sewage pumps and sump ejectors
- t) Sluice sinks and bed pan washers
- u) Livestock water supply with added chemicals
- v) Veterinary equipment

Amend 13  
Nov 2023

Amend 13  
Nov 2023

- w) Bidets and douche seats
- x) Handheld bidet hoses and WC trigger sprays
- y) Connections for portable and mobile tankers
- z) Healthcare waste disposal equipment

**Note:** The examples given are not an exhaustive list. Where there is doubt comparison must be made to the hazard definitions.

### 3.3.2 Medium hazard

Any condition, device or practice which, in connection with the *potable water supply system*, has the potential to injure or endanger health.

**COMMENT:**

Medium hazard may include but not necessarily be limited to:

Amend 13  
Nov 2023

- a) Auxiliary water supplies such as pumped and non-pumped fire sprinkler secondary water
- b) Connections for appliances, vehicles or equipment
- c) Deionised water, reverse osmosis units and equipment cooling without chemicals
- d) Fire sprinkler systems and *building* hydrant systems
- e) Hose taps and fire hose reels associated with Medium hazard situations
- f) Irrigation systems with underground controllers
- g) Irrigation without chemicals
- h) Livestock water supply without added chemicals
- i) Untreated water storage tanks
- j) Water for steam cleaning
- k) Water for equipment cooling
- l) Drink dispensers with carbonators (see Note 2)
- m) Swimming pools, spas and fountains, other than those filled by a hose tap in conjunction with a *household unit*
- n) Treated grey water
- o) Air handling unit humidifiers without chemicals

Amend 13  
Nov 2023

Amend 13  
Nov 2023

**Notes:**

1. The examples given are not an exhaustive list. Where here is doubt comparison must be made to the hazard definitions.
2. For carbonated drink dispensers, the pipework material installed downstream of the *backflow prevention device* should not be made of copper and not be affected by carbon dioxide gas.

Amend 13  
Nov 2023

Amend 13  
Nov 2023

### 3.3.3 Low hazard

Any condition, device or practice which, in connection with the *potable water supply system*, would constitute a nuisance, by colour, odour or taste, but not injure or endanger health.

**COMMENT:**

Low hazard may include but not necessarily be limited to:

- a) Drink dispensers (except carbonators)
- b) Drinking fountains and bottle fillers
- c) Hose taps, other than those associated with Medium hazard or High hazard situations

Amend 13  
Nov 2023

**Note:** The examples given are not an exhaustive list. Where there is doubt comparison must be made to the hazard definitions.

### 3.4 Backflow protection

**3.4.1** *Backflow* protection shall be provided where it is possible for water or *contaminants* to *backflow* into the *potable water supply system*.

**COMMENT:**

The protection of non-*potable water* used for personal hygiene is contained in Paragraph 4.1.

**3.4.2** *Backflow* protection shall be determined by identifying the individual *cross connection* hazard(s) and *backflow* protection required. Water from each hazard shall be regarded as non-*potable* until an appropriate *backflow* protection is installed.

**3.4.3** *Backflow* protection shall be achieved by:

- a) An *air gap*, in accordance with Paragraph 3.5, or
- b) A *backflow prevention device* selected in accordance with Paragraphs 3.4.4 and 3.4.5.

**3.4.4** Backflow protection shall be appropriate to the *cross connection* hazard contained in Paragraph 3.3

**3.4.5** The selection of the appropriate *backflow* protection for the *cross connection* hazard is given in Table 2.

**COMMENT:**

1. Hose taps connected to the *potable water supply system* require *backflow* protection, and the minimum acceptable type of *backflow prevention device* is a permanently attached hose connection vacuum breaker.

For buildings other than *household units*, hose taps associated with Medium hazard or High hazard situations require appropriate *backflow* protection for the *cross-connection* hazard (see Table 2).

2. Table 2 includes air gap separation.

**3.4.6** All *backflow prevention devices* must be testable in service to verify effective performance.

**COMMENT:**

The testing of automatic *backflow prevention devices* is required for compliance with the Building Act 2004 as part of issuing a compliance schedule and annual building warrant of fitness. The compliance schedule will include the inspection, maintenance, and reporting procedures to be followed for each *backflow prevention device*.

**3.5 Containment backflow protection**

**3.5.1** Where *containment backflow protection* is not provided by the *network utility operator*, appropriate *containment backflow protection* shall be provided where a premises listed in Table 2A is served by a *water main*.

This paragraph does not apply to premises containing only *household units*. This paragraph also does not apply to the protection of *water main* connections used solely for firefighting purposes.

**COMMENT:**

1. *Containment backflow protection* is in addition to the provision of *backflow protection* for individual cross connection hazards.

2. *Containment backflow protection* is not required for compliance with this Acceptable Solution where an appropriate *backflow prevention device* is provided by the *network utility operator*.

3. *Containment backflow protection* for new *household units* is typically incorporated as part of the *network utility operators* water service connection.

**3.5.2** *Containment backflow protection* shall be achieved by providing an *air gap* or an appropriate *backflow prevention device* as near as practicable to the *network utility operators point of supply*.

**3.5.3** Water downstream of *containment backflow protection* shall be considered to be *potable*, unless there are unprotected *cross connection* hazards within the premises.

**3.5.4** *Containment backflow protection* shall be located:

- a) As near as practicable to the *network utility operators point of supply*, and
- b) With no branch connection between the *network utility operators point of supply* and the *containment backflow protection device*.

**3.6 Air gap**

**3.6.1** An *air gap* shall be an unobstructed distance between the lowest opening of a water supply outlet and the highest level of the overflow water. The *air gap* separation shall be the greater of 25 mm or twice the supply pipe *diameter*, as shown in Figure 1.

**3.6.2** To ensure the *air gap* distance is maintained the overflow pipe discharge flow rate shall be no less than the inlet pipe flow rate. Overflow pipes shall comply with Paragraph 5.2.2.

**COMMENT:**

AS/NZS 3500.1 Appendix F: Storage tanks – Inflow and overflow may be used to calculate the size of the overflow.

Amend 13  
Nov 2023

Amend 13  
Nov 2023

Amend 13  
Nov 2023

Amend 13  
Nov 2023

Amend 13  
Nov 2023

Amend 10  
Jan 2017

Amend 13  
Nov 2023



Type of backflow protection	CROSS CONNECTION HAZARD					
	HIGH		MEDIUM		LOW	
	back-pressure	back-siphonage	back-pressure	back-siphonage	back-pressure	back-siphonage
Air gap (see <b>Note 1</b> )	√	√	√	√	√	√
Reduced pressure zone device	√	√	√	√	√	√
Double check valve assembly (see <b>Note 2</b> )			√	√	√	√
Pressure type vacuum breaker (see <b>Note 3</b> )		√		√		√
Atmospheric type vacuum breaker		√		√		√
Hose connection vacuum breaker (see <b>Note 4</b> )						√
Notes:	1. Air gaps must not be installed in a toxic environment. 2. Double check valves can be installed in a medium and low hazard toxic environment. 3. Pressure type vacuum breakers are designed to vent at 7 kPa or less. However, they require a significantly higher pressure to reseal and must be installed only in systems which provide pressures sufficient to ensure full closing of the valve. 4. Hose connection vacuum breakers are designed to be under pressure only when water is being drawn from the water supply system and for short, intermittent periods of time.					

Amend 13  
Nov 2023

Amend 13  
Nov 2023

**Table 2A: Containment Backflow Protection**  
Paragraph 3.5.1

High Hazard Premises	Backflow Protection
Abattoirs	Air gap or Reduced pressure zone device
Vehicle and plant washing facilities	Air gap or Reduced pressure zone device
Chemical laboratories	Air gap or Reduced pressure zone device
Chemical plants	Air gap or Reduced pressure zone device
Commercial and industrial premises using, processing or manufacturing toxic chemicals	Air gap or Reduced pressure zone device
Hospitals, laboratories, dental surgeries, mortuaries and veterinary clinics	Air gap or Reduced pressure zone device
Petroleum processing plants, storage plants and service stations	Air gap or Reduced pressure zone device
Piers, docks, marinas and other waterfront facilities	Air gap or Reduced pressure zone device
Premises containing soil waste dump points, including stock truck effluent disposal sites	Air gap or Reduced pressure zone device
Sewage treatment plants and sewage lift stations	Air gap or Reduced pressure zone device
Tertiary and secondary education facilities with laboratories	Air gap or Reduced pressure zone device
Medium Hazard Premises	Backflow Protection
Caravan parks with no soil waste dump points	Air gap or Double check valve
Food and beverage processing plants	Air gap or Double check valve
Premises with fire-fighting water services	Air gap or Double check valve
Premises with an alternative water supply	Air gap or Double check valve
Public swimming pools	Air gap or Double check valve
Notes:	
1. The premises listed above are not an exhaustive list. Where there is doubt, <i>containment backflow protection</i> shall be selected to match highest <i>cross connection</i> hazard identified within the property by making comparison to the hazard descriptions in Paragraphs 3.3.1, 3.3.2 and 3.3.3.	
2. <i>Air gaps</i> must not be installed in a <i>toxic environment</i> .	
3. This table does not apply to premises contain only <i>household units</i> .	

Amend 13  
Nov 2023

Amend 13  
Nov 2023

**3.6.3** Air gaps and vacuum breakers shall not be used in a *toxic environment* where contaminated air could enter the water and piping system through the *air gap* or through the vacuum breakers air ports.

**3.6.4** Where any *fixture* or tank has more than one supply pipe, the *air gap* separation shall be the greater of 25 mm or twice the sum of the inlet pipe *diameters* and shall also comply with Paragraph 3.5.2.

**3.7 Backflow prevention devices**

Amend 13  
Nov 2023

**3.7.1 Location**

*Backflow prevention devices* and *air gaps* shall be located:

- a) As near as practicable to the potential source of contamination for *backflow prevention devices* that are not *containment backflow protection devices*, and
- b) In an accessible position for maintenance and testing to AS/NZS 2845.3 or the NZ backflow testing standard.

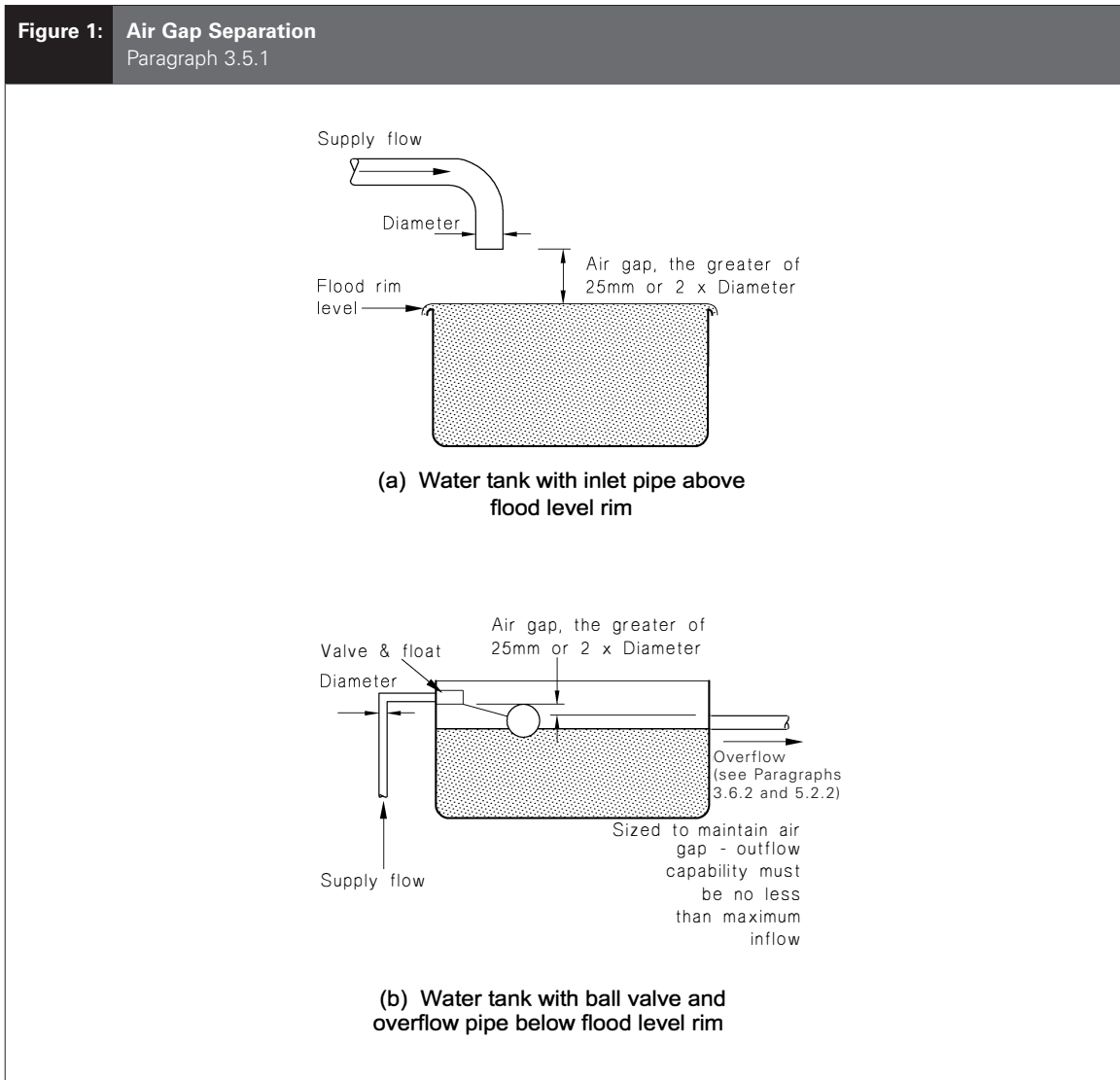
**COMMENT:**

An accessible position excludes those which necessitate the need to maintain or test a device from a ladder or scaffolding or enter into a confined space. Where a device is fitted with test taps, an accessible position includes sufficient clearance for the performance of the applicable test procedures.

Amend 8  
Oct 2011

Amend 13  
Nov 2023

**Figure 1: Air Gap Separation**  
Paragraph 3.5.1



Amend 13  
Nov 2023

### 3.7.2 Manufacture

*Backflow prevention devices* selected in accordance with Table 2 shall be manufactured in accordance with the relevant sections of AS/NZS 2845.1.

#### COMMENT:

See Figure 2 for example *backflow prevention device* schematics.

### 3.7.3 General installation requirements

*Backflow prevention devices* shall be:

- a) Attached only after the pipework has been flushed,
- b) Fitted with a line strainer immediately upstream to prevent particles and corrosion products from the pipework rendering the device ineffective,
- c) Fitted with connections which allow for the easy removal and replacement of the device.
- d) Fitted with isolation valves in accordance with Paragraph 3.8.1,
- e) Fitted without a by-pass, or with a by-pass that contains another *backflow prevention device* appropriate to the same hazard rating,
- f) Adequately supported,
- g) Installed without the application of heat, and
- h) Protected from:
  - i) the effects of corrosive or toxic environments,
  - ii) physical damage, and
  - iii) frost damage.

#### COMMENT:

1. Flanges or unions on the inlet and outlet sides of the device are examples of connections which allow for the easy removal or replacement of the device.
2. Corrosive environments may cause the malfunction of the device. Polluted air from a *toxic environment* may enter the piping system through the *air gap* or open vent port thus negating the effective *air gap* separation.
3. Where water splash is likely to occur during normal operation, maintenance or repair of a *backflow protection device* installed within a building, compliance with NZBC clause E3 Internal moisture will need to be demonstrated.

### 3.7.4 Specific installation requirements

*Backflow prevention devices* shall be installed as follows:

- a) Reduced pressure zone devices. These devices shall:
  - i) have free ventilation to the atmosphere for the relief valve outlet at all times,
  - ii) be located in an area that is not subject to ponding,

- iii) have the relief valve outlet located not less than 300 mm above the surrounding surface, and discharging in a visible position which does not present a hazard or create a risk of damage to any *building elements*,
- iv) be installed horizontally with the relief valve outlet facing vertically down, unless different orientations are specifically recommended by the device manufacturer, and
- v) be installed with adequate drainage provisions where installed within a building.

#### COMMENT:

Refer to valve manufacturer's information to determine relief valve discharge flow rates based on valve size and supply pressure.

- b) Double *check valve* devices. There are no additional requirements to those in Paragraph 3.6.3.
- c) Pressure type vacuum breakers. These devices shall:
  - i) be located not less than 300 mm above the highest outlet, measured from the highest outlet to the lowest part of the valve body,
  - ii) be installed vertically with the air ports at the top, and
  - iii) have free ventilation to the air ports at all times.
- d) Atmospheric vacuum breakers. These devices shall:
  - i) be located not less than 150 mm above the highest outlet, measured from the highest outlet to the lowest part of the valve body,
  - ii) have no valves located downstream of the vacuum breaker,
  - iii) under normal operation, not remain continuously pressurised for more than 12 hours,
  - iv) be installed vertically with the air ports at the top, and
  - v) have free ventilation to the air ports at all times.
- e) Hose connection vacuum breakers. These devices shall:
  - i) be attached to a hose connection in a manner that prevents them from being removed,
  - ii) have no valves located downstream of the vacuum breaker,
  - iii) under normal operation, not remain continuously pressurised with water for more than 12 hours, and
  - iv) have unrestricted air flow available to the air ports at all times.

Amend 13  
Nov 2023

Amend 13  
Nov 2023

Amend 10  
Jan 2017

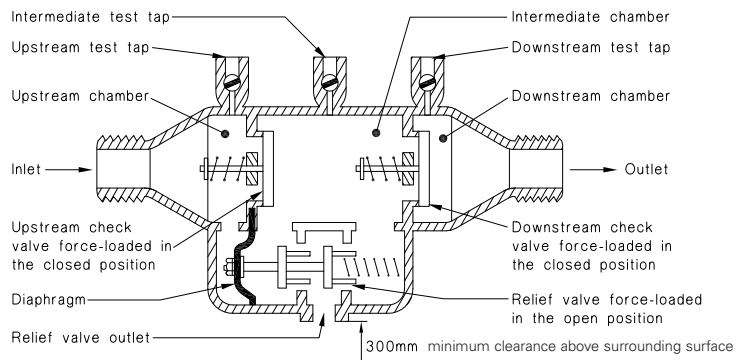
Amend 13  
Nov 2023

Amend 12  
Jun 2019

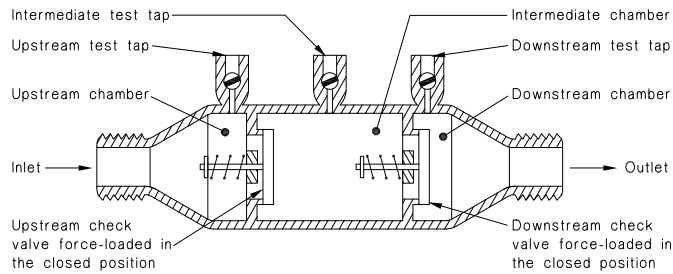
Amend 13  
Nov 2023

Amend 13  
Nov 2023

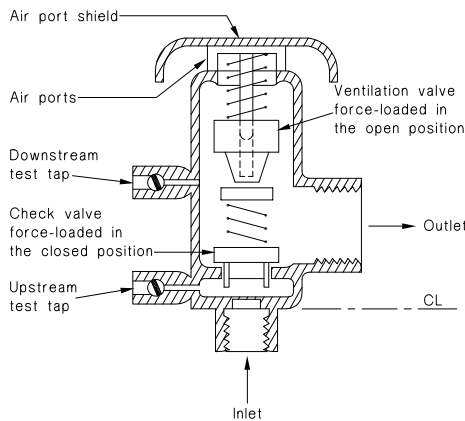
**Figure 2: Backflow Prevention Devices**  
Paragraph 3.6.2



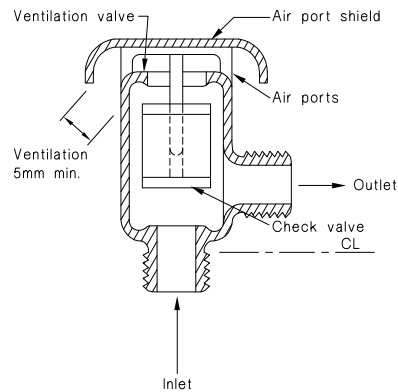
**(a) Schematic diagram of a reduced pressure zone device**



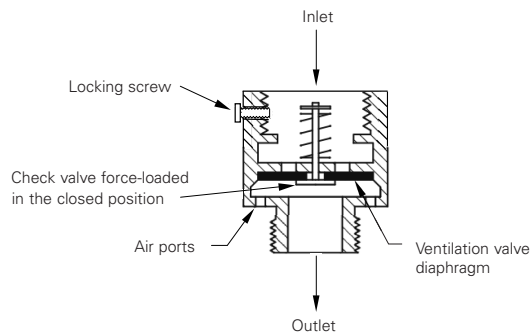
**(b) Schematic diagram of a double check valve**



**(c) Schematic diagram of a pressure type vacuum breaker**



**(d) Schematic diagram of an atmospheric vacuum breaker**



**(e) Schematic diagram of a hose connection vacuum breaker**

Amend 13  
Nov 2023

Amend 13  
Nov 2023

Amend 13  
Nov 2023

**3.8 Testing**

**3.8.1** Backflow protection installations shall have the following provisions to enable routine testing of their operational effectiveness:

- a) Resilient seated isolating valves shall be located immediately upstream and downstream of a reduced pressure zone device, double check valve assembly, or a pressure vacuum breaker,
- b) A resilient seated isolating valve shall be located immediately upstream of an atmospheric vacuum breaker, and

**COMMENT:**  
Full ported valves will provide the best flow characteristics.

- c) Reduced pressure zone devices, double check valve assemblies and pressure vacuum breakers shall have sufficient test points to enable testing of each check valve and relief valve.

**COMMENT:**  
Atmospheric vacuum breakers do not require test points.

Amend 5  
Feb 2004

Amend 13  
Nov 2023

**3.8.2** Reduced pressure zone devices, double check valves, pressure vacuum breakers and atmospheric vacuum breakers shall be tested and verified as meeting the test requirements of AS/NZS 2845.3 or the NZ backflow testing standard. Hose connection vacuum breakers shall be tested and verified as meeting the test requirements of the NZ backflow testing standard.

Amend 5  
Feb 2004  
Amend 8  
Oct 2011

**3.8.3** Backflow prevention devices shall be tested after installation or repair. Before testing the strainer shall be cleaned, the pipework flushed and the system commissioned.

Amend 5  
Feb 2004

**COMMENT:**  
Testing is also required annually in accordance with the compliance schedule for Specified System SS 7, except for devices installed in single residential dwellings.

Amend 10  
Jan 2017

**4.0 Non-potable Supply**

**4.1 Protection of non-potable water supplies**

**4.1.1** Where non-potable water supplies are used for personal hygiene they shall be protected from High and Medium hazards (see Paragraph 3.3). Where backflow protection is required it shall be in accordance with Paragraphs 3.1 to 3.8 of this Acceptable Solution.

Amend 5  
Feb 2004

**4.2 Outlet identification**

**4.2.1** NZBC F8 requires signs to be provided to all potential hazards. Outlets for non-potable water shall be identified non-potable, by displaying the safety sign shown in Figure 3.



**4.3 Pipeline identification**

**4.3.1** Where a non-potable water supply is reticulated around the building, all non-potable water supply pipework shall be Lilac coloured or made readily identifiable as non-potable water supply pipework using permanent identification markings in accordance with Paragraph 4.3.3.

Amend 13  
Nov 2023

**4.3.2** Where a non-potable water supply is reticulated around a building other than a household unit, the potable water supply pipework shall also be made readily identifiable as containing potable water in accordance with Paragraph 4.3.3.

**4.3.3** Where required by Paragraphs 4.3.1 and 4.3.2, permanent pipework identification markings shall be placed at spacings not exceeding 6 m, and adjacent to branches, junctions, valves, fixtures and wall/floor penetrations.

**4.3.4** All below ground non-potable water supply pipework shall be Lilac coloured or installed with underground marking tape laid 150 mm above the pipe which identifies the pipework below as containing non-potable water.

## 5.0 Water Supply

### 5.1 Water tanks

Amend 13  
Nov 2023

#### 5.1.1 Water storage

To ensure the health and safety of people in the event of the *water main* supply being interrupted, *buildings* having the classification of Community Care (e.g. hospitals, old people's homes, prisons) shall be provided with cold water storage of no less than 50 litres per person.

##### COMMENT:

1. Cold water storage is required only to maintain *adequate* personal hygiene within *buildings* where the principal users are legally or physically confined.
2. Community Care is a classified use defined in clause A1 of the Building Code.
3. *Network utility operators* cannot guarantee a continuous supply of water. *Building owners* may therefore wish to provide water storage to *buildings* having a classification other than Community Care, to enable continuation of a business, service, industrial process or other reason.
4. The "litres per person" is based on a daily use of 20 litres WC, 25 litres washing, 5 litres drinking.

Amend 13  
Nov 2023

### 5.2 Water tank installation

#### 5.2.1 Location

*Water tanks* in roof spaces shall be located and supported as detailed in Figure 4.

#### 5.2.2 Overflow pipes

*Water tanks* shall have an overflow pipe to discharge any overflow to a visible place within the same property that does not create a nuisance or damage to *building elements*. The overflow pipe shall be sized so that the discharge capacity is no less than the maximum inlet flow. The outlet of the overflow pipe shall not permit the entry of birds or vermin. Overflow from a WC cistern may discharge internally into a WC pan.

##### COMMENT:

- Acceptable *water tank* overflow pipe discharge locations may include:
- (a) into the safe tray, directly over the safe tray drain,
  - (b) directly into the safe tray drain pipe,
  - (c) onto an impervious graded floor that drains freely to a floor waste, or
  - (d) outside the *building*, clear of doors, windows or other openings.

Amend 13  
Nov 2023

### 5.2.3 Safe trays

Performance E3.3.2: states that; Free water from accidental overflow from *sanitary fixtures* or *sanitary appliances* must be disposed of in a way that avoids loss of *amenity* or damage to *household units* or *other property*. An acceptable method of preventing water damage is to locate a safe tray below the water tank (see Figure 4). The safe tray shall incorporate a drain with a minimum diameter of 40 mm. Where the tank overflow discharges into the safe tray, the diameter of the safe tray drain shall be greater than the overflow pipe from the tank and comply with Paragraph 5.2.2.

Amend 10  
Jan 2017

Amend 10  
Jan 2017

### 5.2.4 Covers

Covers shall be provided to:

- a) *Potable water tanks* to prevent contamination and the entry of vermin, and
- b) All tanks located in roof spaces to prevent condensation damaging *building elements*.

### 5.2.5 Access

Covers to *water tanks* shall be removable or shall contain a covered opening to allow access for inspection and maintenance. A minimum height clearance of 350 mm above the opening is necessary for easy access.

### 5.2.6 Supporting structure

The supporting structure for *water tanks* shall be protected from damage due to condensation where durability of the supports could be compromised by moisture. A material such as H3 treated timber shall be installed under the *water tank*.

### 5.2.7 Structural support

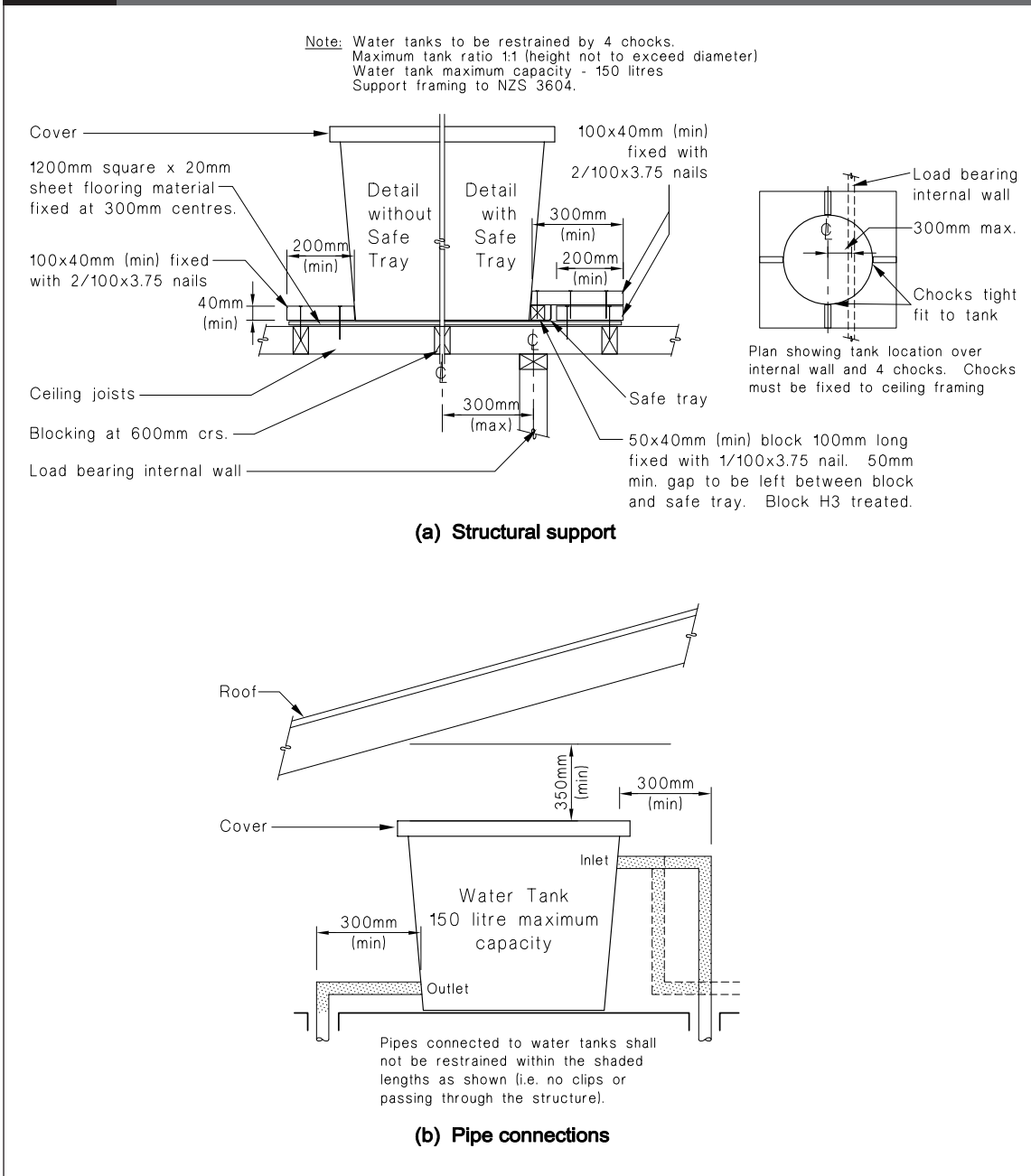
NZBC B1 requires *water tanks* to be adequately supported including seismic restraint. The method illustrated in Figure 4 is acceptable for *water tanks* up to 150 litre capacity and the maximum height to breadth ratio of 1:1.

### 5.2.8 Disinfection

*Potable water tanks* shall be cleaned and disinfected prior to use in accordance with AS/NZS 3500.1 Appendix G.

Amend 13  
Nov 2023

**Figure 4: Structural Support for Water Tanks (150 litre maximum capacity)**  
Paragraphs 5.2.1, 5.2.3 and 5.2.7



**5.3 Water pressures**

**5.3.1** The working pressure at any *sanitary fixture* or *sanitary appliance* shall be no less than 30 kPa (3 m head) and the static pressure shall be no more than 500 kPa (50 m head).

**COMMENT:**

Hose taps are outside the scope of Paragraph 5.3.1, as they are not *sanitary fixtures* or *sanitary appliances*.

**5.3.2** Where a pressure reducing or pressure limiting valve is installed, the available pressure head shall be taken as the outlet pressure of the valve plus or minus the pressure to the outlet or valve. Figure 5 illustrates how to determine available pressure head to the outlet or valve.

**5.3.3** Manufacturers' information shall be referred to for minimum and maximum pressure requirements for valves, tapware and other relevant *water supply system* components.

Amend 13  
Nov 2023

Amend 13  
Nov 2023



**5.4 Water pipe size**

**5.4.1 Pipe sizing**

Pipes shall be sized:

- a) To achieve the flow rates given in Table 3, or
- b) Using the sizes given in Table 4.

**COMMENT:**

Manufacturers' literature must be referred to for pressure and flow information on temperature control devices and tapware. Outlets (e.g. shower mixers and showerheads) must be appropriate for the available flow and pressure. Note the limitations on lengths and pipe sizes given in Table 4.

Amend 13  
Nov 2023

Amend 13  
Nov 2023

**Table 3: Acceptable Flow Rates to Sanitary Fixtures**  
Paragraph 5.4.1

Sanitary fixture	Flow rate and temperature l/s and °C	How measured
Bath	0.3 at 45°C	Mix hot and cold water to achieve 45°C
Sink	0.2 (hot) and 0.2 (cold)	Flow rates required at both hot and cold taps but not simultaneously
Laundry tub	0.2 (hot) and 0.2 (cold)	Flow rates required at both hot and cold taps but not simultaneously
Basin	0.1 at 45°C	Mix hot and cold water to achieve 45°C
Shower	0.1 at 42°C	Mix hot and cold water to achieve 42°C

**Notes:**

1. The flow rates required by this table shall be capable of being delivered simultaneously to the kitchen sink and one other fixture.
2. The temperatures in this table are to assist with ensuring acceptable flow rates are achieved when hot and cold water is mixed. Maximum safe water temperatures are given in Paragraph 6.14.1.

Amend 13  
Nov 2023

Amend 13  
Nov 2023

Amend 13  
Nov 2023

Amend 13  
Nov 2023

**Table 4: Tempering Valve or Thermostatic Mixing Valve and Nominal Pipe Diameters**  
Paragraphs 5.4.1 and 6.12.1

	Low pressure (i.e. header tank supply or low pressure)	Low pressure unvented (valve vented) and open vented	Mains pressure
Pressure of water at Tempering Valve or Thermostatic Mixing Valve (kPa)	20 – 30	30 – 120	over 300
Metres head (m)	2 – 3	>3 – 12	over 30
Minimum Tempering Valve or Thermostatic Mixing Valve size	25 mm	20 mm	15 mm
Pipes to Tempering Valve or Thermostatic Mixing Valve	25 mm (see <b>Note 3</b> )	20 mm	20 mm (15 mm optional)  (see <b>Note 1</b> )
Pipes to shower	20 mm	20 mm (see <b>Note 4</b> )	20 mm (see <b>Note 5</b> ) (15 mm optional) (see <b>Note 1</b> )
Pipes to sink/laundry (see <b>Note 2</b> )	20 mm	20 mm	15 mm
Pipes to bath (see <b>Note 2</b> )	20 mm	20 mm	15 mm
Pipes to basins (see <b>Note 2</b> )	15 mm	15 mm	10 mm

**Notes:**

1. If supplied by separate pipe from *storage water heater* to a single outlet.
2. This table is based on maximum pipe lengths of 20 metres.
3. 2 m maximum length from *water heater* outlet to tempering valve or thermostatic mixing valve
4. 15 mm if dedicated line to shower.
5. 10 mm if dedicated line to shower.
6. Pipe sizes in this table have been calculated to deliver water simultaneously to the kitchen sink and one other *fixture*.

Amend 5  
Feb 2004

Amend 13  
Nov 2023

Amend 13  
Nov 2023

Amend 13  
Nov 2023

Amend 13  
Nov 2023

Amend 13  
Nov 2023

Amend 13  
Nov 2023

Amend 13  
Nov 2023

**5.5 Maintenance facilities**

**5.5.1** The *water supply system* shall be provided with an isolating valve where a supply pipe enters the *building* or at each Dwelling unit within a Multi-unit dwelling.

**5.5.2** Where the water supply pipe serves a Detached dwelling, the isolating valve required by Paragraph 5.5.1 may be located at the property boundary.

Amend 13  
Nov 2023

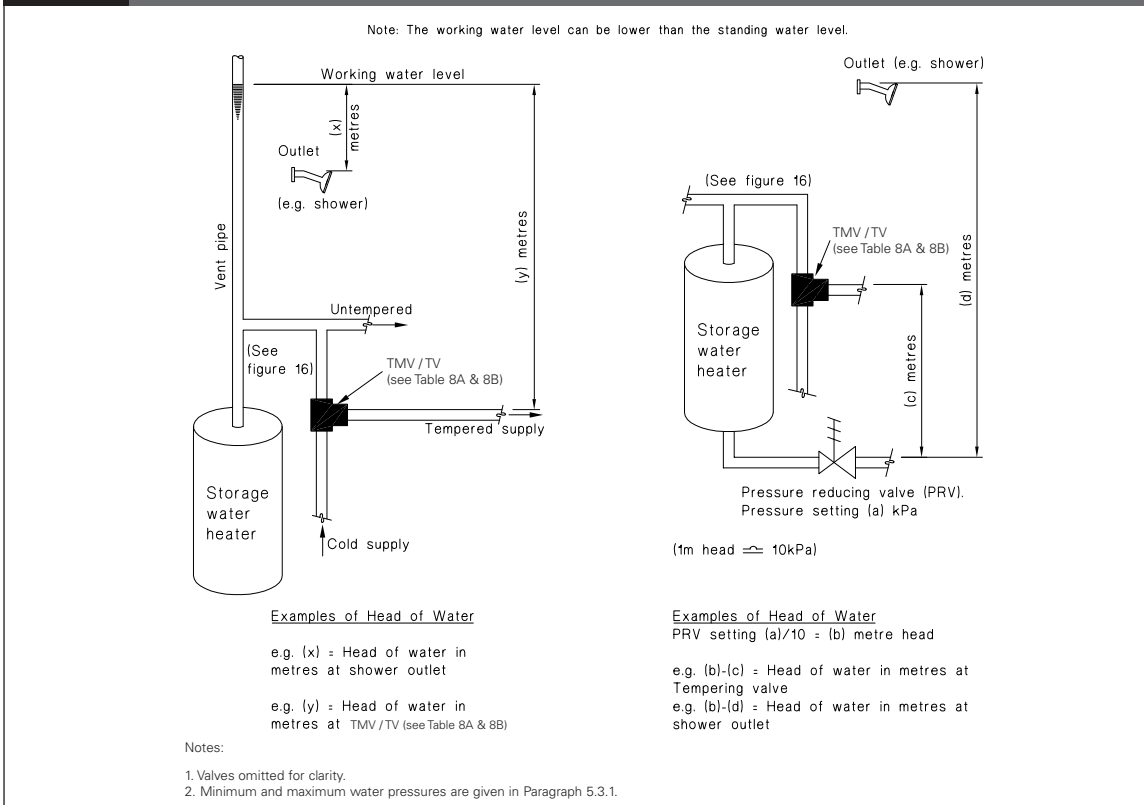
**COMMENT:**

Additional isolating valves may be provided for the maintenance of *storage water heaters*, valves and components.

**5.5.3** Provision shall be made for draining *storage water heaters* in accordance with Figure 7.

Amend 13  
Nov 2023

**Figure 5: Pressure head of water available**  
Paragraph 5.3.2



Amend 13  
Nov 2023

Amend 13  
Nov 2023

Amend 13  
Nov 2023

Amend 13  
Nov 2023

**6.0 Hot Water Supply System**

**6.1 Water heaters**

**6.1.1** *Water heaters* shall comply with Table 5.

**6.1.2** *Hot water supply systems* are given in Figures 6 to 11. (Note: Pipe insulation is not shown for clarity.)

**COMMENT:**

- Hot water flow and return circulating systems are outside the scope of this Acceptable Solution.
- An Acceptable Solution for the design and installation of hot water circulating systems can be found in AS/NZS 3500.4, which is referenced in G12/AS3.

Amend 13  
Nov 2023

**6.2 Water supply to storage water heaters**

**6.2.1** *Storage water heaters* shall be supplied with cold water at a pressure not exceeding their working pressure by means of a:

- Water tank*,
- Pressure reducing valve,
- Pressure limiting valve, or
- Mains pressure supply.

**6.2.2** *Storage water heaters* supplied by other than a *water tank* shall include a *non-return valve* as shown in Figures 7, 8(a), 8(b), 9 and 10 to prevent the *storage water heater* emptying and hot water flowing into the cold water supply and thence from the cold water taps.

Amend 13  
Nov 2023

Table 5: Water Heaters Paragraph 6.1.1		
Water heater type		Standard/Regulation
Electric low pressure copper storage water heater		NZS 4602
Electric storage water heater		NZS 4606: Parts 1, 2 and 3
Electric instantaneous water heater		AS/NZS 60335.2.35
Gas storage water heater		Gas (Safety and Measurement) Regulations
Gas instantaneous water heater		Gas (Safety and Measurement) Regulations
Solar storage water heater		NZS 4613 (see G12/AS2)
		AS/NZS 2712 (see G12/AS2)

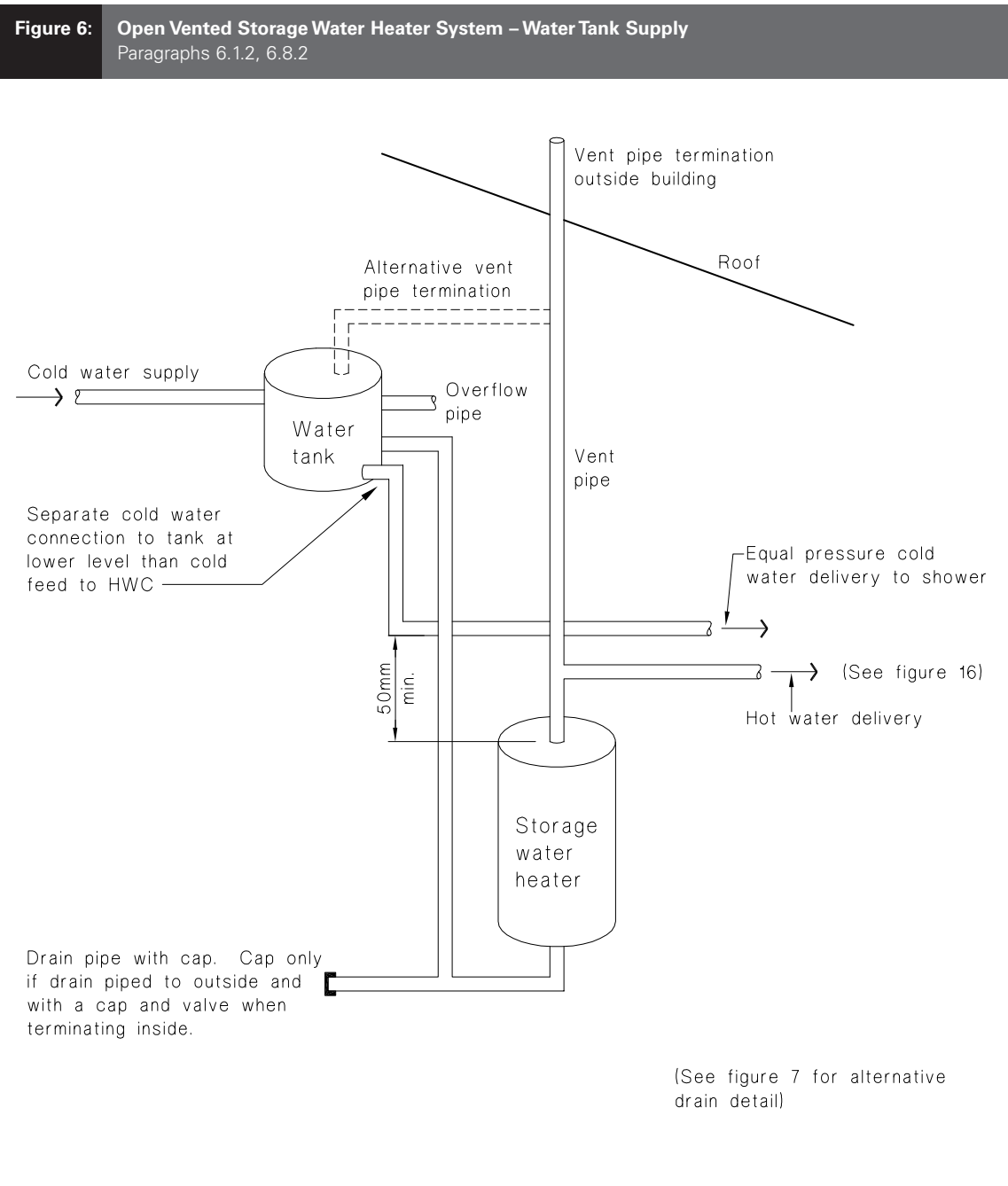
Amend 5  
Feb 2004

Amend 7  
Sep 2010

Amend 7  
Sep 2010

Amend 9  
Feb 2014

Amend 13  
Nov 2023  
Third Edition  
Dec 2007



Amend 5  
Feb 2004

**6.2.3** Filters or strainers shall be installed upstream of any valves that could be damaged or malfunction due to solids in the water supply.

**6.3 Operating devices**

**6.3.1** Electric and gas storage water heaters shall have their temperature controlled by a thermostat on each heating unit.

**6.3.2** Open vented storage water heaters shall have a vent pipe complying with Paragraph 6.8.

**6.3.3** Valve vented (unvented) systems shall have:

- a) Relief from the expansion of hot water by either:
  - i) an expansion control valve (low pressure valve vented and mains pressure systems), or
  - ii) an expansion vessel (mains pressure systems only),
- b) A vacuum relief valve to prevent collapse of the storage water heater where it is not designed to withstand a full vacuum, and
- c) Valves complying with Table 6.

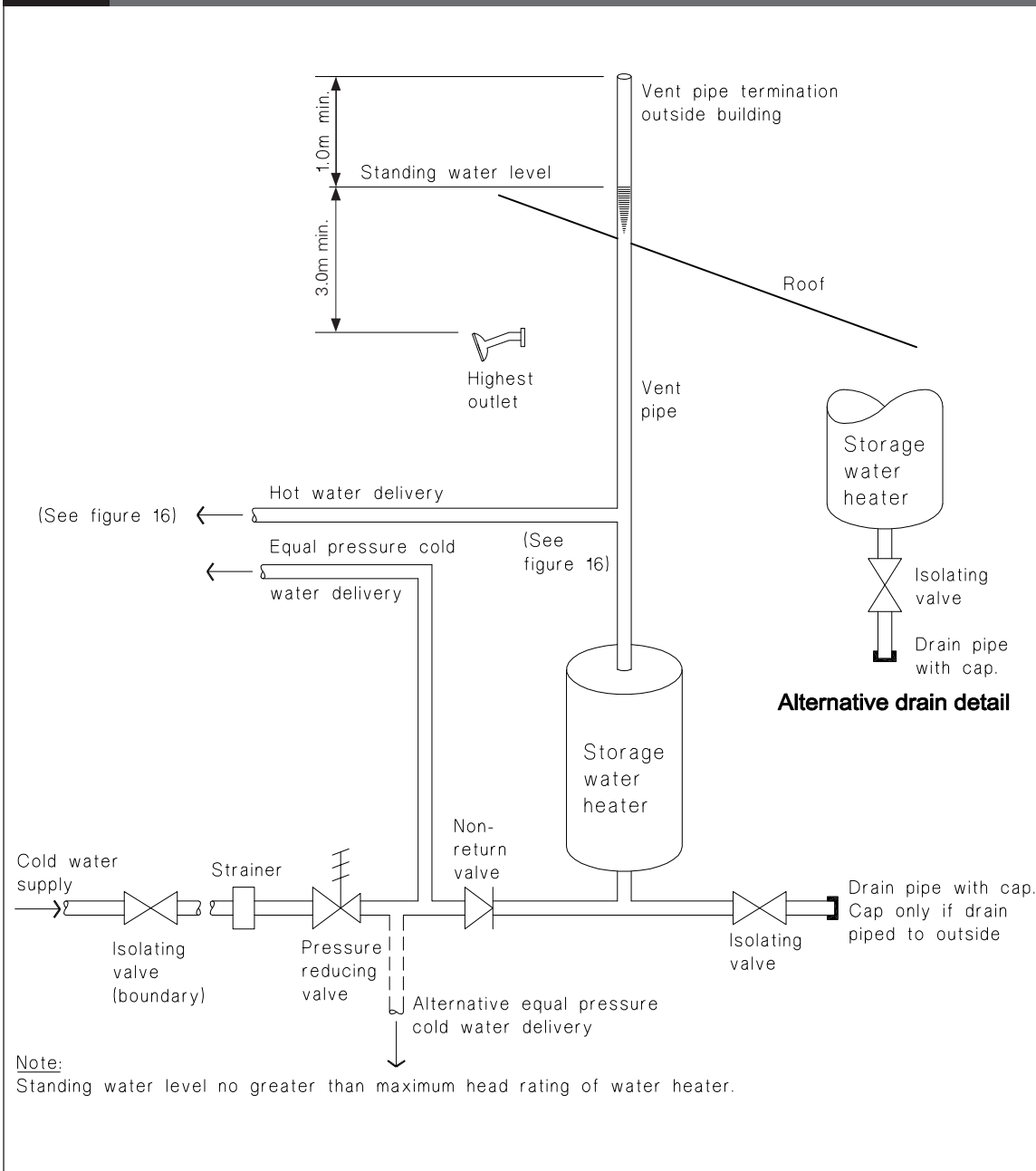
Amend 13  
Nov 2023

Amend 5  
Feb 2004

**Figure 7: Open Vented Storage Water Heater System – Pressure Reducing Valve**  
Paragraphs 5.5.3, 6.1.2, 6.2.1 b), 6.8.2 d)

Amend 13  
Nov 2023

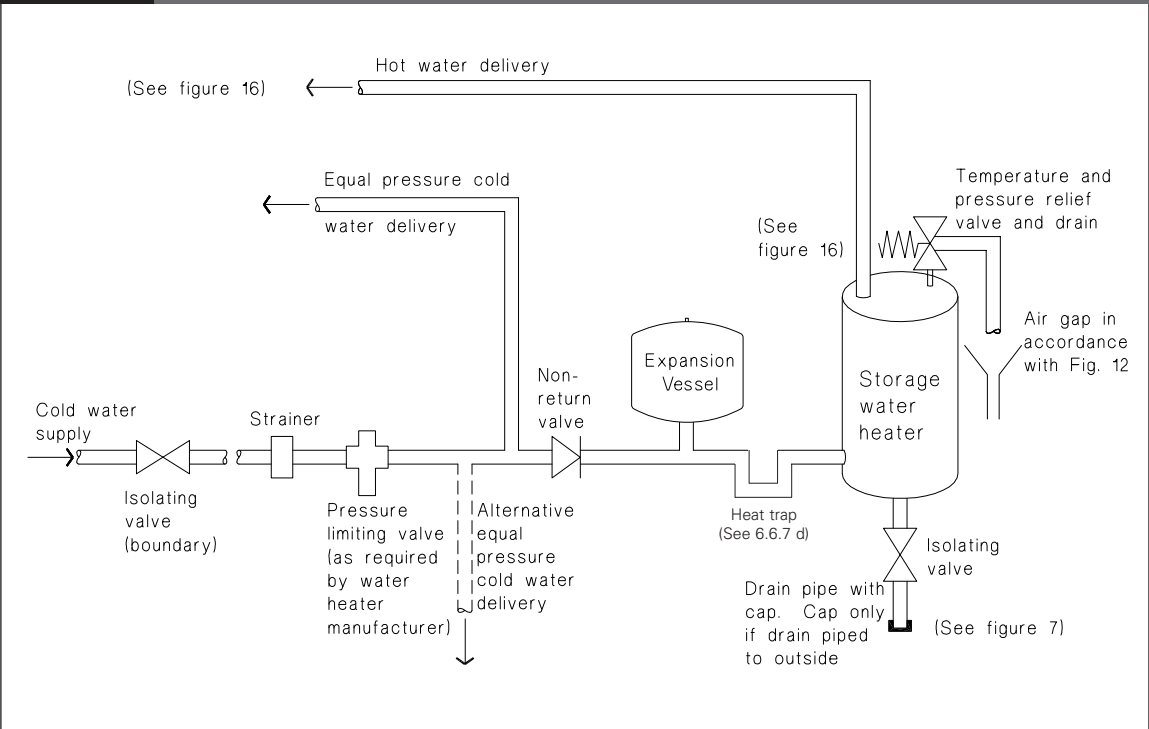
Amend 5  
Feb 2004



Amend 13  
Nov 2023

Amend 13  
Nov 2023

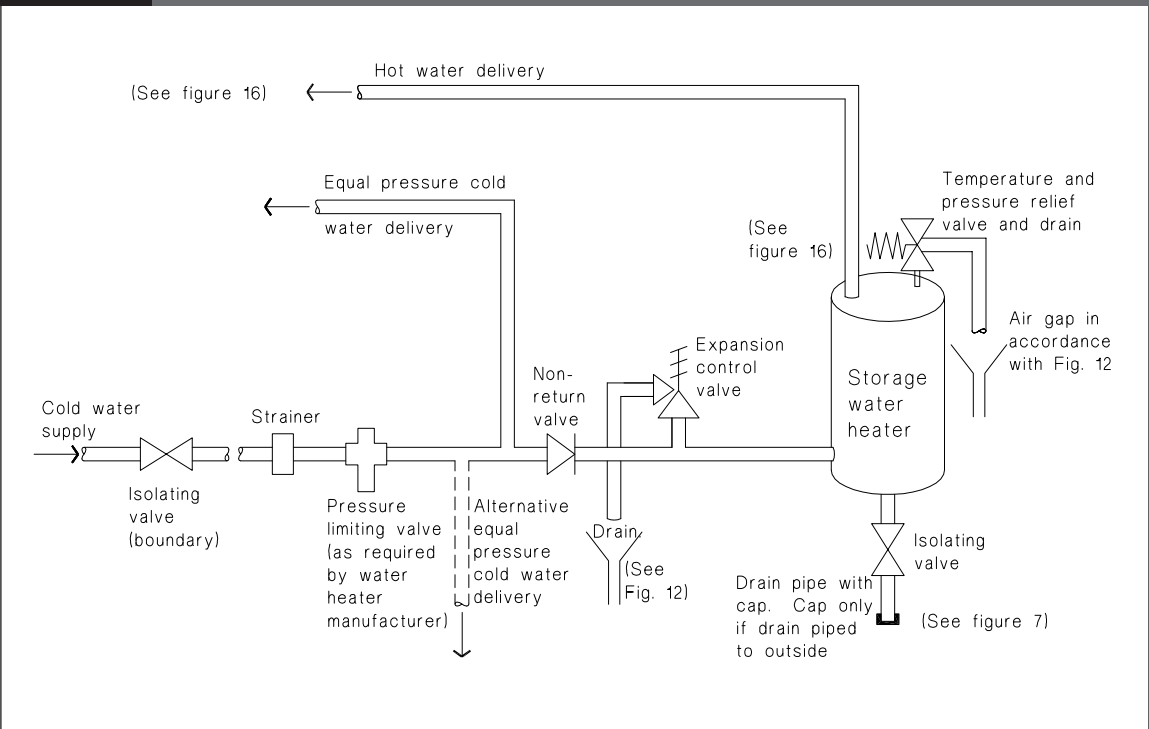
**Figure 8(a): Mains Pressure Storage Water Heater System (unvented) - Expansion Vessel**  
Paragraphs 6.1.2 and 6.2.1 c)



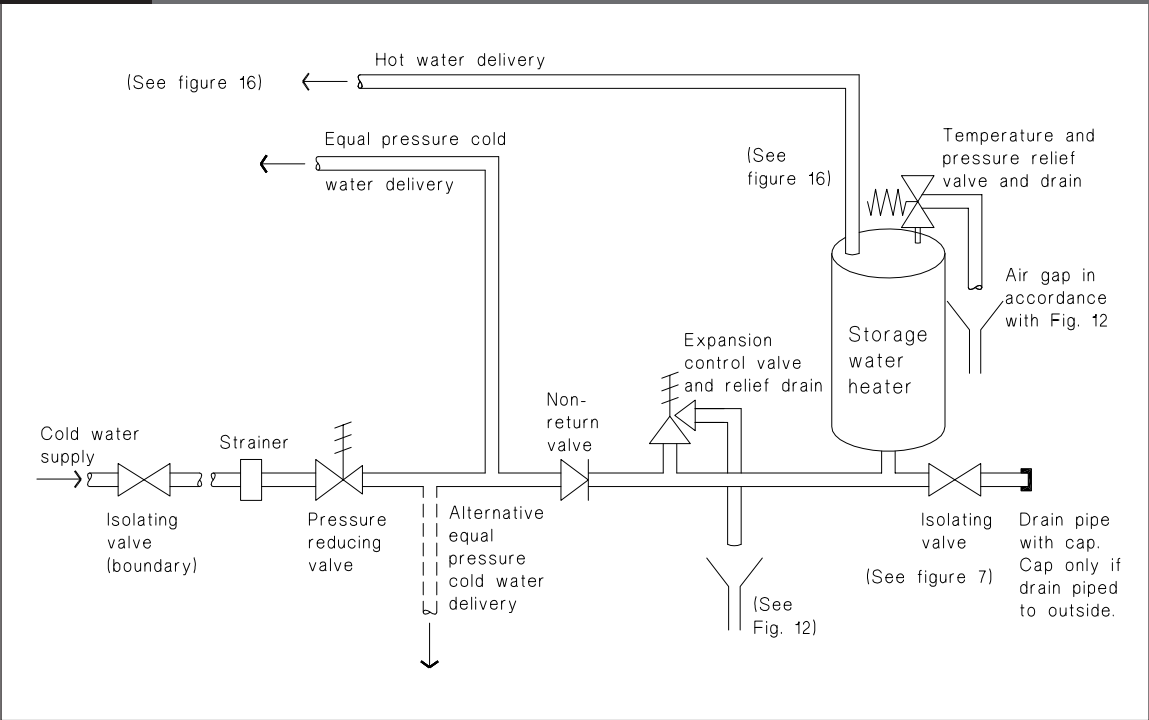
Amend 13  
Nov 2023

Amend 13  
Nov 2023

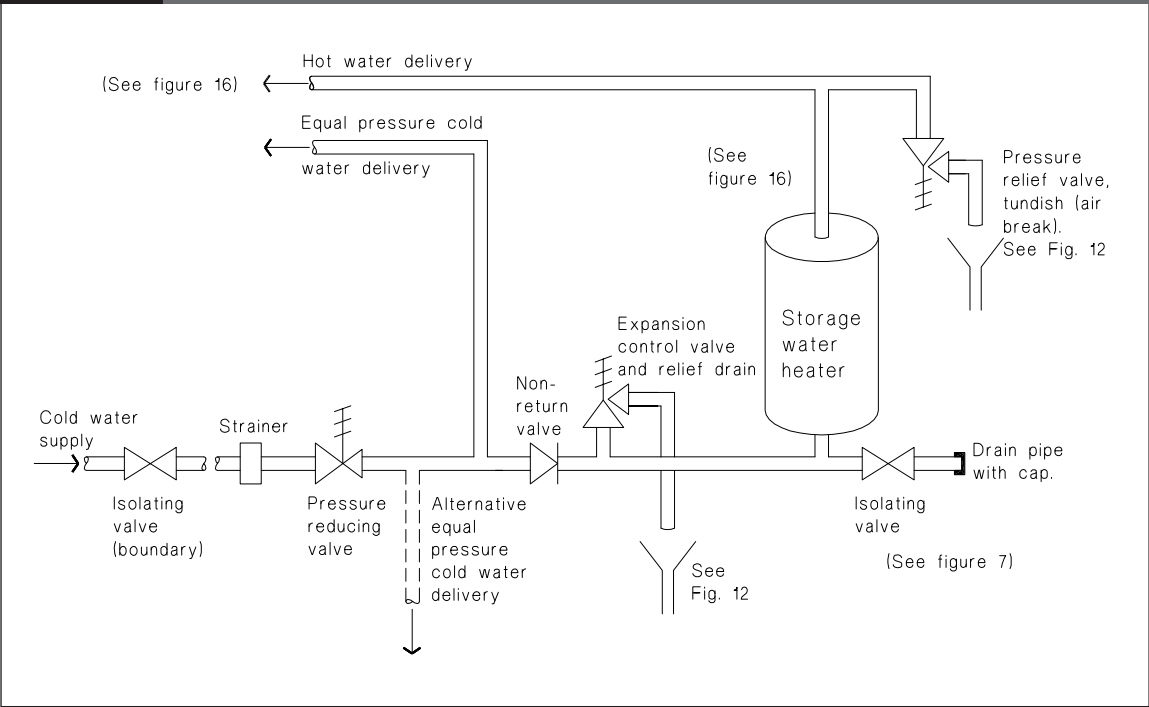
**Figure 8(b): Mains Pressure Storage Water Heater System (unvented) - Expansion Control Valve**  
Paragraphs 6.1.2 and 6.2.1 c)

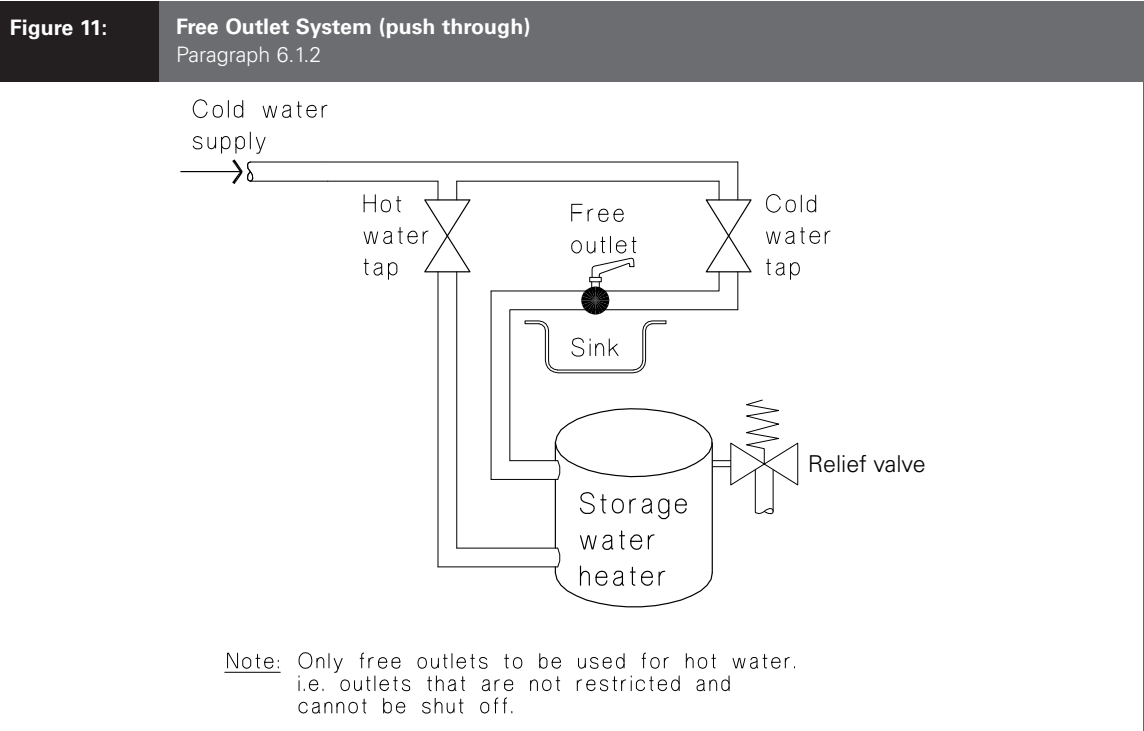


**Figure 9:** Low Pressure Valve – Vented Water Heater System – Temperature and Pressure Relief Valve  
Paragraphs 6.1.2 and 6.2.1 b)



**Figure 10:** Low Pressure Valve – Vented Storage Water Heater System – Pressure Relief Valve  
Paragraphs 6.1.2 and 6.2.1 b)





Amend 13  
Nov 2023

**6.4 Safety devices**

**6.4.1** Valve vented (unvented) systems shall have in addition to Paragraph 6.3.3 the following safety devices:

- a) Combined temperature/pressure relief valve for systems with a working pressure greater than 120 kPa,
- b) Combined temperature/pressure relief valve or a pressure relief valve for systems with a working pressure less than 120 kPa,
- c) An energy cut-off for each heating unit on gas and electric systems, and
- d) Valves complying with Table 6.

**6.4.2** *Free outlet (push through) water heaters* shall have a relief valve. No relief valve drain is required.

**6.5 Temperature control devices**

**6.5.1** Electric thermostats and energy cut-off devices shall comply with NZS 6214 or AS 1308.

**6.5.2** Energy cut-off devices shall be designed to:

- a) Be reset manually, and
- b) Disconnect the energy supply before the water temperature exceeds 95°C.

**6.6 Relief valves and expansion vessels**

**6.6.1** All valves and expansion vessels shall have flow rates, pressure and *diameter* compatible with the system they serve.

**6.6.2** Pressure relief valves and expansion control valves shall have:

- a) A flow rate capacity of no less than the rate of cold water supply, and

- b) A maximum pressure rating of no more than the working pressure of the hot water storage vessel.

**6.6.3** Expansion control valves shall have a pressure rating of no less than that of the water supply pressure to the *storage water heater*, but less than the pressure rating of the pressure relief valve.

**6.6.4** The following valves shall have an energy rating greater than that of the energy sources heating the water:

- a) Temperature/pressure relief valve, and
- b) Pressure relief valve.

**6.6.5 Valve installation**

- a) Temperature/pressure relief valves shall be located with their probe within the top 20% of the water capacity and no more than 150 mm from the top of the container,
- b) Pressure relief valves shall be located no further than 1 metre from the *storage water heater*, and
- c) Valves shall be installed in a manner which provides for easy access for replacement, servicing or maintenance of devices.

Amend 13  
Nov 2023

Amend 13  
Nov 2023

Amend 5  
Feb 2004

**Table 6: Storage Water Heater Valves**  
Paragraph 6.3.3 c) and 6.4.1 d)

Valve type	Standard
Cold water expansion valves	NZS 4608 BS EN 1491 AS 1357: Part 1
Temperature/pressure relief valve	NZS 4608 BS EN 1490 AS 1357: Part 1
Non-return valves	NZS 4608 AS 1357: Part 1
Vacuum relief valves	NZS 4608 AS 1357: Part 2
Pressure reducing valves and pressure limiting valves	NZS 4608 BS EN 1567 AS 1357: Part 2
Pressure relief valves	NZS 4608

Amend 5  
Feb 2004

Amend 10  
Jan 2017

Third Edition  
Dec 2007

Amend 13  
Nov 2023

Amend 5  
Feb 2004

Amend 7  
Sep 2010

Amend 7  
Sep 2010



Amend 5  
Feb 2004

Amend 13  
Nov 2023

**6.6.6** There shall be no valve or restriction between the relief valve and the *storage water heater*.

**6.6.7 Expansion Vessels**

Where an expansion vessel is provided to manage the effects of thermal expansion in a mains pressure *storage water heater* system, the expansion vessel shall:

- a) Comply with BS EN 13831 and be suitable for use with potable water in accordance with the provisions of Paragraph 2.0,
- b) Be sized to ensure that the maximum system pressure does not exceed the working pressure of the hot water storage vessel and the working pressure of expansion vessel itself,
- c) Be pre-charged to a pressure matching the water supply pressure to the mains pressure *storage water heater*,
- d) Be installed with a heat trap on the cold water supply pipe between the expansion vessel and the storage water heater when

the expansion vessel is located within 500 mm of a storage water heater inlet.

- e) Be installed in a manner which provides for easy access for replacement, servicing and maintenance, and
- f) Be adequately supported or restrained to prevent damage at the point of connection of the vessel to the pipework if the vessel is subject to external forces.

**6.6.8 Expansion Vessel Sizing**

The minimum capacity of an expansion vessel shall be calculated from the formula:

$$V_e = V_s \times \eta / AF$$

Where

$V_e$  = minimum capacity of expansion vessel (litre)

$V_s$  = volume of hot water storage (litre)

$\eta$  = expansion factor (from Table 7)

$AF = (P_2 - P_1) / (P_2 + 101)$

$P_1$  = water supply pressure (kPa, typically the setting of the pressure limiting or pressure reducing valve)

$P_2 = 0.85 \times \text{TPR valve setting (kPa)}$

<b>Table 7: Expansion Factors (Water supplied at 0° to 20°C)</b> Paragraph 6.6.8								
$T_{hot}^*$	60	65	70	75	80	85	90	95
$\eta$	0.017	0.019	0.022	0.025	0.028	0.031	0.035	0.038

\* $T_{hot}$  = Storage water heater thermostat setting (°C)

**COMMENT:**

<b><math>V_e</math> Minimum Expansion Vessel Capacity (litre)</b>								
<b><math>T_{hot}</math> Storage water heater thermostat setting (°C)</b>								
<b><math>V_s</math> (litre)</b>	<b>60</b>	<b>65</b>	<b>70</b>	<b>75</b>	<b>80</b>	<b>85</b>	<b>90</b>	<b>95</b>
<b>135</b>	8	9	11	12	14	15	17	19
<b>180</b>	11	13	15	17	19	21	23	25
<b>250</b>	16	18	20	23	26	29	32	35
<b>300</b>	19	21	24	28	31	34	39	42

Note:

The minimum expansion vessel capacities shown in this table are based on a mains *pressure storage water heater system* with a 500 kPa water supply pressure and an 850 kPa TPR valve setting.

1. The table above provides examples of minimum expansion vessel capacities for a mains *pressure storage water heater system* calculated using this method, for a situation in which:

$P_1 = 500$  kPa ( $P_1$  = Pressure limiting valve setting)

$P_2 = 722.5$  kPa ( $P_2 = 0.85 \times$  TPR valve setting)

2. Depending on the vessel design its capacity (maximum acceptance volume) may be less than its total volume.

3. AS/NZS 3500.4 contains another method for calculating the size of expansion vessels, and is referenced in G12/AS3.

## 6.7 Relief valve drains

**6.7.1** Relief valve drains (see Figures 12 and 13) shall be fitted to:

- a) Temperature/pressure relief valves,
- b) Pressure relief valves, and
- c) Expansion control valves.

**6.7.2** Relief valve drains shall:

- a) Be of copper pipe,
- b) Have no restrictions or valves,
- c) Have a continuous fall from the relief valve to the outlet,
- d) Discharge in a visible position which does not present a hazard or damage to other *building elements* (except when used in association with *free outlet storage water heaters*),

**COMMENT:**

For example, discharging via an air break into an external gully trap, or via an air break into a tundish within a cupboard.

- e) Have a minimum *diameter* of the same size as the valve outlet,
- f) Have the number of changes in direction plus the length of the relief drain (in metres) not exceeding 12,

**COMMENT:**

For example: 7 metres of pipe allows the total number of bends to be 5.

- g) Be connected to a relief valve in accordance with the valve manufacturer's specification,
- h) Comply with Paragraph 6.7.3 when relief valve drains are combined, and
- i) Comply with Paragraphs 6.7.4 and 6.7.5 when freezing is likely.

## 6.7.3 Combined relief valve drains

When relief valve drains are combined the combined drain shall (see Figure 13):

- a) Receive discharges from one temperature/pressure relief valve or the pressure relief valve and one expansion control valve,
- b) Discharge via a minimum air break of 25 mm, and
- c) Have a minimum size of 20 mm *diameter* and be one size larger than the largest relief valve outlet.

**COMMENT:**

The drain from the *storage water heater* may also be connected into the combined relief valve drain.

## 6.7.4 Water heaters located where freezing is likely

Additional requirements for relief valve drains are (see Figure 12):

- a) Relieve one valve only, and
- b) Comply with Paragraph 6.7.5 when freezing of the drain is likely.

**COMMENT:**

This paragraph applies to *water heaters* that are installed outside the *building's* thermal envelope in cold climates.

## 6.7.5 Relief drains located where freezing is likely

Additional requirements for relief drains located where freezing is likely (see Figure 12) are that:

- a) Relief valve drain pipes shall discharge over a tundish with a 25 mm air break before the drain pipe enters a zone where freezing is likely, and
- b) Relief valve drains from a tundish shall be one size larger than the outlet *diameter* of the relief valve.

**COMMENT:**

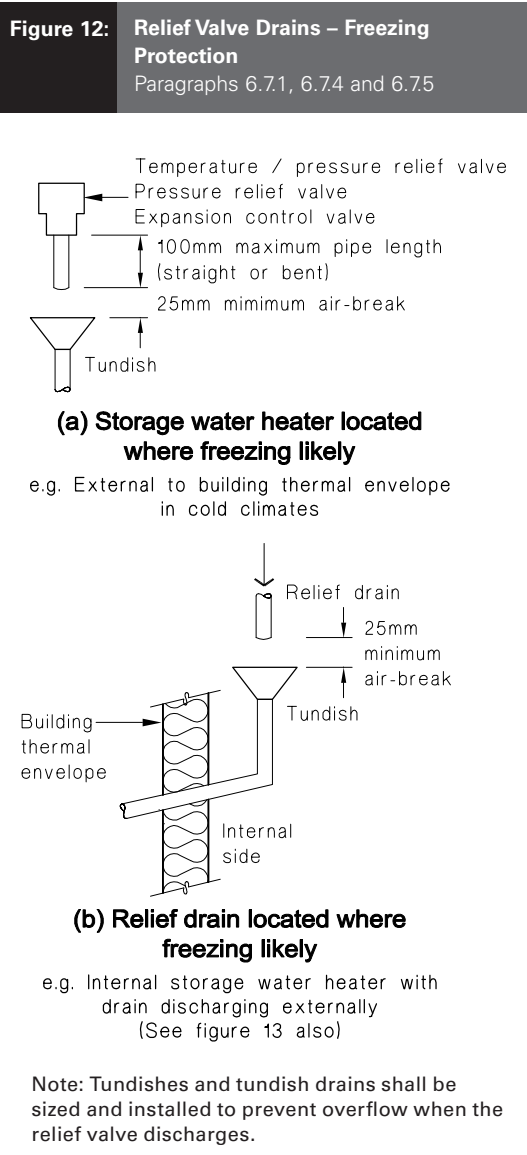
This paragraph applies to *storage water heaters* located inside the *building's* thermal envelope with relief valve drains discharging where freezing of the drain is likely.

Amend 13  
Nov 2023

Amend 5  
Feb 2004

Amend 5  
Feb 2004

Amend 5  
Feb 2004



Amend 13  
Nov 2023

Amend 5  
Feb 2004

**6.7.6** Closed cell foam polymer insulation or fibre glass insulation which is preformed to the shape of the pipe and not less than 13 mm thick, is acceptable material for preventing pipes less than or equal to 40 mm diameter from freezing.

Amend 13  
Nov 2023

**6.7.7** Any insulation material that absorbs moisture shall be protected in a waterproof membrane. Any insulation material exposed to direct sunlight shall be UV resistant or suitably protected to withstand the degradation that can be caused by exposure to ultraviolet light.

Amend 13  
Nov 2023

## 6.8 Vent pipes

Amend 5  
Feb 2004

**6.8.1** Vent pipes for open vented storage water heaters shall comply with the provisions of Paragraphs 6.8.2 and 6.8.3.

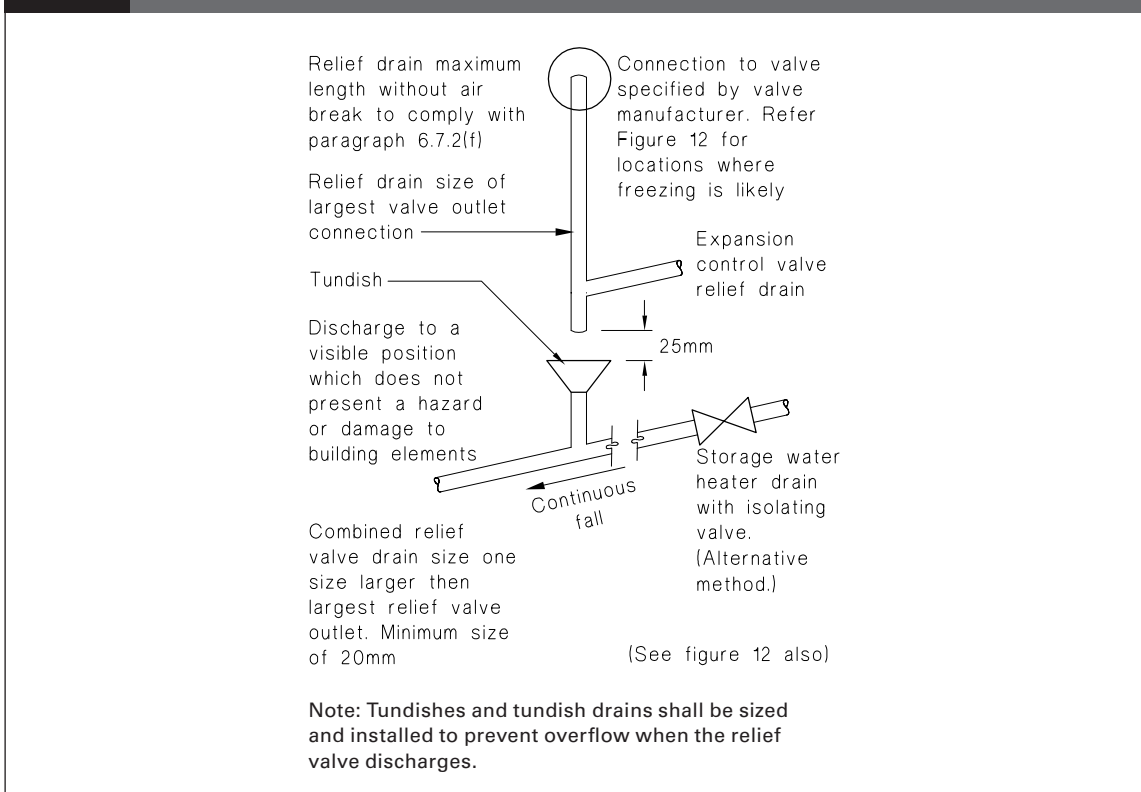
### 6.8.2 Installation

- Materials: The pipe material shall be copper complying with Table 1,
- Diameter: The diameter of the vent pipe shall be no less than that of the hot water outlet fitting on the storage water heater and no less than 20 mm where the energy input rating is greater than 3 Kw,
- Termination: The vent pipe (see Figure 6) shall terminate either:
  - outside the building, or
  - over a water tank supplying the storage water heater, and
- Height: The vent pipe height, measured in metres from the base of the storage water heater, shall not exceed the height (in metres) that equates to the maximum pressure rating of the storage water heater, and
- Water level: The normal standing water level in the vent pipe shall be a minimum of 3.0 metres above the highest outlet. The height of the vent pipe shall be:
  - 300 mm above the standing water level of the vent pipe, for tank fed systems, and
  - 1.0 m above the standing water level, for pressure reducing valve fed systems.

#### COMMENT:

- The 1.0 m height has been found to prevent hot water loss due to the pressure reducing valve creeping.
- The 3.0 m height is measured from the highest fitting in order to ensure sufficient working head to that fitting.
- 9.81 kPa = 1 metre in head = 1 metre in height.

**Figure 13: Relief Valve Drains – Combined**  
Paragraphs 6.7.1, 6.7.2 f) and 6.7.3



Amend 5  
Feb 2004

Amend 13  
Nov 2023

**6.8.3 Insulation**

- a) Where the *vent pipe* is likely to be subjected to freezing, it shall be insulated between the top of the *storage water heater*, and a point no less than 300 mm above the normal standing water level in the *vent pipe*.
- b) Insulation material is to comply with Paragraphs 6.7.6 and 6.7.7.

Amend 13  
Nov 2023

**6.9 Another acceptable solution for the installation of open vented storage water heaters**

**6.9.1** NZS 4603 is an acceptable solution for open vented low pressure *storage water heaters*, but may exceed the performance criteria of NZBC G12.

**6.10 Another acceptable solution for the installation of unvented (valve vented) storage water heaters.**

**6.10.1** NZS 4607 is an acceptable solution for unvented (valve vented) *storage water heaters*, but may exceed the performance criteria of NZBC G12.

Third Edition  
Dec 2007

Third Edition  
Dec 2007

Amend 5  
Feb 2004

**6.11 Water heater installation**

**6.11.1** *Water heaters* shall be installed in accordance with the manufacturer's instructions.

**6.11.2** Where heating units, sacrificial anodes, thermostats, pipework connections, valves, or other accessories being components of a *storage water heater* are installed, they shall be accessible for inspection, maintenance and removal.

**6.11.3** *Storage water heaters* shall have:

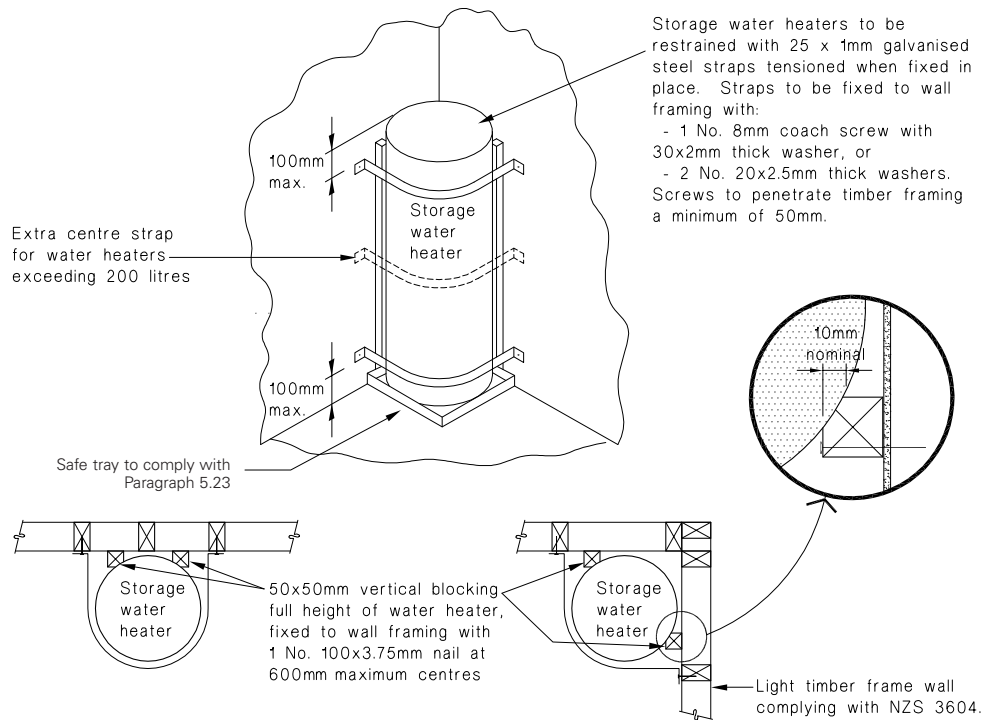
- a) Safe trays complying with Paragraph 5.2.3
- b) Connections compatible with the pipe material used, and
- c) Drain pipes (for every *storage water heater* of more than 45 litres capacity) which:
  - i) have a conveniently located isolating valve, and terminate with a cap or plug suitably located to easily empty the vessel for maintenance, or
  - ii) terminate outside the *building* with a cap only.

Amend 10  
Jan 2017

Amend 5  
Feb 2004

Amend 5  
Feb 2004

**Figure 14: Seismic Restraint of Storage Water Heaters 90 – 360 litres**  
Paragraph 6.11.4



Storage water heaters to be restrained with 25 x 1mm galvanised steel straps tensioned when fixed in place. Straps to be fixed to wall framing with:  
- 1 No. 8mm coach screw with 30x2mm thick washer, or  
- 2 No. 20x2.5mm thick washers.  
Screws to penetrate timber framing a minimum of 50mm.

**Notes:**

1. An additional centre strap is required where a *storage water heater* is located more than 12 m above finished ground level.
2. Additional timber framing may be required in retrofit situations to ensure adequate strap fixing is available.
3. Straps shall not be installed where they clash with water heater inlets, outlets or controls.
4. Where the 100 mm maximum strap distance from the top or bottom of the *storage water heater* cannot be achieved, straps may be placed within the top and bottom 25% with one additional strap placed centrally for water heaters < 200 litres, and two additional evenly spaced straps for water heaters 200 - 360 litres.
5. A maximum total of four straps are required when complying with both Note 1 and Note 4.

Amend 13  
Nov 2023

Amend 5  
Feb 2004

**6.11.4 Structural Support**

NZBC B1.3.2 requires *building elements* (including *storage water heaters*) to be adequately supported including support against earthquake forces. The method illustrated in Figure 14 is acceptable for *water heaters* up to 360 litre capacity. Where fittings and pipework are attached to the *water heater* through the supporting platform or floor a 50 mm minimum clearance shall be provided between the fitting and the support structure.

Amend 13  
Nov 2023

**6.12 Hot water pipe sizes**

**6.12.1** The *diameter* of hot water supply pipes from *storage water heaters* and to *sanitary fixtures* shall be no less than those required by Table 4.

**6.13 Wet-back water heaters**

**6.13.1** Wet-back water heating systems shall be:

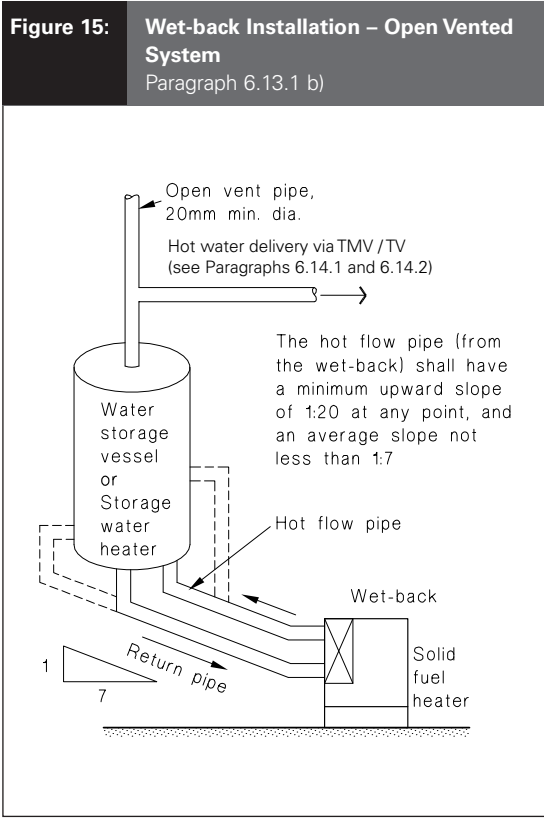
- a) Designed and installed in accordance with NZS 4603 Part 4, and
- b) Connected only to open vented *storage water heaters*, or open vented storage water vessels (see Figure 15), and
- c) Installed using copper pipework between the wet-back and the *water tank*, and
- d) The wet-back shall be made of copper.

Amend 5  
Feb 2004

Amend 13  
Nov 2023

Amend 5  
Feb 2004

Amend 13  
Nov 2023



Amend 5  
Feb 2004

Amend 13  
Nov 2023

**6.14 Safe water temperatures**

**6.14.1 Maximum temperatures**

The delivered hot water temperature at the outlet of any *sanitary fixture* used for personal hygiene shall not exceed:

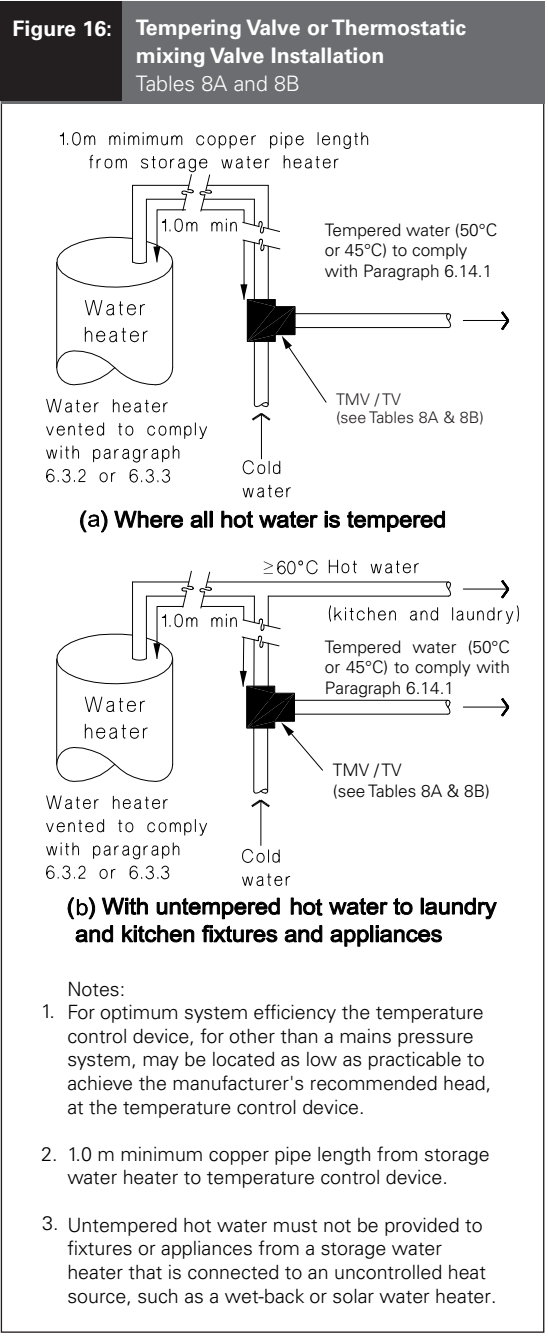
- a) 45°C for *early childhood education and care centres*, schools, old people’s homes, institutions for people with psychiatric or physical disabilities, hospitals, and
- b) 50°C for all other buildings.

**COMMENT:**

1. At greatest risk from scalding are children, the elderly, and people with physical or intellectual disabilities, particularly those in institutional care.
2. *Sanitary fixtures* used for personal hygiene includes showers, baths, hand basins and bidets.
3. For licensing purposes for *early childhood education and care centres*, the Ministry of Education requires the temperature of water delivered from taps that are accessible to children does not exceed 40°C.

**6.14.2 Delivery temperature control devices**

Devices for limiting the hot water temperature delivered to *sanitary fixtures* used for personal hygiene shall comply with Table 8A and Table 8B.



Amend 13  
Nov 2023  
Amend 5  
Feb 2004

Amend 13  
Nov 2023

**6.14.3 Legionella bacteria**

Irrespective of whether a delivery temperature control device is installed, the *storage water heater* control thermostat shall be set at a temperature of not less than 60°C to prevent the growth of Legionella bacteria.

Amend 13  
Nov 2023

Amend 5  
Feb 2004

**COMMENT:**

Alternative methods of controlling Legionella within hot water flow and return circulating or warm water systems are outside the scope of this acceptable solution, however these may include chlorine disinfection, UV sterilisation, high temperature pasteurisation combined with system flushing as part of a documented maintenance programme.

Amends  
5 & 13

**6.15 Energy Efficiency**

Systems for providing hot water to *sanitary fixtures* or *sanitary appliances* must be constructed to achieve an adequate degree of energy efficiency to comply with NZBC H1.3.4.

**COMMENT:**

NZS 4305 is referenced in Acceptable Solutions H1/AS1 and H1/AS2 as a means of complying with NZBC H1.3.4.

Amend 13  
Nov 2023

**Table 8A: Acceptable temperature control devices where a maximum delivery temperature of 45°C is required by Paragraph 6.14.1**  
Paragraph 6.14.2 and Figure 16

Device type	Standard
Thermostatic mixing valve (TMV) <sup>1234</sup>	AS 4032.1 BS EN 1287 (Low pressure) BS EN 1111 (High pressure)
Thermostatically controlled tap <sup>124</sup>	AS 4032.4
Notes:	
1. Temperature control device materials and components shall comply with Paragraph 2.0.	
2. Each thermostatic mixing valve or tempering valve shall have a <i>non-return valve</i> fitted to the hot and cold water supply. These devices may be fitted separately or form an integral part of the thermostatic mixing valve.	
3. See Figure 16 for acceptable methods of limiting hot water delivery temperature using a thermostatic mixing valve.	
4. Delivery temperature control devices require routine maintenance and performance testing. For information on maintenance, refer to AS 4032.3.	

**Table 8B: Acceptable temperature control devices where a maximum delivery temperature of 50°C is required by Paragraph 6.14.1**  
Paragraph 6.14.2 and Figure 16

Device type	Standard
Thermostatic mixing valve (TMV) <sup>1345</sup>	AS 4032.1 BS EN 1287 (Low pressure) BS EN 1111 (High pressure)
Thermostatically controlled tap <sup>15</sup>	AS 4032.4
Tempering valve (TV) <sup>134</sup>	AS 4032.2 NZS 4617
Instantaneous temperature limited water heater <sup>2</sup>	AS 3498
Notes:	
1. Temperature control device materials and components shall comply with Paragraph 2.0.	
2. An instantaneous temperature limited water heater is a water heater that limits the delivered hot water temperature at the outlet of any sanitary fixture used for personal hygiene supplied by the water heater	
3. Each thermostatic mixing valve or tempering valve shall have a <i>non-return valve</i> fitted to the hot and cold water supply. These devices may be fitted separately or form an integral part of the thermostatic mixing or tempering valve.	
4. See Figure 16 for acceptable methods of limiting hot water delivery temperature using a thermostatic mixing valve or tempering valve.	
5. Delivery temperature control devices require routine maintenance and performance testing. For information on maintenance, refer to AS 4032.3.	

Amend 13  
Nov 2023

Amend 13  
Nov 2023

**Table 9: Water Supply Pipework Support Spacing**  
Paragraph 7.1.3

Pipe material	Pipe diameter (mm)	Maximum distance between supports (m)	
		Vertical pipe	Graded and horizontal pipe
Copper	10 – 15	1.5	1.2
	20 – 25	2.0	1.5
uPVC	15 – 20	2.0	1.0
	25	2.4	1.2
Polyethylene and polybutylene (cold water supply)	15 – 20	1.5	0.75
	25	1.8	0.9
Polybutylene (hot water supply)	15 – 18	1.0	0.6
	20 – 22	1.4	0.7

Amend 13  
Nov 2023

**Note:**

The spacing for these pipe materials is based on the pipes being located within the *building* structure.



**7.0 Installation Methods**

**7.0.1** *Water supply systems* shall be installed to comply with the durability requirements of NZBC B2.

**7.1 Pipe supports**

**7.1.1** Pipes and their supports shall be electrochemically compatible.

**7.1.2** Except where anchor points are necessary, the pipes shall be installed and supported in a manner which permits thermal movement.

**7.1.3 Support spacing**

Above ground water supply pipework shall be securely supported at centres of no greater than those given in Table 9.

**7.1.4 Anchor points**

Anchor points shall be provided where:

- a) Seal ring joints are used, and
- b) The joint is not able to resist the thrust imposed by the water pressure.

**7.2 Protection from freezing**

**7.2.1** Where there is the likelihood of freezing, hot and cold *water supply systems* shall be protected in the following manner:

- a) Piping outside of the *building* thermal envelope shall be insulated,
- b) Piping buried in the ground shall be insulated or installed below a level affected by freezing, and
- c) *Storage water heater vent pipes* shall be insulated (see Figure 17).

**7.2.2** In climates where freezing temperatures are likely for a period of greater than 24 hours an expansion control valve is required in addition to *vent pipe* insulation (see Figure 17).

**7.3 Unintentional heating**

**7.3.1** Cold water supply systems shall be installed to avoid the likelihood of becoming unintentionally heated.

**COMMENT:**

Where installed in a location subjected to high temperatures (such as the roof space of a building during summer), cold water supply systems have the potential to become unintentionally heated. This can pose a hazard as the cold water supply may reach temperatures in excess of 45°C, increasing the risk of scalding and the growth of Legionella bacteria.

To reduce the likelihood of unintentional heating of cold *water supply systems*, consideration should be given to—

- a) avoiding long runs of pipework in locations exposed to solar heat gain,
- b) locating pipework within ceiling spaces under any insulating material laid for restricting heat losses through ceilings, and/or
- c) insulating the pipework.

Avoidance of unintentional heating of cold *water supply systems* in known areas of extreme summer temperatures may also assist in reducing water usage through drawing off of water which has become excessively heated.

**7.4 Protection from damage**

**7.4.1** Water supply pipes shall be protected from the likelihood of damage.

**7.4.2 Pipes below ground level**

An acceptable method of protecting water supply pipes is to provide the minimum covers given below:

**Cover Location**

600 mm	Residential driveways and similar areas subjected to occasional heavy traffic
300 mm	Gardens, lawns, paths and paving for pedestrian use or other areas not subjected to vehicular traffic

**7.4.3 Movement in concrete or masonry**

Pipes penetrating concrete or masonry elements shall be either wrapped with a flexible material, or passed through a sleeve or duct, to permit free movement for expansion and contraction.

Pipework in or under a concrete slab must be installed in a manner to achieve a 50 year durability.

Amend 13  
Nov 2023

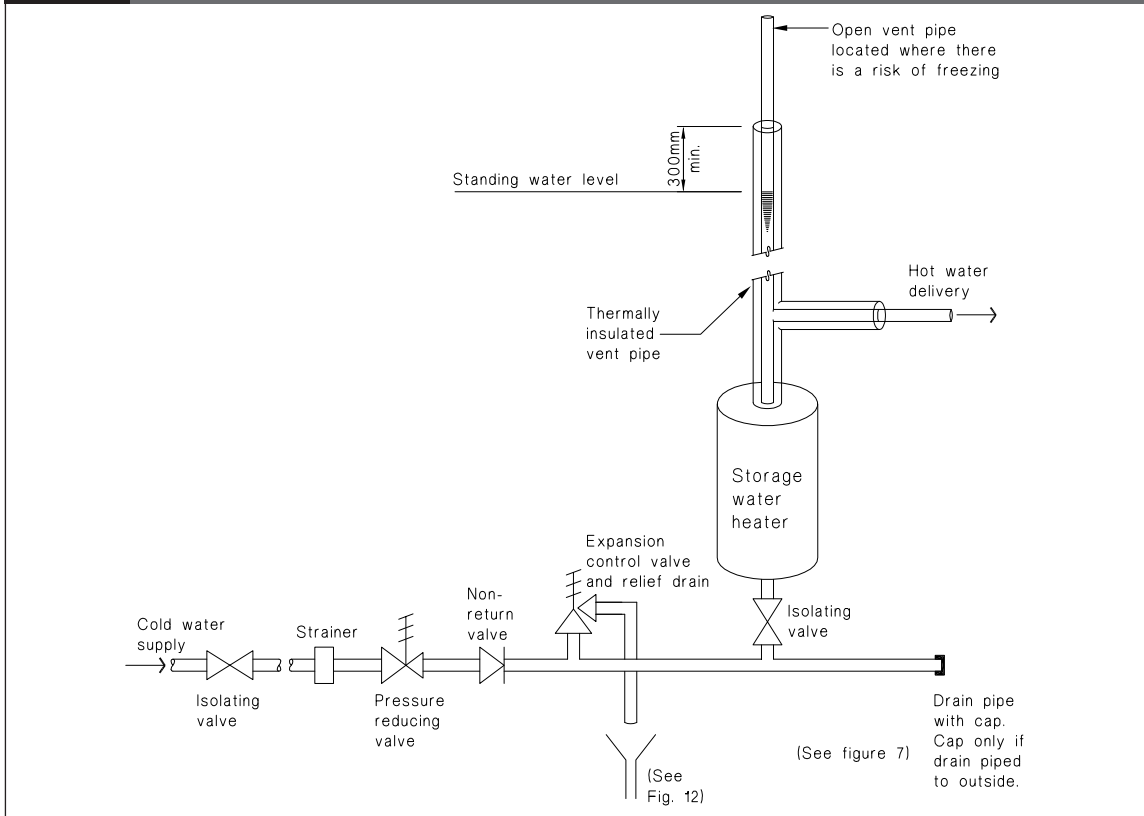
Amend 13  
Nov 2023

Amend 13  
Nov 2023

Amend 13  
Nov 2023

Amend 13  
Nov 2023

**Figure 17: Open Vented Storage Water Heaters in Climates Subject to Freezing**  
Paragraphs 7.2.1 c) and 7.2.2



Third Edition  
Dec 2007

**7.5 Installation of pipework systems**

**7.5.1** Acceptable methods of installing pipework systems are given in Table 10.

<b>Table 10: Acceptable Methods of Installing Pipework</b> Paragraph 7.5.1	
<b>Material</b>	<b>Relevant Standard</b>
PVC-U	AS/NZS 2032
Polyethylene	AS/NZS 2033
Copper	AS 4809

Note:  
The installation of pipework systems shall take into account manufacturers information and installation instructions.

**7.6 Watertightness**

**7.6.1** The *water supply system* shall be tested to ensure watertightness. An acceptable testing method is to:

- a) Subject the hot and cold system to a pressure of 1500 kPa for a period of not less than 15 minutes, and
- b) Inspect the system to ensure that there are no leaks.

**COMMENT:**

- 1. Testing should be carried out before concealing pipework behind interior linings, flooring or within concrete, or before backfilling trenches.

2. All *fixtures, appliances, water tanks, storage water heaters* and other equipment, which may be damaged during pressure testing, should be isolated before testing.

**7.6.2** Another acceptable method for testing PVC-U pipework systems is given in AS/NZS 2032 Section 7.

**7.7 Flushing**

**7.7.1** Newly installed and altered water supply systems shall be flushed at each discharge point to remove any dirty water or debris on completion of construction.

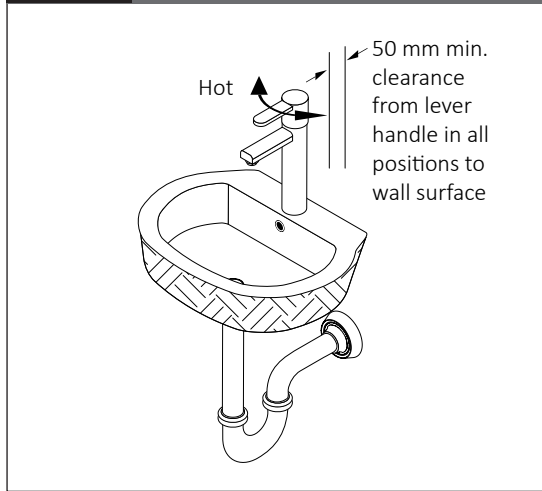
Amend 13  
Nov 2023

Third Edition  
Dec 2007

Amend 9  
Feb 2014

Amend 13  
Nov 2023

**Figure 18: Accessible Single Lever Tap**  
Paragraph 8.0.1



Amend 13  
Nov 2023

Amend 13  
Nov 2023

**8.0 Taps for People with Disabilities**

**8.0.1** Where taps are likely to be used for personal hygiene or the washing of utensils by *people with disabilities*, they shall have (see Figure 18):

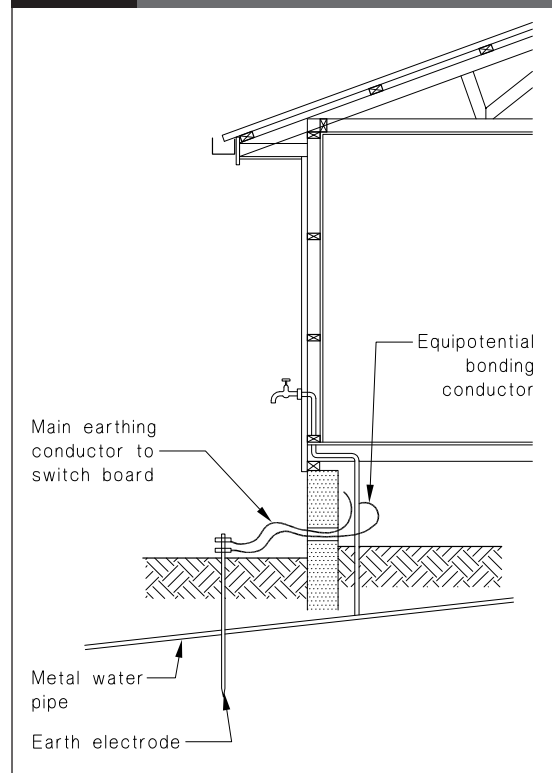
- a) Single lever handles or sensor plates that activate the tap automatically when hands are placed under them,
- b) Not less than 50 mm clearance between a lever handle in all positions and any adjacent surface, and
- c) Hot water provided when a lever handle is positioned to the left and cold water when a handle is positioned to the right.

Amend 13  
Nov 2023

**COMMENT:**

This requirement does not apply to Housing, Outbuildings, Ancillary *buildings*, and Industrial *buildings* employing fewer than 10 people.

**Figure 19: Equipotential Bonding of Metallic Water Supply Pipe**  
Paragraph 9.2.1 a)



**9.0 Equipotential Bonding**

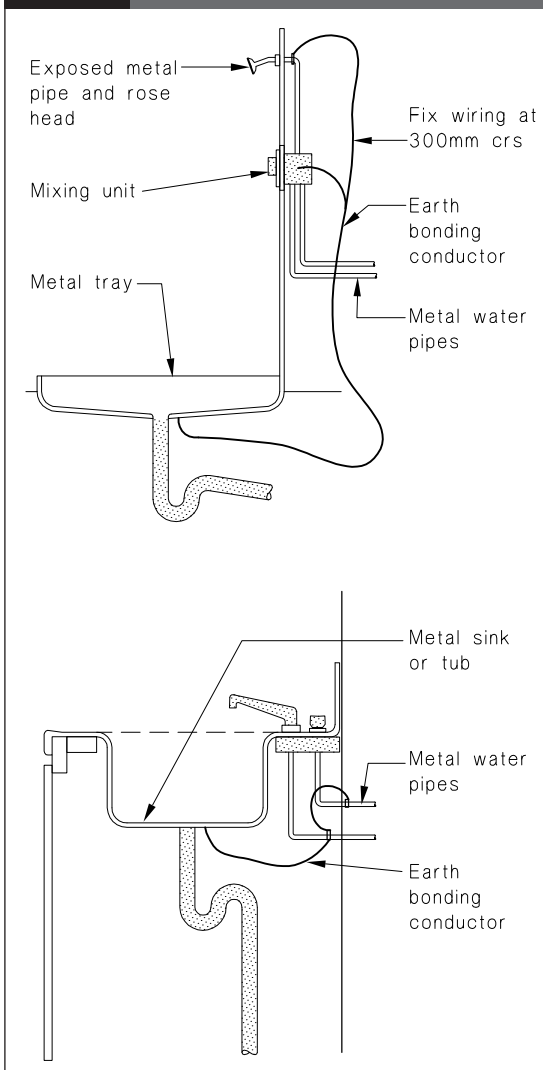
**9.1 General**

**9.1.1** NZBC G9 requires any electrical installation within a *building* to be constructed to protect users from the dangers of contact with parts of the *building* that may become live during fault conditions.

**9.1.2** Equipotential bonding is required where all of the following conditions are likely to exist:

- a) Electricity is provided within a *building*,
- b) The water supply pipe is metallic,
- c) *Building* users are able to make contact with exposed parts of metal water supply pipe, or any metallic *sanitary fixtures* connected to it, and
- d) The metal pipe is in contact with the ground, and forms a continuous metallic link from the ground to those parts of the pipe exposed to *building* users.

**Figure 20: Equipotential Bonding of Metallic Sanitary Fixtures**  
Paragraph 9.2.2 a)



**COMMENT:**

No equipotential bonding is required if the water supply piping is plastic.

**9.2 Installation of equipotential bonding conductors**

**9.2.1 Water supply pipe**

- a) Metallic water supply pipe shall be bonded to the earth electrode with an equipotential bonding conductor, as shown in Figure 19. The connection to the water pipe shall be as close as practicable to the point where the pipe leaves the ground, and
- b) Metallic hot and cold water supply pipes shall be bonded together.

**9.2.2 Metallic sanitary fixtures**

- a) Metallic *sanitary fixtures* shall be bonded to the metallic water supply pipe with an equipotential bonding conductor, as shown in Figure 20.

**COMMENT:**

Metallic *sanitary fixtures* are only required to be bonded to metallic water supply pipes where it is possible for a person to simultaneously touch the pipe (via a tap) and the *fixture*.

- b) The bonding conductor shall be connected directly to the *sanitary fixture*. The bonding conductor may connect to the waste pipe where a metallic waste pipe is connected to the *sanitary fixture* and a continuous metallic link is formed between the waste pipe and the *fixture*.

**9.3 Earth bonding conductors**

**9.3.1** Earth bonding conductors shall be:

- a) Made of copper and have a cross-sectional area no less than 4.0 mm<sup>2</sup>,
- b) Sheathed with insulating material coloured green, and
- c) Fixed at intervals of no greater than 300 mm with aluminium cable fixings.

**9.3.2** Earth bonding conductors shall comply with AS/NZS 5000.1 or AS/NZS 5000.2 as appropriate.

Amend 7  
Sep 2010  
Amend 8  
Oct 2011

# Acceptable Solution G12/AS2

## Solar Water Heaters

### 1.0 Scope

**1.0.1** This Acceptable Solution applies to solar water heaters installed in or on buildings.

**1.0.2** To comply with this Acceptable Solution solar water heaters must also comply with the appropriate requirements of G12/AS1. This Acceptable Solution meets the requirements of NZBC Clauses B1, B2, E2, G12 and H1.

**1.0.3** Text boxes headed '**COMMENT**' occurring throughout this document are for guidance purposes only.

### 1.1 Structural support limitations

**1.1.1** Where a building has not been specifically designed to support a solar water heater, this Acceptable Solution can be used for the support and fixing of a solar collector on buildings that meet the structural requirements specified in any one of the following:

- NZS 3604: 1990
- NZS 3604: 1999
- NZS 3604: 2011
- NZS 4203
- AS/NZS 1170: Parts 0, 1, 2, 3 and NZS 1170: Part 5.

But only when all of the following requirements are met:

- a) the weight of solar collector, including frames, fittings, and heat transfer fluid, has a combined weight of no more than 22 kg per square metre (based on the gross area of the solar collector), and
- b) the hot water storage tank is not installed on or above the roof, and
- c) where the hot water storage tank is located within a roof it has a maximum size of:
  - i) 200 litres when installed in accordance with NZS 3604: 1999 Section 14, or
  - ii) 450 litres when installed in accordance with AS/NZS 3500 Part 4 Section 5, and

- d) the roof has a pitch no steeper than 45°, and
- e) the building is in a wind zone where wind speeds do not exceed 50 m/s (VH wind zone defined in NZS 3604: 1999), and
- f) the solar collector has an area no greater than 4 m<sup>2</sup>, and
- g) the design ground snow loading for the building is less than:
  - (i) 0.5 kPa as determined by NZS 4203, or NZS 3604: 1990 or NZS 3604: 1999 Section 15, or
  - (ii) 1.0 kPa as determined by AS/NZS 1170 or NZS 3604: 2011, Section 15, and
- h) either:
  - i) the solar collectors are installed parallel to the roof cladding, or
  - ii) where solar collectors are installed at a different pitch to the pitch of the roof:
    - the pitch of the solar collector is not greater than 45° to the horizontal, and
    - the building is in a wind zone where wind speeds do not exceed 44 m/s (H wind zone defined in NZS 3604: 1999), and
    - the solar collector faces in the same compass direction as the section of roof the solar collector is installed on.

#### COMMENT:

1. The limitations described in Paragraph 1.1.1 are necessary, because roofs are likely to have limited capacity to support additional loads.

**1.1.2** When any of the requirements described in Paragraph 1.1.1 are not met, specific engineering design is required.

#### COMMENT:

Specific engineering design will require a structure assessment to be completed. This may result in either an assessment that the roof structure is sufficient to support the additional load or details of how to strengthen the roof structure to support the additional load.

Amend 8  
Oct 2011

Amend 8  
Oct 2011

Amend 10  
Jan 2017

## 1.2 Exclusions

**1.2.1** If the solar *water heater* includes connection to an application such as underfloor heating, a swimming pool or any similar application, this Acceptable Solution applies only to the solar *water heater* and its components and not to the application.

## 2.0 Materials

### 2.1 Material selection

**2.1.1** All material used to install the solar *water heater* must:

- a) meet the *durability* requirements of NZBC Clause B2, and
- b) be suitable for their use, location and environment as shown in Table 1, and
- c) be compatible with adjoining materials as shown in Table 2, and
- d) be compatible with materials subject to run-off as shown in Table 3 (except as described in Paragraph 2.1.2).

**2.1.2** Table 3 states that “butyl/EPDM” to “steel, galvanized unpainted” is “not permitted”; however, water flow from small areas of **EPDM** will not significantly affect the *durability* of the roofing. Therefore it is acceptable to use unpainted **EPDM** boots with unpainted galvanised steel roofing if:

- a) the boots are small (for 60 mm pipe diameter or smaller), and
- b) there are no more than 10 boots used for the solar *water heater* installation, and
- c) the boots contain no greater than 15% carbon black.

**2.1.3** If the requirements described in Paragraph 2.1.2 are not met then either the **EPDM** boots or the galvanised roofing must be painted with a suitable protective coating.

**2.1.4** Table 2 shows that galvanized fixings must be used rather than stainless steel when in contact with galvanized *cladding* and zinc-aluminium-magnesium (combinations) coated *cladding*. (This includes mounting brackets and straps.)

Amend 9  
Feb 2014

**Table 1: Material selection (reproduced from E2/AS1 Table 20)**  
This table shall be read in conjunction with Tables 2 and 3 and Paragraphs 2.1.1, 2.1.2, 2.1.3 and 2.1.4

Material	Exposure(1)(2)(4)(6)		Acceptable Exposure Zones as per NZS 3604 – Section 4 (3)(4)(6)	
	NOTE: Consider all walls as 'Sheltered' for steel based claddings(8)	Type	15 years	50 years for hidden elements(2)(9)
<b>CLADDINGS AND FLASHINGS</b>				
Aluminium, zinc	Hidden(2)		B,C,D,E	B,C,D,E
	Exposed		B,C,D,E	
	Sheltered		B,C,D,E	
Copper, lead, or stainless steel	Hidden(2)		B,C,D,E	B,C,D, E
	Exposed		B,C,D,E	
	Sheltered		B,C,D,E	
<b>Factory painted</b>				
Aluminium-zinc-magnesium (combinations) coated or galvanised steel, to AS 1397 and AS/NZS 2728 with AM100, ZM274, and AZ150 minimum coatings	Hidden(9)	Type 4	B,C,D,E	B,C,D
	Hidden(9)	Type 6	B,C,D,E	B,C,D,E
	Exposed(8)	Type 4	B,C,D	
	Exposed(8)	Type 6	B,C,D,E	
	Sheltered	Type 4	B,C	
Pressed metal tiles coated to minimum AZ150 or AM100 to AS 1397, AS/NZS 2728 or with post-form factory painting to cl 8.3.4.2.	Exposed	Type 6	B,C,D,E	
	Sheltered	Type 6	B,C,D	
<b>Non-factory painted</b>				
Aluminium-zinc-magnesium (combinations) coated steel, to AS 1397 with AZ150 or AM125 minimum coatings	Hidden(9)		B,C,D,E	B,C,D
	Exposed(8)		B,C	
	Sheltered		B	
Galvanised steel Z450 to AS 1397	Hidden(9)		B,C,D	B,C
	Exposed(8)		B,C	
	Sheltered		B	
<b>Non-metallic</b>				
Bituminous material, or uPVC	Hidden		B,C,D,E	B,C,D,E
	Exposed (uPVC only)		B,C,D,E	
	Sheltered (uPVC only)		B,C,D,E	
Butyl rubber	Hidden		B,C,D,E	B,C,D,E
	Exposed		B,C,D,E	
	Sheltered		B,C,D,E	
<b>FIXINGS(7)</b>				
Aluminium, bronze, and stainless steel (Types 304 and 316)(10)	Hidden		B,C,D,E	B,C,D,E
	Exposed		B,C,D,E	
	Sheltered		B,C,D,E	
Nails – Hot-dip galvanised steel to AS/NZS 4680	Hidden(5)(9)		B,C,D	B,C
	Exposed		B,C,	
	Sheltered		B	
Screws – galvanised steel, painted or unpainted, to AS 3566: Part 2	Hidden(5)(9)	Class 3	B,C,D,E(3)(4)	B,C,D,E
	Exposed	Class 4	B,C,D	
	Sheltered	Class 4	B,C	

Amend 9  
Feb 2014

**Table 1: Material selection – continued****Note:**

- 1) Refer to manufacturer's information for maintenance requirements in Exposed and Sheltered locations.
- 2) The term "hidden" means concealed behind another element such that no part is visible. Hidden elements require a 50 year *durability* under the NZBC. The term "exposed" means having surfaces exposed to rain washing. The term 'sheltered' means being visible, but not rain washed. For diagrammatic outline, refer NZS 3604 Figure 4.3(a). Exposed and sheltered elements require a 15 year *durability*. Where an element can be categorised as both 'sheltered' and 'exposed', the 'sheltered' condition will apply.
- 3) AS/NZS 2728 lists atmospheric classes derived from ISO 9223 for Australia and New Zealand, determined by exposure to wind-driven sea-spray. NZS 3604 references atmospheric classes B (Low), C (Medium) and D (High). E2/AS1 references atmospheric zones B,C,D,E. For the purposes of *cladding* selection, Zone E (Severe marine classified as breaking surf beach fronts) has been included. Designers must consult metal supplier's information for specific *durability* requirements of sites in Zone E.
- 4) The geographic limits of atmospheric classes in NZS 3604 and AS/NZS 2728 may vary. Table 1 uses the limits outlined in NZS 3604.
- 5) Includes fixings protected by putty and an exterior paint system of primer, undercoat and two top coats of paint.
- 6) Microclimates based on evidence from adjacent structures of corrosion caused by industrial or geothermal atmospheres are outside the scope of this Acceptable Solution.
- 7) Refer to Tables 2 and 3 for compatibility of fixings with metal *claddings*.
- 8) *Roof* only. Coated steel *wall claddings* must be considered as 'sheltered'.
- 9) Hidden steel coated elements in ventilated cavities in zones D and E (exposure to salt air) must be considered as 'sheltered'.
- 10) The use of stainless steel fixings is not recommended by steel manufacturers for use with coated steel in severe marine and industrial environments, as they are considered to cause deterioration.

Amend 9  
Feb 2014



**This page deliberately left blank**

**Table 2: Compatibility of materials in contact**

This table must be read in conjunction with Tables 1 and 3 and Paragraphs 2.1.1., 2.1.2, 2.1.3 and 2.1.4

	Aluminium, anodised or mill-finish	Aluminium, coated (1)	Butyl rubber & EPDM	CCA-treated timber (2)	Cedar	Cement plaster (uncoated)	Ceramic tiles (cement grout)	Clay bricks (cement mortar)	Concrete old (unpainted)	Concrete green (unpainted)	Copper/brass	Glass	Glazed roof tiles	Lead (including lead-edged) unpainted	Plastics	Stainless steel	Steel, galvanised coil-coated	Steel, galvanized (unpainted)	Zinc	Zinc-aluminium-magnesium (combinations), coated (1)	Zinc-aluminium-magnesium (combinations), (unpainted)
Aluminium, anodised or mill-finish	✓	✓	✓	✗	✓	✗	✗	✗	✓	✗	✗	✓	✓	✗	✓	B	✓	✓	✓	✓	✓
Aluminium, coated (1)	✓	✓	✓	B	✓	✗	✗	✗	✓	✗	✗	✓	✓	B	✓	B	✓	✓	✓	✓	✓
Butyl rubber & EPDM	✓	✓	✓	✓	✓	✓	✓	✓	✓	✓	✓	✓	✓	✓	✓	✓	✓	✓	✓	✓	✓
CCA-treated timber (2)	✗	B	✓	✓	✓	✓	✓	✓	✓	✓	✓	✓	✓	✓	✓	✓	B	✗	✗	B	✗
Cedar	✓	✓	✓	✓	✓	✓	✓	✓	✓	✓	✓	✓	✓	✓	✓	✓	✓	✗	✗	✓	✗
Cement plaster (uncoated)	✗	✗	✓	✓	✓	✓	✓	✓	✓	✓	✓	✓	✓	✗	✓	✓	✓	✓	✓	✓	✗
Ceramic tiles (cement grout)	✗	✗	✓	✓	✓	✓	✓	✓	✓	✓	✓	✓	✓	✓	✓	✓	✓	✓	✓	✓	✗
Clay bricks (cement mortar)	✗	✗	✓	✓	✓	✓	✓	✓	✓	✓	✓	✓	✓	✓	✓	✓	✓	✓	✓	✓	✗
Concrete old (unpainted)	✓	✓	✓	✓	✓	✓	✓	✓	✓	✓	✓	✓	✓	✓	✓	✓	✓	✓	✓	✓	✓
Concrete green (unpainted)	✗	✗	✓	✓	✓	✓	✓	✓	✓	✓	✓	✓	✓	✗	✓	✓	✗	✗	✗	✗	✗
Copper/brass	✗	✗	✓	✓	✓	✓	✓	✓	✓	✓	✓	✓	✓	B	✓	B	✗	✗	✗	✗	✗
Glass	✓	✓	✓	✓	✓	✓	✓	✓	✓	✓	✓	✓	✓	✓	✓	✓	✓	✓	✓	✓	✓
Glazed roof tiles	✓	✓	✓	✓	✓	✓	✓	✓	✓	✓	✓	✓	✓	✓	✓	✓	✓	✓	✓	✓	✓
Lead (including lead-edged) unpainted	✗	B	✓	✓	✓	✗	✓	✓	✓	✗	B	✓	✓	✓	✓	B	B	B	B	B	✗
Plastics	✓	✓	✓	✓	✓	✓	✓	✓	✓	✓	✓	✓	✓	✓	✓	✓	✓	✓	✓	✓	✓
Stainless steel	B	B	✓	✓	✓	✓	✓	✓	✓	✓	B	✓	✓	B	✓	✓	B	✗	✗	B	B
Steel, galvanised coil-coated	✓	✓	✓	B	✓	✓	✓	✓	✓	✗	✗	✓	✓	B	✓	B	✓	✓	✓	✓	✓
Steel, galvanized (unpainted)	✓	✓	✓	✗	✗	✓	✓	✓	✓	✗	✗	✓	✓	B	✓	✗	✓	✓	✓	✓	✓
Zinc	✓	✓	✓	✗	✗	✓	✓	✓	✓	✗	✗	✓	✓	B	✓	✗	✓	✓	✓	✓	✓
Zinc-aluminium-magnesium (combinations), coated (1)	✓	✓	✓	B	✓	✓	✓	✓	✓	✗	✗	✓	✓	B	✓	B	✓	✓	✓	✓	✓
Zinc-aluminium-magnesium (combinations) (unpainted)	✓	✓	✓	✗	✗	✗	✗	✗	✓	✗	✗	✓	✓	✗	✓	B	✓	✓	✓	✓	✓

**LEGEND:**

- ✓ Materials satisfactory in contact.
- ✗ Contact between materials is not permitted. Minimum gap of 5 mm is required to prevent moisture bridging.
- B Avoid contact in sea-spray zone or corrosion zone D.

**NOTES:**

- (1) Coated – includes factory-painted, coil-coated and powder-coated.
- (2) Includes copper azole and copper quaternary salts.

Amend 9  
Feb 2014

**Table 3: Compatibility of materials subject to run-off**  
 This table must be read in conjunction with Tables 1 and 2 and Paragraphs 2.1.1., 2.1.2, 2.1.3 and 2.1.4

Material that water flows onto	Aluminium, anodised or mill-finish	Aluminium, coated (1)	Butyl rubber & EPDM	CCA-treated timber (2)	Cedar	Cement plaster (uncoated)	Ceramic tiles (cement grout)	Clay bricks (cement mortar)	Concrete old (unpainted)	Concrete green (unpainted)	Copper/brass	Glass	Glazed roof tiles	Lead (including lead-edged) unpainted	Plastics	Stainless steel	Steel, galvanised coil-coated	Steel, galvanized (unpainted)	Zinc	Zinc-aluminium-magnesium (combinations), coated (1)	Zinc-aluminium-magnesium (combinations), (unpainted)
Aluminium, anodised or mill-finish	✓	✓	✓	✓	✓	✓	✓	✓	✓	✓	✓	✓	✓	✓	✓	✓	✓	✓	✓	✓	✓
Aluminium, coated (1)	✓	✓	✓	✓	✓	✓	✓	✓	✓	✓	✓	✓	✓	✓	✓	✓	✓	✓	✓	✓	✓
Butyl rubber & EPDM	✓	✓	✓	✓	✓	✓	✓	✓	✓	✓	✓	✓	✓	✓	✓	✓	✓	✓	✓	✓	✓
CCA-treated timber (2)	✗	✗	✓	✓	✓	✓	✓	✓	✓	✓	✓	✓	✓	✓	✓	✓	✗	✗	✗	✗	✗
Cedar	✓	✓	✓	✓	✓	✓	✓	✓	✓	✓	✓	✓	✓	✓	✓	✓	✓	✓	✓	✓	✓
Cement plaster (uncoated)	✗	✗	✓	✓	✓	✓	✓	✓	✓	✓	✓	A	✓	✗	✓	✓	✓	✓	✓	✓	✓
Ceramic tiles (cement grout)	✗	✗	✓	✓	✓	✓	✓	✓	✓	✓	✓	A	✓	✓	✓	✓	✓	✓	✓	✓	✓
Clay bricks (cement mortar)	✗	✗	✓	✓	✓	✓	✓	✓	✓	✓	✓	A	✓	✓	✓	✓	✓	✓	✓	✓	✓
Concrete old (unpainted)	✓	✓	✓	✓	✓	✓	✓	✓	✓	✓	✓	A	✓	✓	✓	✓	✓	✓	✓	✓	✓
Concrete green (unpainted)	✗	✗	✓	✓	✓	✓	✓	✓	✓	✓	✓	A	✓	✗	✓	✓	✗	✗	✗	✗	✗
Copper/brass	✗	✗	✓	✓	✓	✓	✓	✓	✓	✓	✓	✓	✓	✓	✓	✓	✗	✗	✗	✗	✗
Glass	✓	✓	✓	✓	✓	✓	✓	✓	✓	✓	✓	✓	✓	✓	✓	✓	✓	✓	✓	✓	✓
Glazed roof tiles	✓	✓	✓	✓	✓	✓	✓	✓	✓	✓	✓	✓	✓	✓	✓	✓	✓	✓	✓	✓	✓
Lead (including lead-edged) unpainted	✗	✗	✓	✓	✓	✓	✓	✓	✓	✓	✓	✓	✓	✓	✓	✓	✓	✓	✓	✓	✗
Plastics	✓	✓	✓	✓	✓	✓	✓	✓	✓	✓	✓	✓	✓	✓	✓	✓	✓	✓	✓	✓	✓
Stainless steel	✓	✓	✓	✓	✓	✓	✓	✓	✓	✓	✓	✓	✓	✓	✓	✓	✓	✓	✓	✓	✓
Steel, galvanised coil-coated	✓	✓	✓	✓	✓	✓	✓	✓	✓	✓	✓	✓	✓	✓	✓	✓	✓	✓	✓	✓	✓
Steel, galvanized (unpainted)	✓	✓	✓	✓	✓	✓	✓	✓	✓	✓	✓	✓	✓	✓	✓	✓	✓	✓	✓	✓	✓
Zinc	✓	✓	✓	✓	✓	✓	✓	✓	✓	✓	✓	✓	✓	✓	✓	✓	✓	✓	✓	✓	✓
Zinc-aluminium-magnesium (combinations), coated (1)	✓	✓	✓	✓	✓	✓	✓	✓	✓	✓	✓	✓	✓	✓	✓	✓	✓	✓	✓	✓	✓
Zinc-aluminium-magnesium (combinations) (unpainted)	✓	✓	✓	✓	✓	✓	✓	✓	✓	✓	✓	✓	✓	✓	✓	✓	✓	✓	✓	✓	✓

**LEGEND:**

- ✓ Materials satisfactory with water run-off as indicated.
- ✗ Water run-off is not permitted as indicated.
- A Etching or staining of glass may occur with run-off.

**NOTES:**

- (1) Coated – includes factory-painted, coil-coated and powder-coated.
- (2) Includes copper azole and copper quaternary salts.

Amend 9  
Feb 2014

Amend 9  
Feb 2014

### 3.0 Solar Water Heater Requirements

#### 3.1 Solar water heaters and components

**3.1.1** Solar *water heaters* must comply with AS/NZS 2712

**3.1.2** Tanks installed as part of a pumped solar *water heater* where the tank is separately mounted from the collector must comply with the minimum tank insulation requirements of AS/NZS 4692.2.

#### COMMENT:

AS/NZS 4692.2: 2005 specifies Minimum Energy Performance Standard (MEPS) requirements for electric *water heaters*. Clause 1.4 of this Standard excludes solar *water heaters*. Paragraph 3.1.2 of this Acceptable Solution modifies this exclusion so that hot water tanks mounted separately from solar collectors used in a solar *water heater* must now comply with the MEPS requirements specified in AS/NZS 4692.2: 2005.

#### 3.2 Solar controller

**3.2.1** Where a solar *water heater* has a controller, the controller must meet the requirements specified in AS/NZS 2712: clause 6.3.

**3.2.2** The controller or the solar *water heater* design must minimise the use of supplementary heating while meeting the requirements described in Paragraph 3.5.

**3.2.3** A solar *water heater* which meets the requirements described in Paragraphs 3.2.1 and/or 3.2.2 satisfies NZBC Clause H1.3.4.

#### 3.3 Sizing of systems

**3.3.1** Solar *water heaters* must have a minimum of 50 litres of hot water storage per square metre of collector area.

#### COMMENT:

The sizing requirement described in Paragraph 3.3.1 is to prevent overheating of the system. The capacity of the tank should not be less than one day's expected use. For most houses the expected hot water consumption is 40–60 litres per person per day when stored at 60°C.

#### 3.4 Operating and safety devices

**3.4.1** Storage tanks in solar *water heaters* must have operating and safety devices that meet the requirements of G12/AS1 Paragraph 6.

**3.4.2** Water from the installed system must not discharge onto the roof. *Vent pipes* and outlets from pressure relief valves must be plumbed to a suitable drain point.

#### 3.5 Protection from Legionella bacteria

**3.5.1** To prevent the growth of Legionella bacteria, solar *water heaters* must either:

- a) have a continuously energised heating element fitted within 55% of the bottom of the *water tank* (by volume) and a thermostat set to 60°C or higher, or
- b) be controlled so that the water above the element is heated to 60°C once a day, and the element is in the bottom 20% of the *water tank* (by volume) and no more than 150 mm from the bottom of the tank, or
- c) be controlled so that all of the stored water is heated to 60°C or higher, once a week for not less than 1 hour. The temperature must be measured by a probe in the bottom 20% of the *water tank* (by volume) and no more than 150 mm from the bottom of the water tank. For open loop systems the stored water includes the water in the solar collector and water must be circulated through the collector during the heating period.

**3.5.2** Where the solar *water heater* stores potable water and is used as a pre-heater for an instantaneous *water heater*, either:

- a) the hot water storage tank connected to the solar collector must be fitted with supplementary heating and a controller operating to meet the conditions outlined in Paragraph 3.5.1, or
- b) the instantaneous *water heater* must heat all water passing through it to not less than 70°C.

Amend 9  
Feb 2014

Amend 9  
Feb 2014

**3.5.3** Where the solar *water heater* supplies inlet water to a *storage water heater* with an element in the bottom 20% of the water tank (by volume) and no more than 150 mm from the bottom of the tank with a thermostat set to no less than 60°C, no additional Legionella control is required.

**COMMENT:**

Paragraph 3.5 of this Acceptable Solution provides ways to demonstrate that the NZBC Clause G12.3.9 (i.e. "A hot water system must be capable of being controlled to prevent the growth of Legionella bacteria") is satisfied. This is a heat disinfection method which is considered the most effective method to control Legionella.

The heating required to control the growth of Legionella does not necessarily have to be achieved using supplementary electric heating; it could also be achieved using gas, solar or wood as a heating fuel.

**3.6 Protection from frosts**

**3.6.1** For protection from freezing, collectors installed in climate zones 1 and 2 (as shown in Figure 1) must:

a) pass the level 1 test described in AS/NZS 2712 Appendix E, or

b) have an automatic drain-down system.

**3.6.2** For protection from freezing, collectors installed in climate zone 3 (as shown in Figure 1) must:

a) pass the level 2 test described in AS/NZS 2712 Appendix E, or

b) have an automatic drain-down system.

Amend 9  
Feb 2014

Amend 9  
Feb 2014

**Figure 1:** New Zealand climate zones for frost protection  
Paragraph 3.6

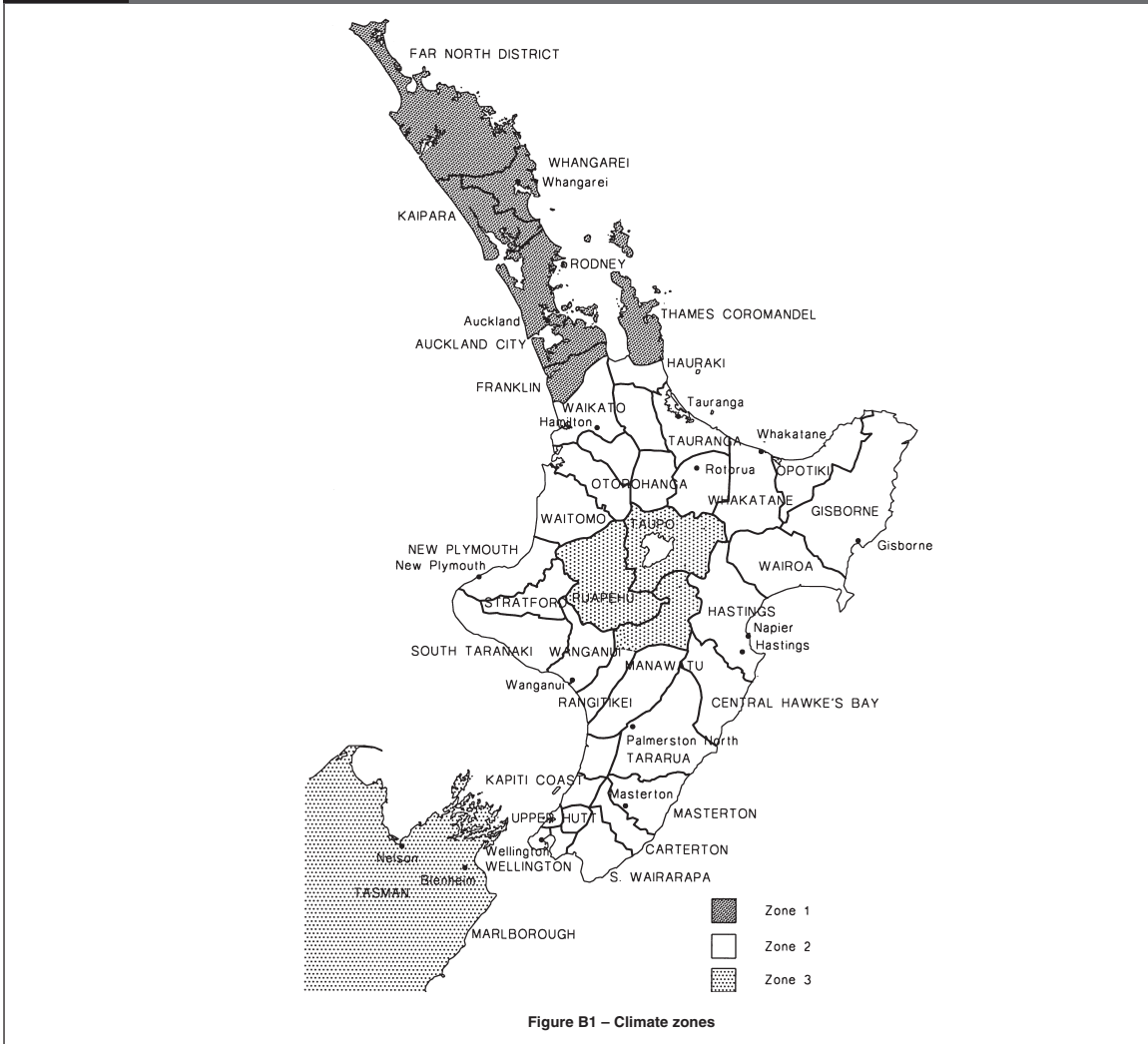


Figure B1 – Climate zones

Zone 3 includes all of the South Island, Stewart Island and the Chatham Islands  
Figure B1 from NZS 4218: 2004 is reproduced with permission of Standards New Zealand under Licence 684.

**4.0 Location of Solar Water Heaters**

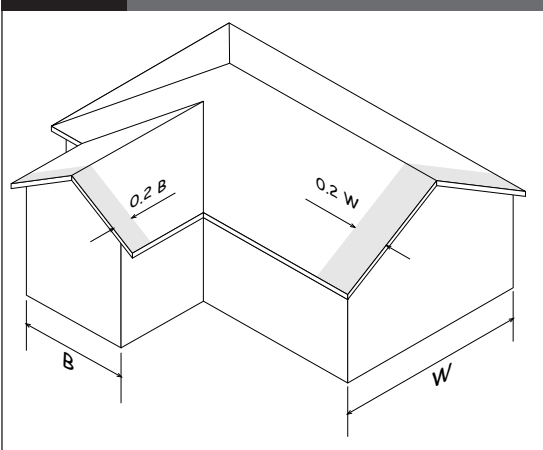
**4.1 Location**

**4.1.1** Solar water heaters must be located away from the edge of a gable roof structure outside the high pressure wind zone shown in Figure 2.

**4.2 Solar orientation and inclination**

**4.2.1** Solar collectors must face within +/- 90 degrees of geographic north (ie between east and west) to satisfy the requirements of NZBC Clause H1.3.4(a).

**Figure 2:** High pressure wind zone  
Paragraph 4.1



**4.2.2** Solar collectors must be inclined at an angle within +/- 20 degrees of the angle of latitude (from the horizontal) to satisfy the requirements of NZBC Clause H1.3.4(a).

**COMMENT:**

1. The ideal orientation of a solar collector is geographic north with an inclination angle from the horizontal the same as the angle of latitude for the location. Deviations from the ideal orientation will reduce the performance of the solar *water heater*.

Details of the impact of changes in orientation and inclination are provided in NZS 4614: 1986, and are shown in the following diagram.

**FACTORS FOR INCLINATION AND SOLAR ORIENTATION**

Direction (degrees)		Inclination angle (degrees)					
		0°	20°	40°	60°	80°	90°
West	270	0.85	0.85	0.8	0.72	0.6	0.53
	300	0.85	0.92	0.92	0.86	0.73	0.65
	330	0.85	0.98	0.99	0.93	0.8	0.71
North	0	0.85	0.97	1	0.94	0.8	0.7
	30	0.85	0.94	0.95	0.88	0.74	0.65
	60	0.85	0.88	0.86	0.77	0.65	0.57
East	90	0.85	0.8	0.73	0.64	0.52	0.46
Good orientation			Moderate orientation				Poor orientation

The relative performance of flat-plate collectors in different orientations is illustrated. It is clear that collectors should face within about 45° of north, and be fitted at an inclination angle between 20° and 50°.

If for some reason it were necessary to place the collectors facing the west at 60° inclination, then to avoid loss in performance, the collectors would have to be 1/0.72 (or 1.4) as large (i.e. increased by 40% in the collector area).

Where collectors other than flat-plate type (cylindrical shape for instance) are used, similar optimum requirements for orientation will apply (i.e. the axis of the cylinder should be inclined at 20° to 50°). The performance loss by using poorer orientation has not been as fully explored as for the flat-plate case.

Figure 12 from NZS 4614: 1986 is reproduced with the permission of Standards New Zealand under Licence 684.

2. Shading of solar collectors should be minimised to ensure maximum performance of the system.

Significant shading between 9:00 am and 3:00 pm will affect the performance of a solar *water heater*.

The solar altitude may be determined using a commercial "sun locator" or a simple solar altitude sight may be constructed using the diagrams given in AS/NZS 3500.4 Appendix H: Estimation of Shading of Collectors

Amends 10 and 12

**5.0 Installation of Solar Water Heaters**

**5.0.1** Solar *water heaters* must be installed in accordance with the requirements of AS/NZS 3500 Part 4, unless modified by this Acceptable Solution.

Amend 10 Jan 2017

**5.0.2** Water storage tanks that form part of a solar *water heater* must have drain pipes that:

- a) have an easily reached isolating valve, and terminate with a cap or plug to empty the vessel for maintenance, or
- b) terminate outside the *building* with a cap only.

**5.0.3** Fixings used for the installation of a solar *water heater* must meet the requirements described in Paragraphs 2.1.1, 2.1.2, 2.1.3 and 2.1.4.

**5.0.4** All metal swarf from drilling or cutting must be removed from the roof surface to prevent corrosion. Care must also be taken to avoid scratching of any roof *cladding* protective coating.

**5.1 Wetback water heaters**

**5.1.1** Where water is heated by a wetback *water heater* and a solar collector, independent water pipe circuits must be installed for each heat source.

**5.1.2** A wetback *water heater* must have an open-vent connected to the:

- a) *water tank*, or
- b) wetback *water heater* flow pipe (see G12/AS1 Figure 5).

**COMMENT:**

In Paragraph 5.1.2 (b) a heat-exchanger is required when the tank pressure is higher than the open-vented wetback circuit.

**5.2 Weathertightness**

**5.2.1** Any penetrations made in the *building cladding* during the installation of a solar *water heater* must be flashed, or sealed using purpose-made sealing washers or boots to prevent leaks.

**5.2.2** Where roof penetrations are required for large openings such as solar collectors installed in or below the roof:

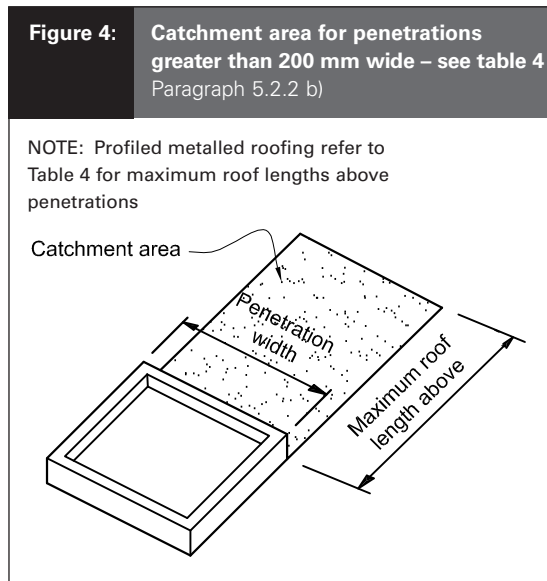
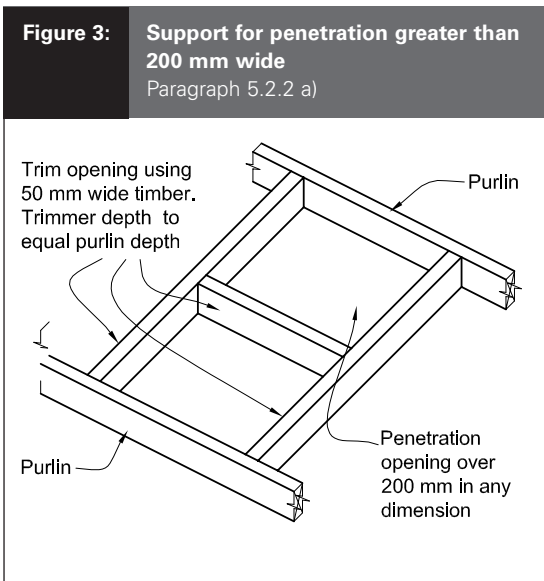
- a) the edge of roofing penetrations over 200 mm wide must be supported in either direction with additional *framing* as shown in Figure 3, and
- b) for the catchment area of the roof above the penetration as shown in Figure 4, the roof length must be limited to the areas shown in Table 4.

**5.2.3** Penetrations through masonry tile roofs must be as shown in Figure 5.

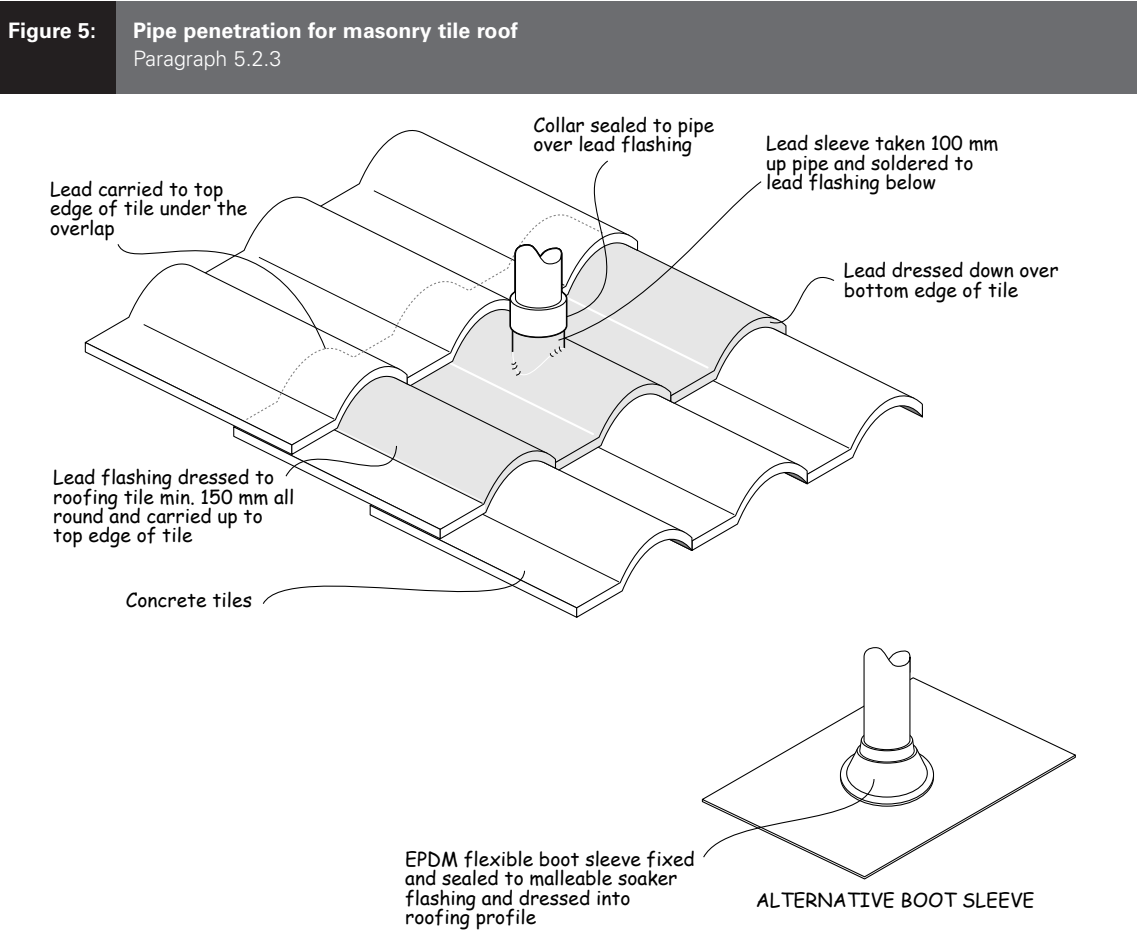
**5.2.4** Pipe penetrations in pressed metal tile roofs must be flashed using *EPDM* or silicone rubber boot *flashings* as shown in Figure 6.

**Table 4: Maximum catchment areas above penetrations greater than 200 mm wide**  
Paragraph 5.2.2 b)

Penetration width	Maximum roof length above penetration in metres			
	Profiled metal			
	Corrugated	Trapezoidal	Trough profile	Other roofs
800 to 1200 mm	4 m	8 m	16 m	4 m
600 to 800 mm	6 m	12 m	18 m	6 m
400 to 600 mm	8 m	16 m	18 m	8 m
200 to 400 mm	12 m	18 m	18 m	10 m







**5.2.5** Roof penetrations in profiled metal roofs must be flashed as follows.

- a) Pipe penetrations up to 85 mm diameter must be flashed using an *EPDM boot flashing* as shown in Figure 6, and
- b) Rectangular penetrations up to 1200 mm wide must be flashed using a soaker type *flashing* as shown in Figure 7.

**5.2.6** Penetrations on roofs will require *specific design* when:

- a) the pitch is less than 15° for concrete tile or pressed metal roofs, or
- b) the pitch is less than 10° for profiled metal roofs and the base of the boot flashing covers one or more complete troughs, or
- c) the penetration is larger than 85 mm, or
- d) the penetration requires specialised or complex *flashings*.

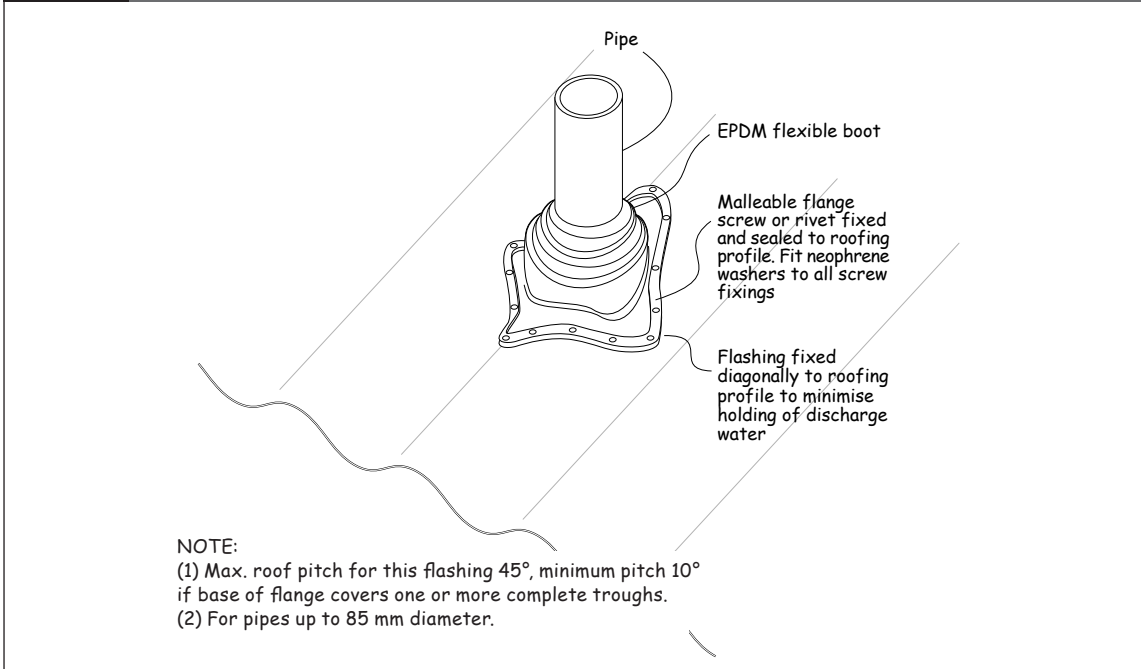
**COMMENT:**

The *cladding* manufacturer may be able to provide additional guidance.

Amend 13  
Nov 2023

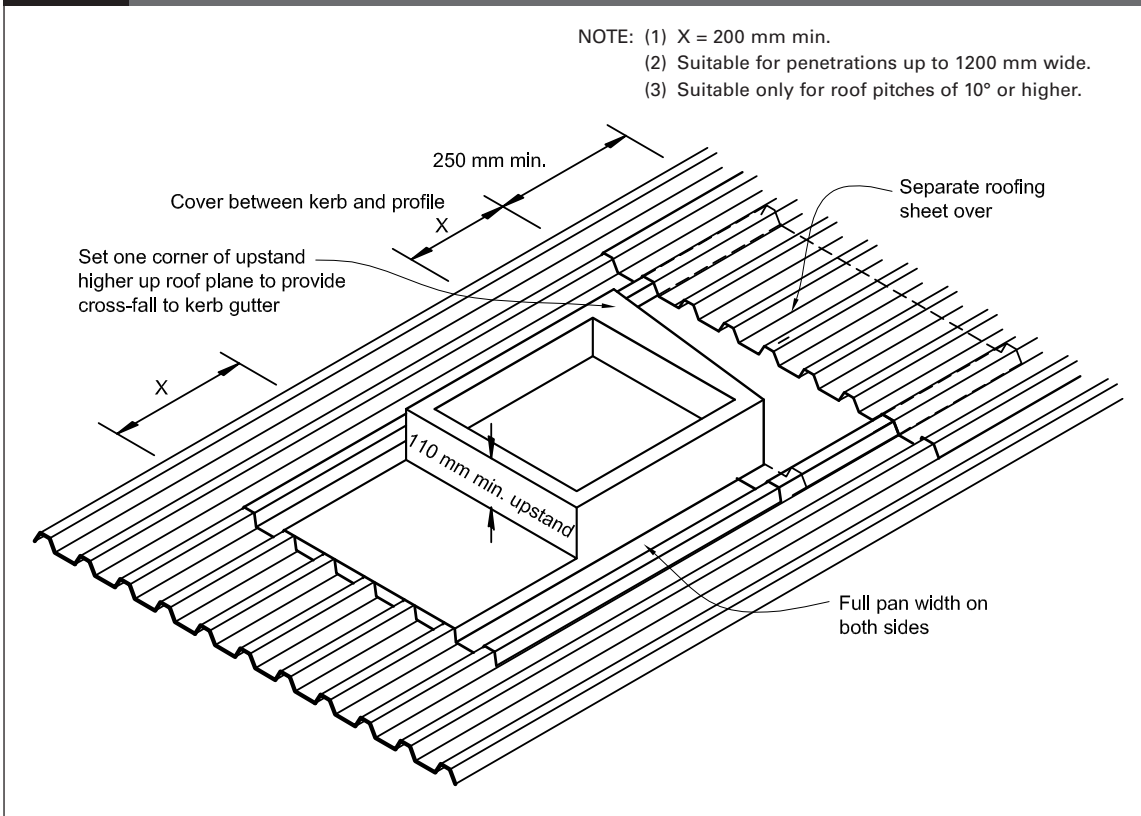
Amend 13  
Nov 2023

**Figure 6: Flashing for pipes, cables and other penetrations**  
 Paragraphs 5.2.4 and 5.2.5 a)

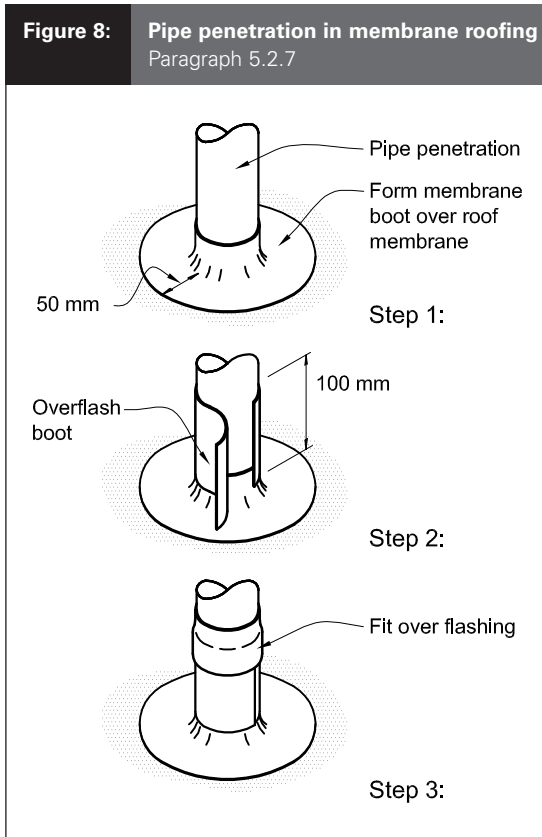


Amend 13  
 Nov 2023

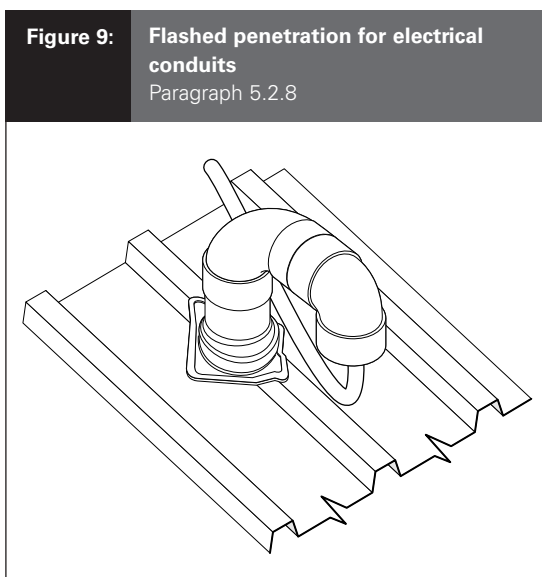
**Figure 7: Soaker flashings for penetrations (profiled metal roofs)**  
 Paragraph 5.2.5 b)



**5.2.7** Penetrations through *membrane* roofs must be as shown in Figure 8.



**5.2.8** One method of *flashing* penetrations through roofs for electrical conduits or fittings is shown in Figure 9.



The diameter of the conduit should be the minimum practicable diameter to suit the cable size and any electrical regulatory requirements.

**COMMENT:**

Alternatively, a nylon cable gland can be used on the flat part of a profiled metal roof which meets or exceeds IP55.

Other methods can also be used that meet the electrical regulatory requirements and are *weathertight*.

**5.2.9** Sealant used in the installation of solar *water heaters* must be a neutral cure silicone sealant and must be used in conjunction with mechanical fasteners. The sealant must comply with:

- a) Type F, Class 2OLM or 25LM of ISO 11600, or
- b) low modulus Type II Class A of Federal Specification TTS-00230C.

**5.2.10** Acetic cured silicone sealants may be used with stainless steel but must not be used on zinc or aluminium-zinc coatings.

**5.2.11** Sealants used on roof penetrations must not be used as the primary method of excluding the ingress of moisture. Joints must be designed to allow the discharge of water in the absence of any sealant.

**5.2.12** All fixings or penetrations through the roof must be through the crests of the roof *cladding*.

**5.3 Pipe installation**

**5.3.1** Pipes and their supports must be electrochemically compatible or be electrolytically separated (refer to Table 2).

**5.3.2** Pipes must be installed and supported to permit thermal movement, except where anchor points are necessary.

**5.3.3** Water supply pipe work must be supported at centres of no greater than those given in G12/AS1, Table 9: Water Supply Pipework Support Spacing.

**5.4 Pipe insulation**

**5.4.1** Hot water pipes must be insulated to satisfy the requirements of NZBC Clause H1.3.4, except where connected to a heat dissipation device.

Amend 13  
Nov 2023

**5.4.2** Where closed cell elastomeric pipe insulation is used outside the *building* envelope, it must be painted or have another form of protection to prevent rapid deterioration due to exposure to UV radiation. Pipe insulation must be protected and must have a *durability* of not less than 5 years.

**COMMENT**

One way to meet the hot water pipe insulation requirements referred to in Paragraph 5.4.1 is to comply with NZS 4305: 1996 Domestic type hot water systems.

**6.0 Structural Support for Solar Water Heaters**

**6.1 Scope**

**6.1.1** Paragraph 1.1.1 of this Acceptable Solution describes when these structural and fixing requirements can be used.

**6.2 General requirements**

**6.2.1** The installation of solar collectors on roofs must not produce restrictions to rainwater flow that could cause water to accumulate or pond.

**6.2.2** The installation of solar collectors must not dent, bend or distort the roof *cladding* or damage any protective coatings.

**6.2.3** All fixings that penetrate metal *cladding* must be provided with sealing washers or boots to prevent leakage in accordance with Paragraph 5.2.

**COMMENT:**

For additional guidance on selection and application of fastenings, refer to the roof *cladding* manufacturer.

**6.2.4** Solar collectors must be supported at no less than four points. The outermost support points must be within 200 mm of the outside edge of the solar collector.

**6.2.5** Roof framing must not be reduced in strength except for drilling for bolts or screws for attaching solar collectors.

**6.2.6** All screw and bolt fixings into roof *framing* timber must be installed with minimum distances from the centre of the fixing to the edge of the timber of:

- a) 20 mm for 8 gauge screws,
- b) 25 mm for 14 gauge screws,
- c) 40 mm for 10 mm bolts.

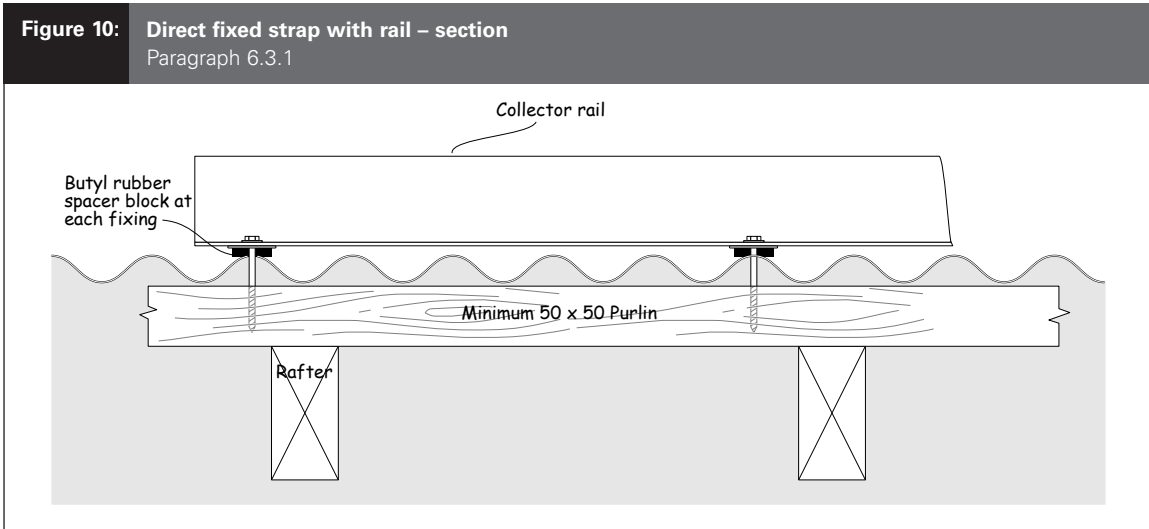
**6.2.7** The centre of all fixings must be no closer than 10 fixing diameters from the end of a piece of timber.

**COMMENT:**

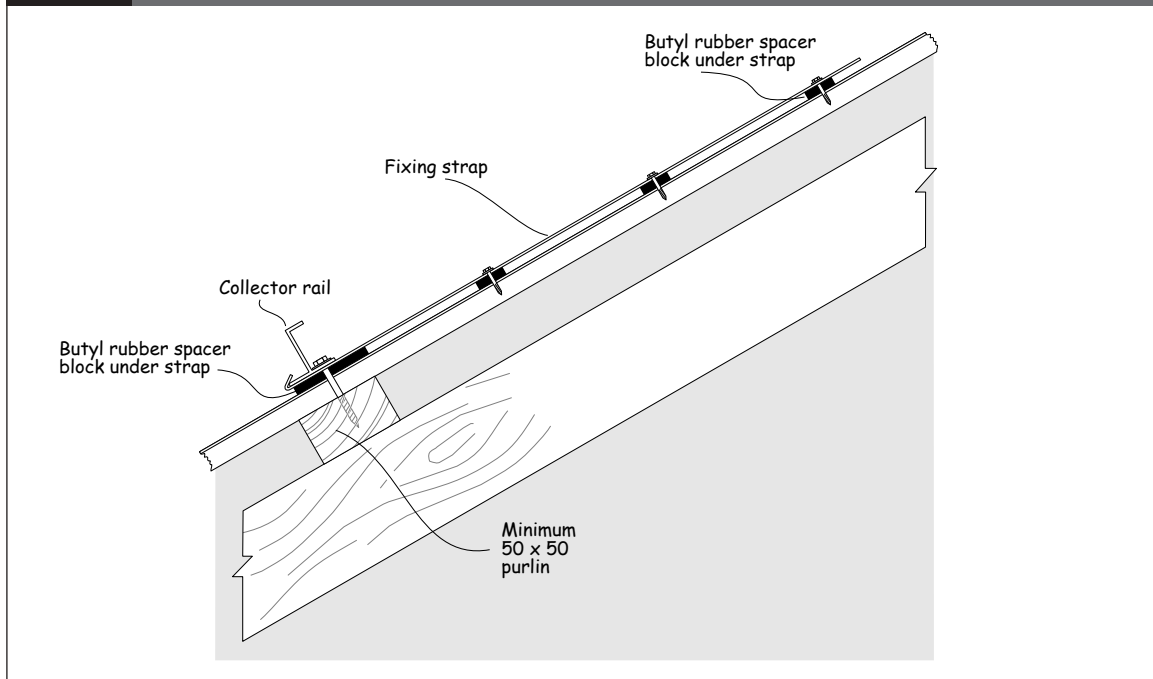
End and edge distances for fixings are in accordance with NZS 3603: 1993.

**6.3 Direct fixed solar collectors parallel to the roof**

**6.3.1** Solar collectors can be fixed directly to the roof as shown in Figures 10 and 11 or Figures 12 and 13, where the requirements described in Paragraph 6.3 are met.



**Figure 11:** Direct fixed strap with rail – elevation  
Paragraph 6.3.1



**6.3.2** Solar collectors mounted on the roof cladding must meet the materials requirements described in Paragraph 2.

**6.3.3** Solar collectors fixed directly to metal roof *cladding* must be:

- a) attached with 12 self-tapping 8 gauge (4 mm) metal screws fixed to metal roof *cladding* provided the weight of the solar collector is spread over a sufficient number of points of contact so that the average load on any one point is not more than 15 kg, and
- b) attached with 4 x 8 gauge (4 mm) screws into purlins 50 mm wide or larger within 200 mm of each of the four corners of the solar collector.

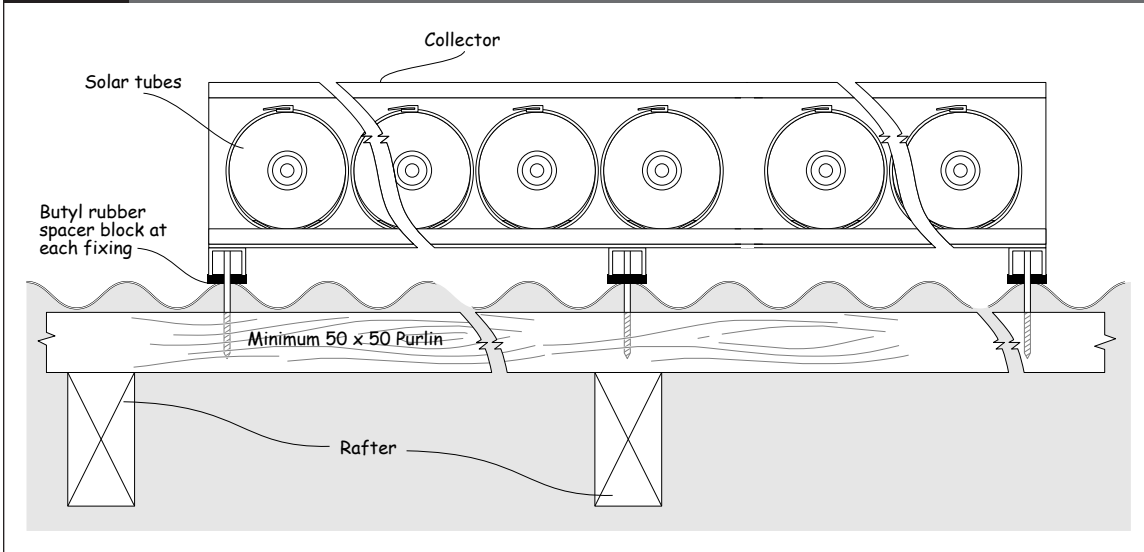
**6.3.4** Solar collectors can be installed on concrete or clay tiles with:

- a) stainless steel straps inserted through the joints between successive rows of tiles and screw fastened to *rafters*, truss top chords or *under-purlins* 75 x 45 mm or larger, and
- b) support within 100 mm of the centre of the underlying tile batten, and
- c) the load distributed across as many tiles as practicable.

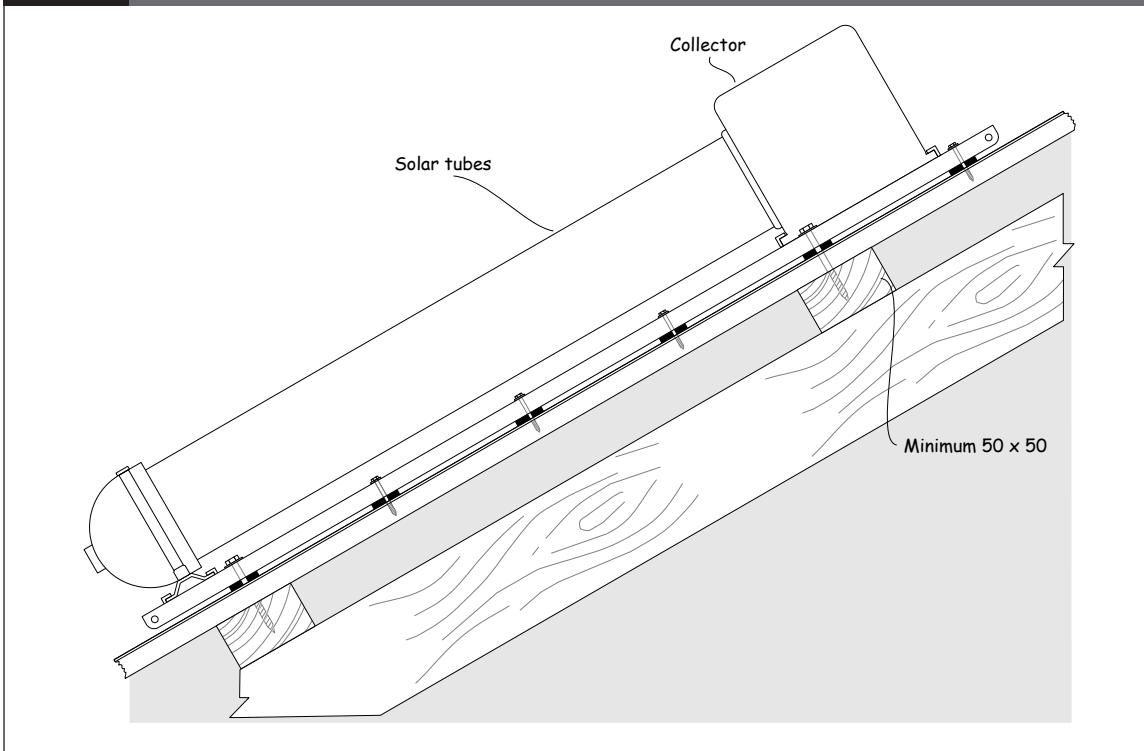
**COMMENT:**

1. *Cladding* materials which need regular washing may require solar collectors to be elevated above the roof *cladding*. Refer to your roof cladding manufacturer for specific advice. Elevated options are provided in Paragraphs 6.4 to 6.6.
2. The susceptibility for concrete and clay tiles to breakage means that special care must be taken when working on and attaching systems to these roofs.
3. Solar *water heater* manufacturers and installers have developed proprietary mounting systems which may have equivalent performance to this Acceptable Solution.

**Figure 12: Direct fixed channel – section**  
Paragraph 6.3.1



**Figure 13: Direct fixed channel – elevation**  
Paragraph 6.3.1



## 6.4 Elevated solar collector panels parallel to the roof

**6.4.1** Solar collectors mounted parallel to the roof that are elevated up to 50 mm above the roof *cladding* must be fixed:

- a) as shown in Figure 14, with 14 gauge screws into one of the following:
  - i) *purlins* 70 x 45 mm or larger on their flat, that span no more than 700 mm, or
  - ii) *purlins* 90 x 45 mm or larger on their flat, that span no more than 900 mm, or
  - iii) *rafters* 90 x 45 mm or larger, or
  - iv) truss top chords 90 x 45 mm or larger, or
- b) as shown in Figure 15, with 10 mm hot dip galvanised bolts to *purlins* 90 x 45 mm or larger that span no more than 900 mm, or

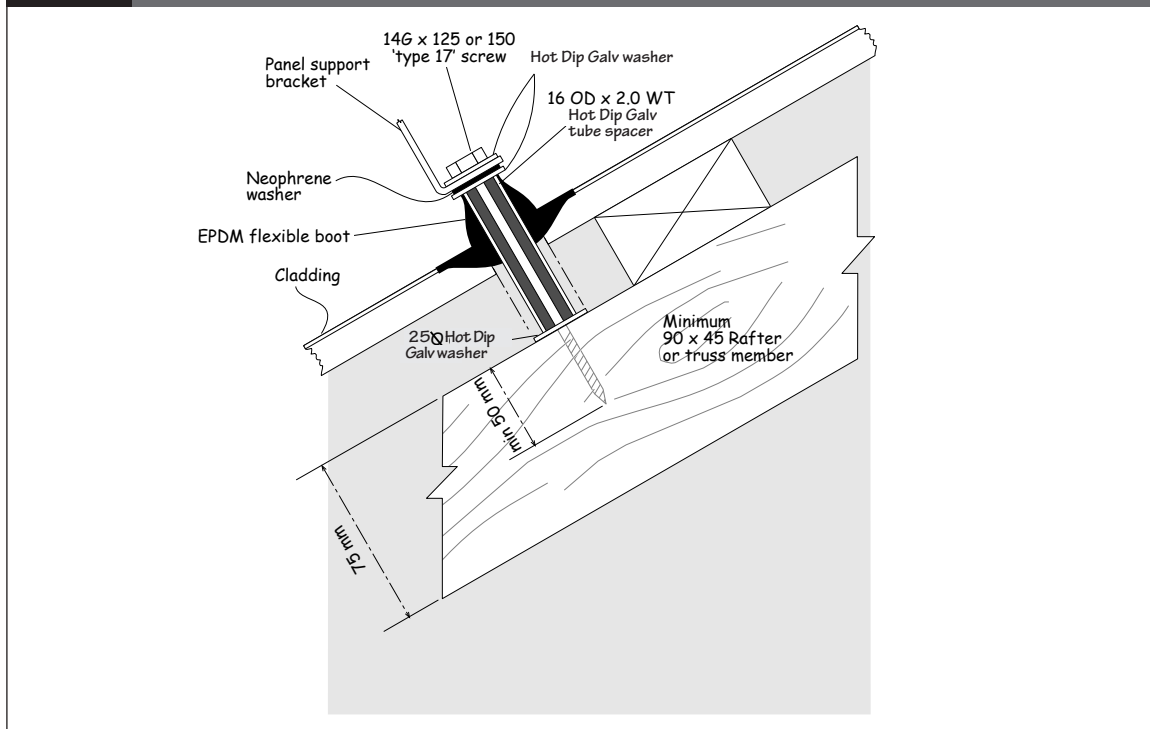
c) as shown in Figure 16, with 12 mm bolts welded to 3 mm plate, hot dip galvanised after welding and screw fixed to either:

- i) *rafters*, or
- ii) truss top chords.

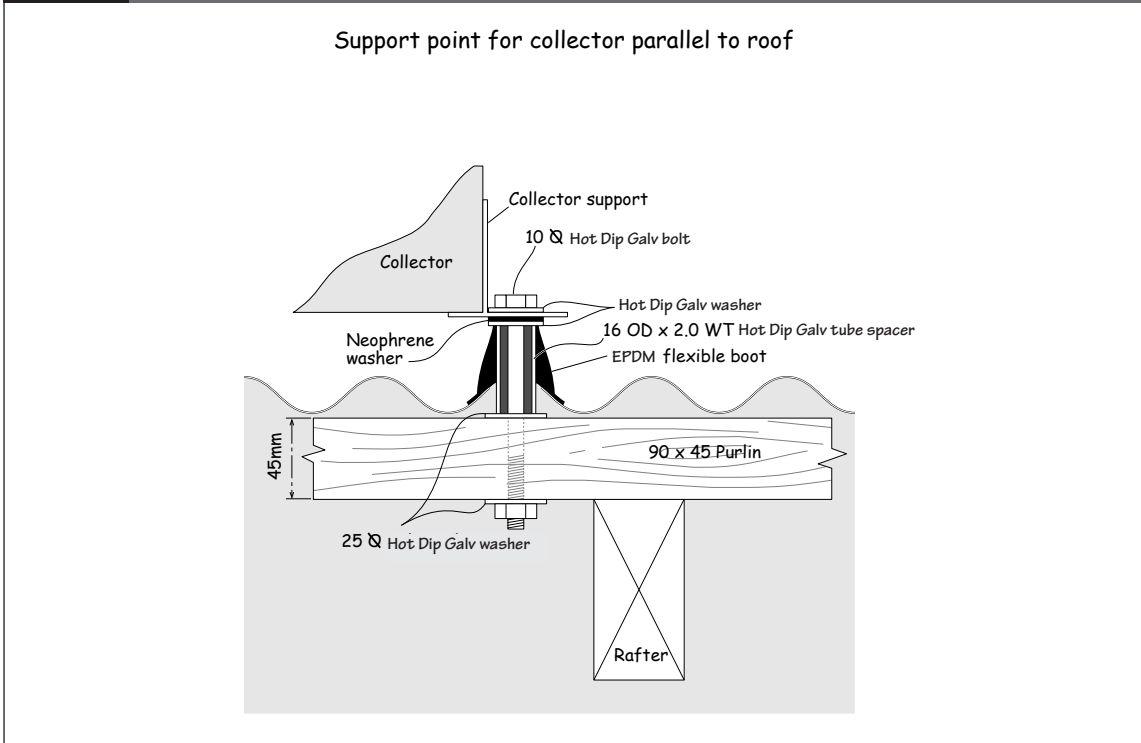
**6.4.2** Solar collectors mounted parallel to the roof that are elevated up to 50 mm above the roof *cladding* must be supported by:

- a) underlying *purlins* conforming to Paragraph 6.4.1 (a) or (b), or
- b) underlying *rafters* or trusses with connections conforming with Paragraphs 6.4.1 (a) or (c), or
- c) collector support rails conforming to Paragraph 6.5.

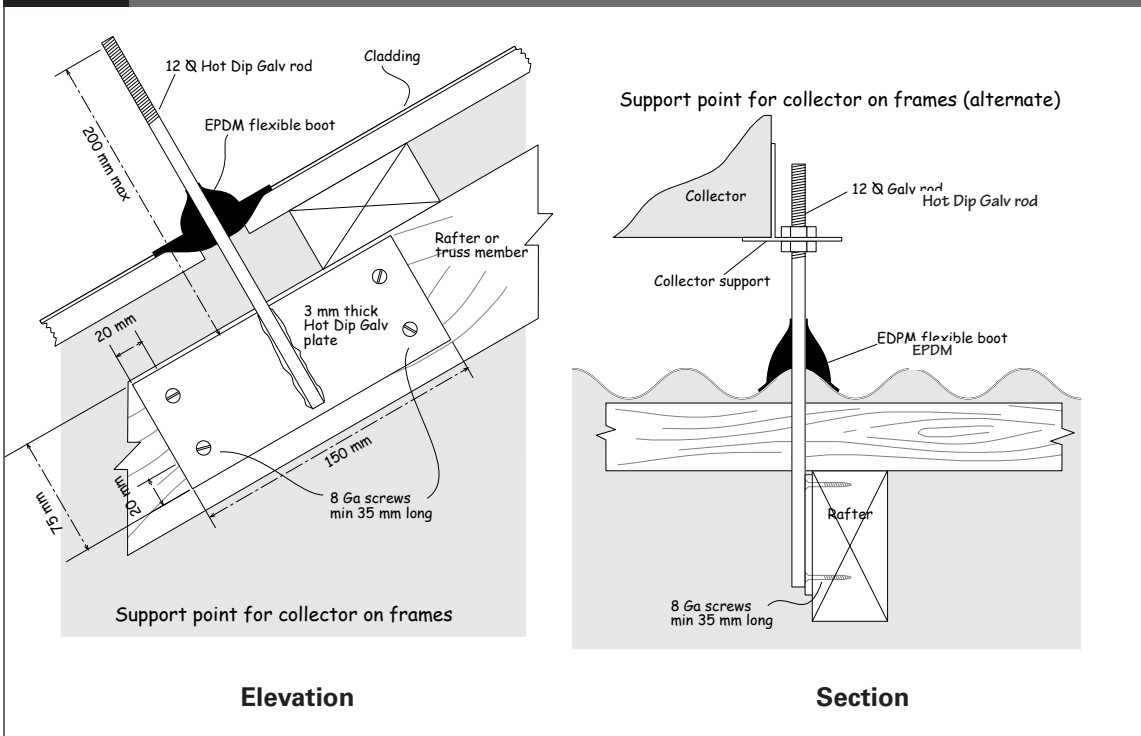
**Figure 14:** Screw fixing  
Paragraph 6.4.1 b)



**Figure 15:** Bolt fixing  
Paragraph 6.4.1 a)

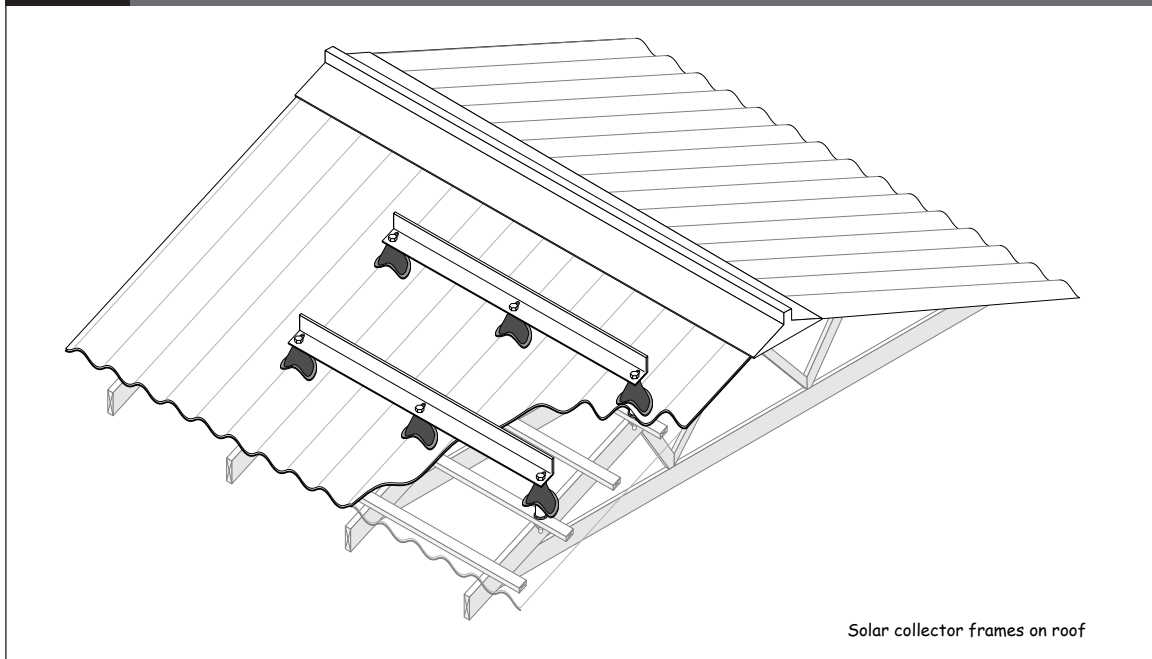


**Figure 16:** Stud fixing  
Paragraph 6.4.1 c)

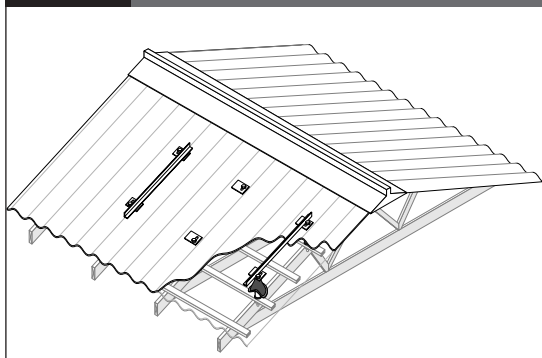




**Figure 17:** Collector support rails across roof slope  
Paragraph 6.5.1 a)



**Figure 18:** Collector frame up slope of roof  
Paragraph 6.5.1 b)



## 6.5 Collector support rails

**6.5.1** Collector support rails may either:

- a) run horizontally across the slope of the roof as provided for in Paragraph 6.5.2 and Figure 17, or
- b) run up the slope of the roof as provided for in Paragraph 6.5.3 and Figure 18.

**6.5.2** Collector support rails running horizontally across the roof slope, as shown in Figure 17, must be in one piece and span

each space between *rafters* or trusses that have a solar collector above them. Rails may cantilever up to 200 mm beyond a rafter or truss. The collector support rails are to be fixed to either:

- a) each *rafter* or truss that they cross using the details given in Figures 14 and 16, or
- b) *purlins*, provided the *purlins* are a minimum size of 90 x 45 mm on their flat and span a maximum of 900 mm using the details given in Figures 14 and 15.

**6.5.3** Collectors laid on support rails running up the slope of the roof must be in one piece and be supported as shown in Figure 18 by either:

- a) each *purlin* that is crossed of a minimum size of 90 x 45 mm on their flat which spans a maximum of 950 mm using the connection details given by Figure 14, or
- b) *rafters* or truss top chords at not more than 1500 mm centres and within 300 mm of each end of the collector support rails using the connection details given by Figure 14 or 16.

## 6.6 Mounting collectors at a different pitch to the roof cladding

**6.6.1** Solar collectors mounted at a different pitch to the pitch of the roof must be installed with no less than 8 fixing points and must meet all the requirements described in Paragraph 6.6 and Figure 19.

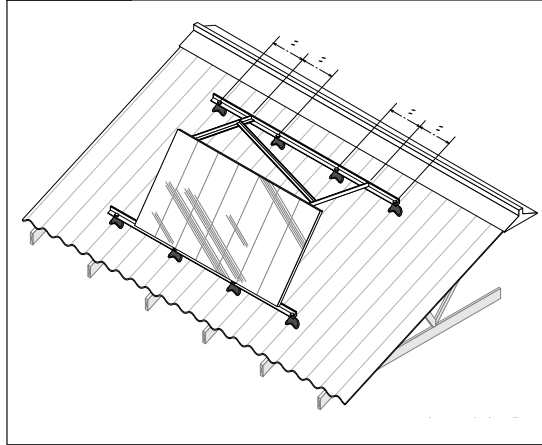
**6.6.2** Solar collectors must be mounted on support rails running horizontally across the roof slope that comply with Paragraph 6.5.2 except for the following differences:

- they must be supported by four *rafters* or truss top chords, and
- they must be hot dip galvanised mild steel or stainless steel angles with a minimum section modulus about axes parallel to the sides of the angle of  $3.3 \text{ cm}^3 \times 10 \text{ mm}^3$ , and
- they must be connected to the *rafters* or truss top chords with fixings as shown in Figure 20, and
- the connections between the struts and the collector support rails must be mid-way between the outer pair of collector support rail fixings.

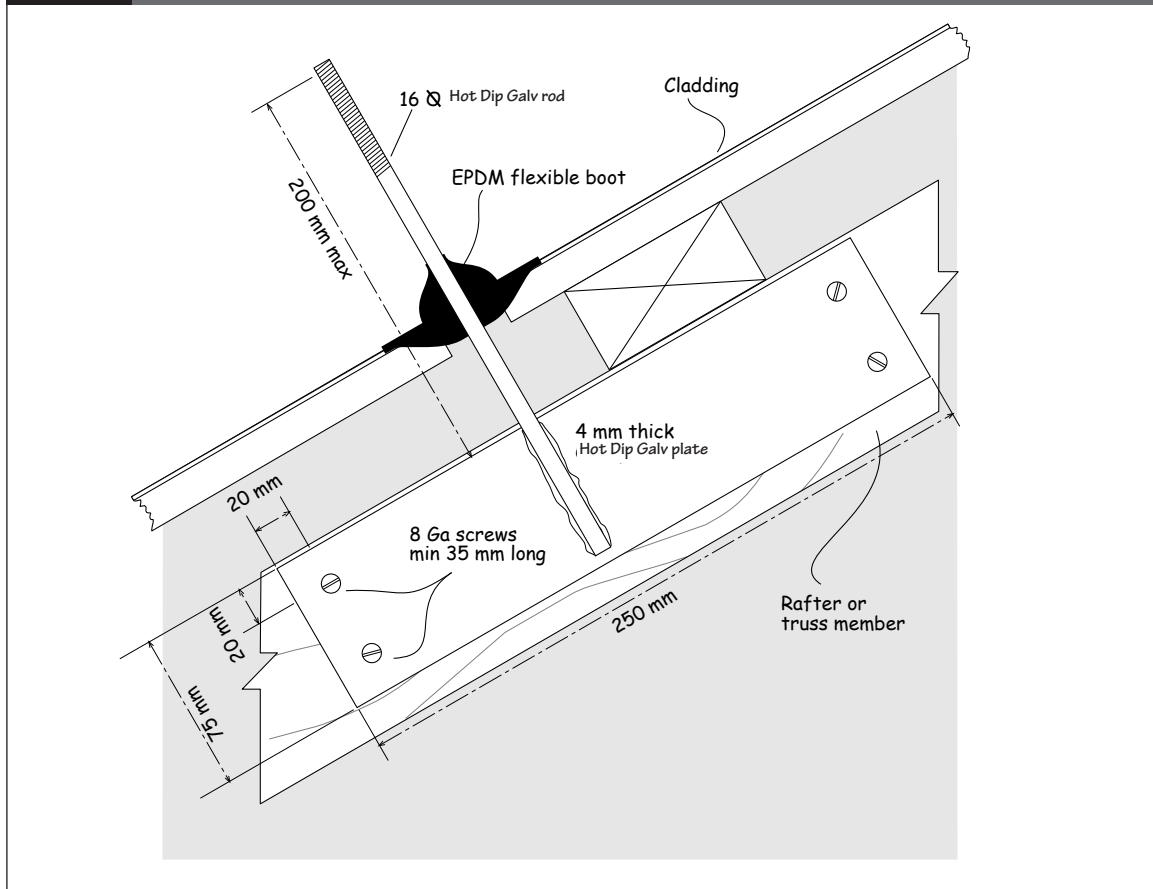
### COMMENT:

- A steel angle section  $50 \times 50 \times 6 \text{ mm}$  meets the minimum strength requirements of Paragraph 6.6.2.
- Other materials can be used for the support rails which meet the materials requirements described in Paragraph 2.0 and have equivalent strength to the rails described in Paragraph 6.6.2 b).

**Figure 19:** Collector at different pitch to roof  
Paragraph 6.6.1



**Figure 20:** Stud fixing for panels at different pitch  
Paragraph 6.6.2 c)



**6.6.3** The edge of the panel elevated above the roof plane is to be supported by hot dip galvanized steel or stainless steel angle struts which are:

- 25 x 25 x 3 mm angle for struts up to 1.0 m long
- 30 x 30 x 3 mm angle for struts up to 1.4 m long, or
- 40 x 40 x 3 mm angle for struts up to 2.4 m long.

Cuts or holes made in steel after galvanizing are to be protected from corrosion.

**6.6.4** A diagonal is to run from within 50 mm of the top of one strut to within 50 mm of the bottom of the other strut. It must be the same size as the struts.

**6.6.5** Connections between the struts, the diagonal and support rails are to be:

- for hot dip galvanized steel, one M8 hot dip galvanized Class 4.8 bolt with nut and washers at each intersection, or
- for stainless steel, one M8 stainless steel bolt with nut and washers at each intersection, or
- fully welded – any mild steel that is welded must be hot dip galvanized after welding.

**6.6.6** Connections between the upper ends of the struts and the collector must be of equivalent strength to the those of Paragraph 6.6.5

**6.6.7** Alternatively, proprietary elevated frames can be used which:

- a) meet the requirements described in Paragraphs 6.6.1 and 6.6.2
- b) are subject to specific engineering design
- c) result in the load on each collector support rail being evenly distributed over each of the four fixing points.

## 7.0 Maintenance and Durability

### 7.1 Maintenance

**7.1.1** A permanent label must be fixed to a prominent part of the system which includes all markings required in the appropriate Standard identified in Paragraph 3.1.1.

#### COMMENT

1. Solar *water heaters* should be installed so that they can be easily maintained and owners should be provided with adequate instructions on the maintenance requirements.
2. Maintenance should be carried out to achieve the required:
  - a) system performance, and
  - b) *durability* of the solar *water heater* and any affected *building* components and junctions.
3. The maintenance required is dependent on the:
  - a) type of solar *water heater*,
  - b) materials and components used in the system manufacture and installation,
  - c) manufacturer's recommendations,
  - d) position of the solar *water heater* on the *building*,
  - e) geographical location and specific site conditions.

#### COMMENT:

Washing by rain removes most accumulated atmospheric contaminants from roof *cladding*, but sheltered areas below solar collectors may be protected from the direct effects of rain and therefore may require regular manual washing. High pressure water must not be directed at sensitive junctions such as penetrations and other *flashings*. Care must be taken to avoid water being driven past anti-capillary gaps and *flashings*.

## 7.2 Durability

**7.2.1** Solar *water heaters* and their components must meet the *durability* requirements specified in NZBC Clause B2.

**7.2.2** A solar *water heater* is easy to access and moderately difficult to replace and therefore the *durability* requirement is 15 years.

**7.2.3** Some components of the system will require maintenance and/or replacement. Components requiring maintenance or replacement before 15 years must be clearly identified in the owner's manual.

#### COMMENT:

NZS 4613:1986 states that:

"All materials used in the construction of solar equipment must have an expected in-service life of at least 15 years unless specifically excluded by the manufacturer" (Clause 103.2), and

"Collectors must have an expected service life of at least 15 years with no loss of fitness for purpose or rapid degradation during this period" (Clause 104.1).

NZS 4613: 1986 has been incorporated by reference in the Acceptable Solutions for G12 since October 2001.

Amend 9  
Feb 2014

# Acceptable Solution G12/AS3

## 1.0 AS/NZS 3500.1 and AS/NZS 3500.4

---

**1.0.1** AS/NZS 3500.1 and AS/NZS 3500.4 are Acceptable Solutions as modified by Paragraphs 1.0.3 and 1.0.4, for the design and installation of cold and heated *water supply systems*.

**1.0.2** Buildings having the classification of Community Care (e.g. hospitals, old people's homes, prisons) to which this Acceptable Solution is applied shall be provided with cold water storage of no less than 50 litres per person in accordance with the requirements of Acceptable Solution G12/AS1 Paragraph 5.1.1 Water storage.

**COMMENT:**

Community Care is a classified use defined in Clause A1 of the Building Code.

**1.0.3 Modifications to AS/NZS 3500.1**

**Clause 2.2** Delete and replace with "Materials and products shall comply with NZBC Clause B2 Durability, and G12/AS1 Paragraph 2.0 Materials".

**Clause 4.2.5** Delete Clause

**1.0.4 Modifications to AS/NZS 3500.4**

**Clause 2.2** Delete and replace with "Materials and products shall comply with NZBC Clause B2 Durability, and G12/AS1 Paragraph 2.0 Materials".

Amend 13  
Nov 2023

64B

# Index G12/VM1 & AS1/AS2/AS3

All references to Verification Methods and Acceptable Solutions are preceded by **VM** or **AS** respectively.

<b>Backflow protection</b> .....	<b>AS1</b> 3.4
air gaps .....	<b>AS1</b> 3.6
backflow prevention devices .....	<b>AS1</b> 3.7
atmospheric vacuum breakers .....	<b>AS1</b> 3.7.4, 3.8.1, 3.8.2, Table 2
double check valves .....	<b>AS1</b> 3.7.4, 3.8.1, 3.8.2, Table 2
pressure vacuum breakers .....	<b>AS1</b> 3.7.4, 3.8.1, 3.8.2, Table 2
reduced pressure zone devices .....	<b>AS1</b> 3.7.4, 3.8.1, 3.8.2, Table 2, Table 2A
containment protection .....	<b>AS1</b> 3.5, Table 2A
installation .....	<b>AS1</b> 3.7.3, 3.7.4, 3.8.1
testing .....	<b>AS1</b> 3.8
<b>Cold water expansion valves</b>	
(expansion control valves) .....	<b>AS1</b> 6.3.3, 6.6.2, 6.6.3, Figures 8 to 10, Table 6
installation .....	<b>AS1</b> 6.6.5
relief valve drains .....	<b>AS1</b> 6.7, Figures 8 to 10, and 13
<b>Cross connections</b> .....	<b>AS1</b> 3.1,
hazard .....	<b>AS1</b> 3.3
<b>Energy cut-offs</b> .....	<b>AS1</b> 6.4.1 c), 6.5.2
<b>Equipotential bonding</b> .....	<b>AS1</b> 9.0
earth bonding conductors .....	<b>AS1</b> 9.3
installation of conductors .....	<b>AS1</b> 9.2
metallic sanitary fixtures .....	<b>AS1</b> 9.2.2, Figure 20
metallic water supply pipes .....	<b>AS1</b> 7.2.1, Figure 19
<b>Expansion vessels</b> .....	<b>AS1</b> 6.6.7, 6.6.8, Figure 8A
<b>Filters</b> .....	see Strainers
<b>Hot water supply</b> .....	<b>AS1</b> 6.0
pipe sizes .....	<b>AS1</b> 6.12, Table 4
<b>Identification of non-potable water supply</b> .....	<b>AS1</b> 4.2.1
<b>Isolating valves</b> .....	<b>AS1</b> 3.7.1, 5.4.2
<b>Legionella bacteria</b> .....	<b>AS1</b> 6.14.3
<b>Mixing devices</b>	
tempering valves .....	<b>AS1</b> 6.14.2, Figure 16
<b>Non-potable water supply</b> .....	<b>AS1</b> 4.1
outlet identification .....	<b>AS1</b> 4.2.1, Figure 3
<b>Non-return valves</b> .....	<b>AS1</b> Figures 7 to 10, Table 6
<b>Operating device</b> .....	6.3

**People with disabilities** ..... **AS1** 8.0  
 usable water taps ..... **AS1** Figure 18

**Potable water supply** ..... **AS1** 3.0, 4.0

**Pressure limiting valves** ..... **AS1** 5.3.2, 5.3.3, 6.2.1, Figure 8(a),  
 Figure 8(b), Table 6

**Pressure reducing valves** ..... **AS1** 5.3.2, 5.3.3, 6.2.1,  
 Figures 7 and 9, Table 6

**Pressure relief valves** ..... **AS1** 6.4.1, 6.4.2, 6.6, Table 6  
 installation ..... **AS1** 6.6.5  
 relief valve drains ..... **AS1** 6.7, Figures 12 and 13

**Relief valve drains** ..... see Cold water expansion valves,  
 Temperature relief valves and  
 Temperature/pressure relief valves

**Safe trays** ..... **AS1** 5.2.3, 6.11.3

**Safe water temperatures** ..... **AS1** 6.14

**Safety device** ..... **AS1** 6.4

**Sanitary appliances** ..... **AS1** 8.0.1, Table 1

**Sanitary fixtures** ..... **AS1** 6.12.1, 6.14.2, Figure 20, Tables 1 and 3

**Solar water heaters**  
 Installation ..... **AS2** 5.0  
 Pipe installation ..... **AS2** 5.3  
 Pipe insulation ..... **AS2** 5.4  
 Weathertightness ..... **AS2** 5.2, Table 4, Figures 2–9  
 Wetback water heaters ..... **AS2** 5.1  
 Location ..... **AS2** 4.0, 4.1  
 Solar orientation and inclination ..... **AS2** 4.2, Figure 2  
 Maintenance and durability ..... **AS2** 7.0  
 Durability ..... **AS2** 7.2  
 Maintenance ..... **AS2** 7.1  
 Materials ..... **AS2** 2.0  
 Material selection ..... **AS2** 2.1, Tables 1, 2 and 3  
 Requirements ..... **AS2** 3.0  
 Operating and safety devices ..... **AS2** 3.4  
 Protection from frosts ..... **AS2** 3.6, Figure 1  
 Protection from Legionella bacteria ..... **AS2** 3.5  
 Sizing of systems ..... **AS2** 3.3  
 Solar controller ..... **AS2** 3.2  
 Solar water heaters and components ..... **AS2** 3.1.1  
 Scope ..... **AS2** 1.0  
 Exclusions ..... **AS2** 1.2  
 Structural support limitations ..... **AS2** 1.1

Amend 13  
 Nov 2023

Amend 13  
 Nov 2023



Structural support . . . . . **AS2** 6.0  
 Collector support rails . . . . . **AS2** 6.5, Figures 17 and 18  
 Elevated solar collectors parallel to the roof . . . . . **AS2** 6.4  
 Figures 14–16  
 General requirements . . . . . **AS2** 6.2, Figures 10–13  
 Mounting collectors at different pitch to roof cladding . . **AS2** 6.6,  
 Figures 19 and 20  
 Scope . . . . . **AS2** 6.1

**Storage water heaters** . . . . . **AS1** 6.2, 6.3.1, 6.6.3, 6.6.5,  
 6.7.2, 6.8 to 6.11, Table 5  
 drain pipes . . . . . **AS1** 4.10.3  
 open vented . . . . . **AS1** 6.3.2, Figures 6 and 7  
 free outlet type . . . . . **AS1** 6.1.2, 6.4.2  
 mains pressure supply. **AS1** 6.2.1 Figure 8(a), Figure 8(b), Table 5  
 tank supply. . . . . **AS1** 6.1.1, Figure 6, Table 5  
 seismic restraint . . . . . **AS1** 6.11.5, Figure 4  
 unvented . . . . . see Storage water heaters, valve vented  
 valve vented . . . . . **AS1** 6.3 to 6.7, Figure 8

**Strainers** . . . . . **AS1** 6.2.1

**Temperature control devices** . . . . . **AS1** 6.14.2 Table 8A,  
 Table 8B, Figure 16

**Temperature/pressure relief valves** . . . . . **AS1** 6.4.1, Figure 8(a),  
 Figure 8(b), Table 6  
 installation . . . . . **AS1** 6.6.5  
 relief valve drains . . . . . **AS1** 6.7, Figures 12 and 13

**Thermostats** . . . . . **AS1** 6.3.5, 6.5.1

**Vacuum relief valves** . . . . . **AS1** Table 6

**Vent pipes** . . . . . **AS1** 6.3.2, 6.8  
 diameter . . . . . **AS1** 6.8.2 b)  
 height . . . . . **AS1** 6.8.2 d)  
 installation . . . . . **AS1** 6.9.1  
 insulation . . . . . **AS1** 6.8.3  
 termination . . . . . **AS1** 6.8.2 c)

**Verification Method** . . . . . **VM1** 1.0

**Water heaters** . . . . . **AS1** 6.1, Table 5  
 installation . . . . . **AS1** 6.11  
 instantaneous water heaters. . . . . **AS1** 6.1.1, Table 5  
 storage water heaters. . . . . see Storage water heaters  
 wet-back water heaters . . . . . **AS1** 6.13, Figure 15

**Water main** . . . . . **AS1** 3.1.1, 3.2.1 b), 3.5.1, 5.1.1

Amend 13  
Nov 2023

Amend 13  
Nov 2023

Amend 13  
Nov 2023

**Water supply systems** . . . . . **VM1 1.0, AS1 5.0**

flushing . . . . . **AS1 7.7**

Amend 13 | installation . . . . . **AS1 7.5**  
Nov 2023 |

anchor points . . . . . **AS1 7.1.2**

Amend 13 | electrochemical compatibility . . . . . **AS1 7.1.1**  
Nov 2023 |

in concrete or masonry . . . . . **AS1 7.4.3**

pipe supports . . . . . **AS1 7.1**

spacing . . . . . **AS1 7.1.3, Table 9**

Amend 13 | pipes below ground . . . . . **AS1 7.4.2**  
Nov 2023 |

protection from damage . . . . . **AS1 7.4**

protection from freezing . . . . . **AS1 7.2**

protection from frosts . . . . . **AS1 3.6.3**

Amend 13 | unintentional heating . . . . . **AS1 7.3**  
Nov 2023 |

maintenance facilities . . . . . **AS1 5.5**

materials . . . . . **AS1 2.0, Table 1**

pressure limitations . . . . . **AS1 2.2.2 a)**

temperature limitations . . . . . **AS1 2.2.2 a)**

pipe size . . . . . **AS1 5.4, Table 4**

flow rates . . . . . **AS1 5.4.1, Table 3**

pressures . . . . . **AS1 5.3**

watertightness . . . . . **AS1 7.6**

Amend 13 | unintentional heating . . . . . **AS1 7.3.1**  
Nov 2023 |

**Water tanks** . . . . . **AS1 5.2, 6.2.1**

access . . . . . **AS1 5.2.5, Figure 4**

covers . . . . . **AS1 5.2.4**

Amend 13 | disinfection . . . . . **AS1 5.1.2**  
Nov 2023 |

location . . . . . **AS1 5.2.1**

overflow pipes . . . . . **AS1 5.2.2, Figure 4**

safe trays . . . . . **AS1 5.2.3, Figure 4**

seismic restraint . . . . . **AS1 5.2.7, Figure 4**

structural support . . . . . **AS1 5.2.7, Figure 4**

water storage tanks . . . . . **AS1 5.1**