



MINISTRY OF BUSINESS,  
INNOVATION & EMPLOYMENT  
HĪKINA WHAKATUTUKI

# Acceptable Solutions and Verification Methods

For New Zealand Building Code Clause  
**E1 Surface Water**



## Status of Verification Methods and Acceptable Solutions

Verification Methods and Acceptable Solutions are prepared by the Ministry of Business, Innovation and Employment in accordance with section 22 of the Building Act 2004. Verification Methods and Acceptable Solutions are for use in establishing compliance with the New Zealand Building Code.

A person who complies with a Verification Method or Acceptable Solution will be treated as having complied with the provisions of the Building Code to which the Verification Method or Acceptable Solution relates. However, using a Verification Method or Acceptable Solution is only one method of complying with the Building Code. There may be alternative ways to comply.

Users should make themselves familiar with the preface to the New Zealand Building Code Handbook, which describes the status of Verification Methods and Acceptable Solutions and explains alternative methods of achieving compliance.

Defined words (italicised in the text) and classified uses are explained in Clauses A1 and A2 of the Building Code and in the Definitions at the start of this document.

Enquiries about the content of this document should be directed to:



**MINISTRY OF BUSINESS,  
INNOVATION & EMPLOYMENT**  
HĪKINA WHAKATUTUKI

Ministry of Business, Innovation and Employment  
PO Box 1473, Wellington 6140  
Telephone 0800 242 243  
Email: [info@building.govt.nz](mailto:info@building.govt.nz)

**Verification Methods and Acceptable Solutions  
are available from [www.building.govt.nz](http://www.building.govt.nz)**



**Te Kāwanatanga o Aotearoa**  
New Zealand Government

© Ministry of Business, Innovation and Employment 2023

This document is protected by Crown copyright, unless indicated otherwise. The Ministry of Business, Innovation and Employment administers the copyright in this document. You may use and reproduce this document for your personal use or for the purposes of your business provided you reproduce the document accurately and not in an inappropriate or misleading context. You may not distribute this document to others or reproduce it for sale or profit.

The Ministry of Business, Innovation and Employment owns or has licences to use all images and trademarks in this document. You must not use or reproduce images and trademarks featured in this document for any purpose (except as part of an accurate reproduction of this document) unless you first obtain the written permission of the Ministry of Business, Innovation and Employment.

## Document Status

The most recent version of this document (Amendment 12), as detailed in the Document History, is approved by the Chief Executive of the Ministry of Business, Innovation and Employment. It is effective on 2 November 2023 and supersedes all previous versions of this document.

The previous version of this document (Amendment 11) will cease to have effect on 1 November 2024.

People using this document should check for amendments on a regular basis. The Ministry of Business, Innovation and Employment may amend any part of any Verification Method or Acceptable Solution at any time. Up-to-date versions of Verification Methods and Acceptable Solutions are available from [www.building.govt.nz](http://www.building.govt.nz)

<b>E1: Document History</b>			
	<b>Date</b>	<b>Alterations</b>	
First published	July 1992		
Amendment 1	September 1993	pp. vi and vii, References p. 14, 3.2.1, Figure 3 p. 16, Table 2 p. 18, 3.7.4 p. 20, Figure 13	p. 21, Figure 14 p. 22, Table 4, Table 5, 5.1, 5.1.1, 5.1.2 p. 23, Figure 15, Figure 16 p. 24, 5.1.3, 5.1.4
Amendment 2	19 August 1994	pp. i and ii, Document History p. vi, NZS 3441 replaced NZS 3403	p. 21, 3.9.8 p. 22, Table 4, Table 5 p. 24, 5.1.3, Table 6
Reprinted incorporating Amendments 1 and 2 – October 1994			
Amendment 3	1 December 1995	p. ii, Document History	p. iii, E1.3.1
Reprinted incorporating Amendments 1, 2 and 3 – July 1996			
Amendment 4	1 December 2000	p. ii, Document History p. v, Contents pp. vi and vii, References	p. viii, Definitions pp. 1 – 12K, Revised VM1 pp. 27 and 28, Index
Amendment 5		p. 2, Document History, Status p. 7, References p. 31, 9.0.5	p. 39, 3.8.1 p. 42, 4.3.2
Amendment 6	6 January 2002	p. 3 Code Clause E1	
Reprinted incorporating Amendments 4, 5 and 6 – September 2003			
Amendment 7	Published 30 June 2010 Effective from 30 September 2010	p. 2, Document History, Status pp. 7 and 8, References pp. 9 and 10, Definitions p. 34, E1/AS1 Table 1 p. 37, E1/AS1 Table 3	p. 41, E1/AS1 3.9.8 p. 42, E1/AS1 Table 4 p. 44, E1/AS1 Table 6 p. 47, Index
Reprinted incorporating Amendment 7 – 30 September 2010			
Erratum 1	30 September 2010		p. 43, Figure 16
Amendment 8	Effective from 10 October 2011 until 14 August 2014	p. 2, Document History, Status pp. 7 and 8, References p. 9, Definitions	p. 34, E1/AS1 Table 1 p. 37, E1/AS1 Table 3 p. 42, E1/AS1 Table 4
Amendment 9	14 February 2014 until 30 May 2017	p. 2A Document History, Status p. 7 References p. 9 Definitions	p. 41, E1/AS1 3.9.7 p. 44, E1/AS1 5.5.2

**E1: Document History (continued)**

	<b>Date</b>	<b>Alterations</b>	
Amendment 10	Effective 1 January 2017 until 3 November 2021	pp. 7, 8 References p. 12 E1/VM1 Table 1	p. 31 E1/VM1 9.0.6
Amendment 11	Effective from 5 November 2020 until 1 November 2024	p. 5 Contents pp. 7–8 References p. 9 Definitions p. 13 E1/VM1 2.2.1 p. 34 E1/AS1 3.2.2, Table 1 p. 37 E1/AS1 3.6.1	p. 40 E1/AS1 Figure 13 p. 44 E1/AS1 5.1.5, Table 6 pp. 45–51 E1/AS1 Appendix A pp. 52–55 New Acceptable Solution E1/AS2 included p. 57 Index
Amendment 12	Effective on 2 November 2023	p. 5 Contents pp. 7–8a References p. 12 E1/VM1 2.1.1 p. 15 E1/VM1 Figure 3 p. 37 E1/AS1 3.6.2	p. 39 E1/AS1 3.9.2 p. 42 E1/AS1 Table 4 p. 44 E1/AS1 Table 6 pp. 52–53 E1/AS2 1.0.4

**Note:** Page numbers relate to the document at the time of Amendment and may not match page numbers in current document.

# New Zealand Building Code

## Clause E1 Surface Water

Amend 6  
Jan 2002

The mandatory provisions for building work are contained in the New Zealand Building Code (NZBC), which comprises the First Schedule to the Building Regulations 1992. The relevant NZBC Clause for Surface Water is E1.

### FIRST SCHEDULE—*continued*

#### Clause E1—SURFACE WATER

##### Provisions

##### OBJECTIVE

**E1.1** The objective of this provision is to:

- (a) Safeguard people from injury or illness, and *other property* from damage, caused by *surface water*, and
- (b) Protect the *outfalls* of drainage systems.

##### FUNCTIONAL REQUIREMENT

**E1.2** *Buildings* and *sitework* shall be constructed in a way that protects people and *other property* from the adverse effects of *surface water*.

##### PERFORMANCE

**E1.3.1** Except as otherwise required under the Resource Management Act 1991 for the protection of *other property*, *surface water*, resulting from an event having a 10% probability of occurring annually and which is collected or concentrated by *buildings* or *sitework*, shall be disposed of in a way that avoids the likelihood of damage or nuisance to *other property*.

**E1.3.2** *Surface water*, resulting from an event having a 2% probability of occurring annually, shall not enter *buildings*.

**E1.3.3** Drainage systems for the disposal of *surface water* shall be constructed to:

- (a) Convey *surface water* to an appropriate *outfall* using gravity flow where possible,
- (b) Avoid the likelihood of blockages,
- (c) Avoid the likelihood of leakage, penetration by roots, or the entry of ground water where pipes or lined channels are used,

Performance E1.3.2 shall apply only to *Housing*, *Communal Residential* and *Communal Non-residential buildings*.

Amend 6  
Jan 2002

Amend 6  
Jan 2002

1992/150	<i>Building Regulations 1992</i>	37
<b>FIRST SCHEDULE—continued</b>		
<b>Provisions</b>		<b>Limits on application</b>
(d) Provide reasonable access for maintenance and clearing blockages,		
(e) Avoid the likelihood of damage to any <i>outfall</i> , in a manner acceptable to the <i>network utility operator</i> , and		
(f) Avoid the likelihood of damage from superimposed loads or normal ground movements.		

# Contents

	Page		Page
<b>References</b>	<b>7</b>	<b>Acceptable Solution E1/AS1</b>	<b>33</b>
<b>Definitions</b>	<b>9</b>	<b>1.0 Limitations of the Solution</b>	<b>33</b>
<b>Verification Method E1/VM1</b>	<b>11</b>	<b>2.0 Minimum Acceptable Floor Level</b>	<b>33</b>
<b>1.0 Scope</b>	<b>11</b>	<b>3.0 Drainage System Materials and Construction</b>	<b>34</b>
<b>2.0 Estimation of Surface Water Run-off</b>	<b>11</b>	3.1 Materials	34
2.1 Run-off coefficient	12	3.2 Sizing of drains	34
2.2 Rainfall intensity	12	3.3 Alignment and gradient of drains	34
2.3 Time of concentration	13	3.4 Minimum gradients	34
<b>3.0 Sizing of Surface Water System</b>	<b>16</b>	3.5 Jointing of drains	36
3.1 Minimum size of drains	16	3.6 Surface water inlets to drains	36
3.2 Hydraulic design	16	3.7 Access for maintenance	37
3.3 Pipe materials	17	3.8 Testing of drains	39
<b>4.0 Secondary Flow</b>	<b>17</b>	3.9 Bedding and backfilling	39
4.1 Secondary flow from a piped surface water drainage system upstream of the site	18	<b>4.0 Downpipes</b>	<b>42</b>
4.2 Secondary flow from an open water course upstream of the site	24	4.1 Materials	42
4.3 Secondary flow from site to downstream drainage system	27	4.2 Sizing of downpipes	42
<b>5.0 Energy Losses Through Structures</b>	<b>27</b>	4.3 Installation of downpipes	42
<b>6.0 Minimum Velocity</b>	<b>27</b>	<b>5.0 Roof Gutters</b>	<b>42</b>
<b>7.0 Outfall Protection</b>	<b>29</b>	5.1 Size of roof gutter	42
<b>8.0 Drain Leakage Tests</b>	<b>29</b>	5.2 Materials	44
8.1 Water test	29	5.3 Gradients	44
8.2 Low pressure air test	29	5.4 Thermal movement	44
8.3 High pressure air test	30	5.5 Overflow outlets	44
<b>9.0 Disposal to soak pit</b>	<b>30</b>	<b>E1/AS1 Appendix A</b>	
		Rainfall intensities	45
		<b>Acceptable Solution E1/AS2</b>	<b>52</b>
		<b>1.0 AS/NZS 3500.3 Stormwater drainage</b>	<b>52</b>
		<b>Index</b>	<b>54</b>

Amend 4  
Dec 2000

Amend 11  
Nov 2020

Amend 13  
Nov 2023

Amend 4  
Dec 2000





# References

Amend 1  
Sep 1993

For the purposes of New Zealand Building Code (NZBC) compliance, the Standards and documents referenced in this Verification Method and Acceptable Solutions (primary reference documents) must be the editions, along with their specific amendments, listed below. Where these primary reference documents refer to other Standards or documents (secondary reference documents), which in turn may also refer to other Standards or documents, and so on (lower-order reference documents), then the version in effect at the date of publication of this Verification Method and Acceptable Solutions must be used.

Amend 8  
Oct 2011Amend 9  
Feb 2014  
Amend 11  
Nov 2020Amend 7  
Sep 2010Amends  
9 and 11

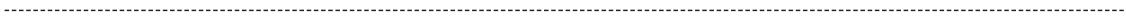
## Standards New Zealand

## Where quoted

Amends 1 & 12	AS/NZS 1254: 2010 PVC-U pipes and fittings for stormwater and surface water applications <i>Amend: 1, 2, 3</i>	AS1 Table 1, Table 3	
Amends 9 & 12			
Amends 10 & 12	AS/NZS 1260: 2017 PVC-U Pipes and fittings for drain, waste and vent application	AS1 Table 1, Table 4	Amend 11 Nov 2020
Amends 9, 10, 11			
	AS/NZS 1734: 1997 Aluminium and aluminium alloys – Flat sheets, coiled sheet and plate	AS1 Table 4, Table 6	
Amend 8 Oct 2011	AS/NZS 2032: 2006 Installation of PVC Pipe Systems <i>Amend: 1</i>	AS1 Table 3, 3.9.8	
	AS/NZS 2033: 2008 Installation of polyethylene pipe systems <i>Amend: 1, 2</i>	AS1 Table 3	
Amend 8 Oct 2011			
Amends 9, 10, 11 & 12	AS/NZS 2280: 2020 Ductile iron pipes and fittings <i>Amend: 1</i>	AS1 Table 1, Table 3	
	AS/NZS 2566:- Buried Flexible pipelines		
Amend 7 Sep 2010	Part 1: 1998 Structural Design	AS1 3.9.8	
Amend 12 Nov 2023			
Amend 7 Sep 2010	Part 2: 2002 Installation <i>Amend: 1, 2, 3</i>	AS1 3.9.8, Table 3	Amend 8 Oct 2011
Amends 10 & 11			
	AS/NZS 3500:- Plumbing and drainage		
Amends 11 & 12	Part 3: 2021 Stormwater drainage	AS2 1.0, 1.0.1, 1.0.4	
	NZS 3501: 1976 Specifications for copper tubes for water, gas, and sanitation <i>Amends: 1, 2, 3</i>	AS1 Table 4	
Amend 12 Nov 2023			
	NZS 3604: 2011 Timber framed buildings	AS1 3.9.7	Amend 5 July 2001
Amends 1, 4, 7, 8, 9			
	AS/NZS 4058: 2007 Precast concrete pipes (pressure and non-pressure)	AS1 Table 1	
Amend 7 Sep 2010	AS/NZS 4130: 2018 Polyethylene (PE) pipes for pressure applications <i>Amend: 1</i>	AS1 Table 1, Table 4	
Amends 8, 9, 10, 11, 12			

		<b>Where quoted</b>
Amends 1, 4, 10	NZS 4229: 2013 Concrete masonry buildings not requiring specific design	AS1 3.9.7
	NZS 4442: 1988 Welded steel pipes and fittings for water, sewage and medium pressure gas	AS1 Table 1, Table 3
Amend 7 Sep 2010 Amend 8 Oct 2011 Amend 11 Nov 2020	AS/NZS 5065: 2005 Polyethylene and polypropylene pipe and fittings for drainage and sewerage applications <i>Amend: 1, 2</i>	AS1 Table 1
<b>British Standards Institution</b>		
Amend 7 Sep 2010		
Amends 8 & 12	BS EN 1172: 2011 Copper and copper alloys – sheet and strip for building purposes	AS1 Table 4, Table 6
Amend 7 Sep 2010	BS EN 1759 Part 1: 2004 Flanges and their joints. Circular flanges for pipes, valves, fittings and accessories, class-designated. Steel flanges, NPS 1/2 to 24.	AS1 Table 3
Amend 8 Oct 2011		
Amend 7 Sep 2010		
<b>Standards Association of Australia</b>		
Amend 7 Sep 2010		
	AS 1273: 1991 Unplasticised PVC (UPVC) downpipes and fittings for rainwater	AS1 Table 4, Table 6
Amends 7, 11, 12	AS 1397: 2021 Continuous hot-dip metallic coated steel sheet and strip – Coatings of zinc and zinc alloyed with aluminium and magnesium	AS1 Table 4, Table 6
	AS 1432: 2004 Copper tubes for plumbing, gasfitting and drainage applications	AS1 Table 4
	AS 1528: Stainless steel tubes and tube fittings for food processing and hygienic applications Part 1: 2019 Tubes	AS1 Table 4
Amend 12 Nov 2023	AS 1566: 1997 Copper and copper alloys – Rolled flat products	AS1 Table 4, Table 6
	AS 1579: 2001 Arc welded steel pipes and fittings for water and waste water	AS1 Table 1
Amend 7 Sep 2010	AS 1646: 2007 Elastomeric seals for waterworks purposes	AS1 Table 3
Amend 7 Sep 2010	AS 1741: 1991 Vitrified clay pipes and fittings with flexible joints – sewerage quality	AS1 Table 1

		<b>Where quoted</b>	
Amend 12 Nov 2023	AS 1866: 1997	Aluminium and aluminium alloys – Extruded rod, bar, solid and hollow shapes	AS1 Table 4
Amends 7 and 11 Amend 4 Dec 2000	AS 3706:- Part 1: 2012	Geotextiles – Methods of test General requirements, sampling, conditioning, basic physical properties and statistical analysis	VM19.0.4
<b>American Society for Testing and Materials</b>			
Amend 12 Nov 2023	ASTM A240/A240M:2020	Standard Specification for Chromium and Chromium-Nickel Stainless Steel Plate, Sheet, and Strip for Pressure Vessels and for General Applications	AS1 Table 4, Table 6
<b>New Zealand Legislation</b>			
	Resource Management Act 1991		VM12.1.2



# Definitions

Amend 7  
Sep 2010

This is an abbreviated list of definitions for words or terms particularly relevant to this Verification Method and Acceptable Solutions. The definitions for any other italicised words may be found in the New Zealand Building Code Handbook.

Amends  
9 and 11

**Access chamber** A chamber with working space at *drain* level through which the *drain* passes either as an open channel or as a pipe incorporating an inspection point.

**Annual Exceedance Probability (AEP)** The probability that a given rainfall intensity will be exceeded in any one year, expressed as a percentage.

Amend 11  
Nov 2020

**Building** has the meaning given to it by sections 8 and 9 of the *Building Act 2004*.

Amend 7  
Sep 2010

**Construct** in relation to a *building*, includes to build, erect, prefabricate, and relocate; and *construction* has a corresponding meaning.

**Drain** A pipe normally laid below ground level including fittings and equipment and intended to convey *foul water* or *surface water* to an *outfall*.

**Inspection chamber** A chamber with working space at ground level through which the *drain* passes either as an open channel or as a pipe incorporating an *inspection point*.

**Inspection point** A removable cap at *drain* level through which access may be made for cleaning and inspecting the drainage system.

**Network utility operator** means a *person* who:

- (a) undertakes or proposes to undertake the distribution or transmission by pipeline of natural or manufactured gas, petroleum, biofuel, or geothermal energy; or
- (b) operates or proposes to operate a network for the purpose of
  - (i) telecommunication as defined in section 5 of the Telecommunications Act 2001; or
  - (ii) radiocommunications as defined in section 2(1) of the Radiocommunications Act 1989; or
- (c) is an electricity operator or electricity distributor as defined in section 2 of the Electricity Act 1992 for the purpose of

Amend 8  
Oct 2011

line function services as defined in that section; or

(d) undertakes or proposes to undertake the distribution of water for supply (including irrigation); or

(e) undertakes or proposes to undertake a drainage or sewerage system.

Amend 7  
Sep 2010

**Other property** means any land or *buildings* or part thereof which are:

- a) Not held under the same *allotment*; or
- b) Not held under the same ownership – and includes any road.

**Outfall** That part of the disposal system receiving *surface water* or *foul water* from the drainage system. For *foul water*, the *outfall* may include a *foul water sewer* or a septic tank. For *surface water*, the *outfall* may include a natural water course, kerb and channel, or a soakage system.

**Rodding point** A removable cap at ground level through which access may be made for cleaning and inspecting the drainage system.

**Secondary flow path** The path over which *surface water* will follow if the drainage system becomes overloaded or inoperative.

**Sewer** A *drain* that is under the control of, or maintained by, a *network utility operator*.

**Sitework** means work on a *building* site, including earthworks, preparatory to or associated with the *construction*, *alteration*, *demolition* or removal of a *building*.

**Sump** A chamber which is installed in the *drain* and incorporates features to intercept and retain silt, gravel and other debris.

**Surface water** All naturally occurring water, other than sub-surface water, which results from rainfall on the site or water flowing onto the site, including that flowing from a *drain*, stream, river, lake or sea.

Amend 7  
Sep 2010

**Territorial authority (TA)** means a city council or district council named in Part 2 of Schedule 2 of the Local Government Act 2002; and—

- a) in relation to land within the district of a *territorial authority*, or a *building* on or proposed to be built on any such land, means that *territorial authority*; and
- b) in relation to any part of a coastal marine area (within the meaning of the Resource Management Act 1991) that is not within the district of a *territorial authority*, or a *building* on or proposed to be built on any such part, means the *territorial authority* whose district is adjacent to that part.

Amend 7  
Sep 2010

**Trap** A chamber which is installed in the *drain* and incorporates features to intercept and retain floatable debris.

# Verification Method E1/VM1

(Revised by Amendment 4)

## 1.0 Scope

**1.0.1** This Verification Method shall be used only if the *territorial authority* does not have more accurate data available from sophisticated hydrological modelling of the catchment undertaken as part of its flood management plans.

**1.0.2** The following approach provides a method for verifying that a proposed *building* will meet the requirements of NZBC E1.3.1 and E1.3.2 in the following circumstances:

- a) The catchment area does not exceed 100 ha (but see Paragraph 1.0.6 for soak pits), and
- b) The *surface water* results only from rainfall on the catchment and does not include water from other sources such as inundation from rivers, lakes or the sea.

**1.0.3** The method describes how to determine:

- a) The volume of *surface water* arriving at the *building* site from upper areas of the catchment (see Paragraph 2.0),
- b) The size of *drains* necessary to remove *surface water* from the *building* site (see Paragraph 3.0), and
- c) The nature and volume of secondary flows likely to reach the *building* 1 from overloaded culverts, *drains* or open channels in the upper catchment (see Paragraph 4.0).

**1.0.4** The procedure described for sizing *drains* only applies where free flow occurs at the outlet. The outlet must not be restricted by hydraulic impediments such as control gates, a pump station, or submerged outlets in a river, a lake or the sea.

### COMMENT:

The capacity of *drains* which do not have a free flowing outlet shall be calculated by specific design in a manner which incorporates the effect of the restriction.

**1.0.5** A method is provided for determining appropriate *outfall* protection.

**1.0.6** A procedure is provided for determining soak pit requirements for *surface water* disposal. Such disposal is subject to suitable ground conditions, as confirmed by site tests.

### COMMENT:

1. Where soak pits are used the overall ground stability may need to be verified but this is outside of the scope of this Verification Method.
2. Soak pit *surface water* disposal may require a resource management consent.

**1.0.7** The design procedures in this document must be performed by a *person* who, on the basis of experience or qualifications, is competent to apply them.

**1.0.8** This document makes no allowance for blockages to the intakes of *drains* or culverts. The procedures of this document shall only be used where the designer demonstrates that this approach is justified for the particular *building* work under consideration.

### COMMENT:

The likelihood of blockage and the resulting risks will vary from project to project and need to be considered by the designer before applying this document.

**1.0.9** The "Comments" in this document provide comment, background or general information but do not form part of this Verification Method.

## 2.0 Estimation of Surface Water Run-Off

**2.0.1** *Surface water* run-off for the catchment shall be calculated using the Rational Method. The formula to be used is:

$$Q_c = CIA_c/360$$

where

$$Q_c = \text{catchment run-off (m}^3\text{/s).}$$

$$C = \text{run-off coefficient (see Table 1).}$$

$$I = \text{rainfall intensity (mm/hr).}$$

$$A_c = \text{area (hectares) of catchment above the point being considered.}$$

**Table 1: Run-off Coefficients**  
Paragraphs 2.0.1, 2.1.1, 2.1.3

Description of surface	C
<b>Natural surface types</b>	
Bare impermeable clay with no interception channels or run-off control	0.70
Bare uncultivated soil of medium soakage	0.60
Heavy clay soil types:	
– pasture and grass cover	0.40
– bush and scrub cover	0.35
– cultivated	0.30
Medium soakage soil types:	
– pasture and grass cover	0.30
– bush and scrub cover	0.25
– cultivated	0.20
High soakage gravel, sandy and volcanic soil types:	
– pasture and grass cover	0.20
– bush and scrub cover	0.15
– cultivated	0.10
Parks, playgrounds and reserves:	
– mainly grassed	0.30
– predominantly bush	0.25
Gardens, lawns, etc.	0.25
<b>Developed surface types</b>	
Fully roofed and/or sealed developments	0.90
Steel and non-absorbent roof surfaces	0.90
Asphalt and concrete paved surfaces	0.85
Near flat and slightly absorbent roof surfaces	0.80
Stone, brick and precast concrete paving panels	
– with sealed joints	0.80
– with open joints	0.60
Unsealed roads	0.50
Railway and unsealed yards and similar surfaces	0.35
<b>Land use types</b>	
Industrial, commercial, shopping areas and town house developments	0.65
Residential areas in which the impervious area is less than 36% of gross area	0.45
Residential areas in which impervious area is 36% to 50% of gross area	0.55
Note: Where the impervious area exceeds 50% of gross area, use method of Paragraph 2.1.2.	

Amend 10  
Jan 2017Amend 10  
Jan 2017

characteristics. For catchments having a mixture of different types, the run-off coefficient shall be determined by averaging the value for individual parts of the catchment by using the formula:

$$C = \frac{\sum C_i A_i}{A_c}$$

where

$C$  = the run-off coefficient for the catchment.

$C_i$  = the run-off coefficient for a particular land use.

$A_i$  = the area of land to which  $C_i$  applies.

$A_c$  = the catchment area.

**COMMENT:**

1. The run-off coefficient  $C$  is the variable in the rational formula least able to be precisely determined, and represents the integrated effects of such things as infiltration, storage, evaporation, natural retention and interception, all of which affect the time distribution and peak rate of run-off.

2. The run-off coefficients given in Table 1 assume saturated ground conditions from previous rain, and shall be used in the calculation of *surface water* run-off.

**2.1.2** The chosen run-off coefficient shall be based on the conditions likely to exist after the full catchment development allowable by the operative plan under the Resource Management Act 1991.

**2.1.3 Slope correction**

The values of run-off coefficient given in Table 1 shall be adjusted for slope in accordance with Table 2.

**COMMENT:**

The values in Table 1 assume an average sloping terrain of 5-10% (i.e. gently rolling). However, if the terrain is flatter or steeper this will have the effect of slowing down or speeding up overland flow. The above adjustment allows for this.

**2.2 Rainfall intensity**

**2.2.1** The rainfall intensity shall be that for a storm having a duration equal to the time of concentration as determined by Paragraph 2.3.1, and a probability of occurrence as given by NZBC E1.3.1 or E1.3.2 as appropriate. Either local rainfall intensity curves produced by the *territorial authority* or rainfall frequency

**2.1 Run-off Coefficient**

**2.1.1** Table 1 lists run-off coefficients appropriate to a variety of land uses and soil



duration information produced by NIWA shall be used to determine the rainfall intensity.

**COMMENT:**

Rainfall intensity curves are available for most areas. These have been developed from meteorological data. Rainfall frequency-duration tables for each official rain gauge throughout New Zealand are also available.

Rainfall intensity data is also available online in digital form from the National Institute for Water and Atmospheric Research (NIWA) High Intensity Rainfall Design System (HIRDS).

HIRDS provides rainfall intensity estimates for any location in New Zealand based on historical rain gauge data and also projections of future rainfall intensities for various climate change scenarios.

Where differing design rainfall intensities are provided for a particular location, the most conservative rainfall intensity should be used for design calculations.

Amend 11  
Nov 2020

Table 2: Slope Correction for Run-off Coefficients Paragraph 2.1.3		
Ground slope Adjust C by:		
0-5%	subtracting	0.05
5-10%	no adjustment	
10-20%	adding	0.05
20% or steeper	adding	0.10

**2.3 Time of concentration**

**2.3.1** The time of concentration used to determine rainfall intensity is the time taken for *surface water* run-off from the furthest point (in time) of the catchment to reach the design point. Flow time calculations shall take account of catchment run-off coefficients and slopes.

Time of concentration for the catchment  $t_c$  (minutes) shall be calculated from the formula:

$$t_c = t_e + t_f$$

but shall be no less than 10 minutes.

Where

$t_e$  = time of entry (minutes) which is the run-off time for overland travel (i.e. via ground, roofs, downpipes, carriageways or road channels) to the point of entry to a *drain* or open channel.

$t_f$  = time (minutes) of network flow, (comprising flow in pipes and open channels), to the design point.

**COMMENT:**

In some catchments due to shape, *surface water* network and varying permeabilities within the catchment, part of the catchment under consideration may produce a higher peak flow than the whole of the catchment. Although the area for the part catchment is smaller, this may be more than offset by the higher intensity storm associated with a shorter time of concentration and storm duration. This situation will generally arise where the lower reaches of a catchment are densely developed.

**2.3.2 Time of entry  $t_e$**

The time of entry  $t_e$ :

a) Where the catchment area has a well defined and regularly repeated pattern for directing the *surface water* to the *drain* or open channel, the time of entry may be taken as:

$t_e$  = 5 minutes for commercial or industrial areas where greater than 50% of the surface of the catchment area feeding the *drain* or open channel consists of roofed, asphalt, concrete, paved or metallised surfaces.

$t_e$  = 7 minutes for residential areas where the impervious area exceeds 50% of gross area.

$t_e$  = 10 minutes for low density residential areas where the impervious area is 36% to 50% of gross area.

b) Where the catchment does not have a well defined and regularly repeated pattern or where the catchment is longer than 1.0 km, the time of entry  $t_e$  shall be the sum of the time of overland flow and, if applicable, the time of road channel flow as given in i) and ii) below:

i) the time of overland flow shall be determined by the formula:

$$t = 100 nL^{0.33}/s^{0.2}$$

where

$t$  = time (minutes).

$L$  = length of overland flow (m).

s = slope (%).

n = Manning's 'n' (roughness coefficient).

The results from this formula, for normal surface types, are shown in Figure 1.

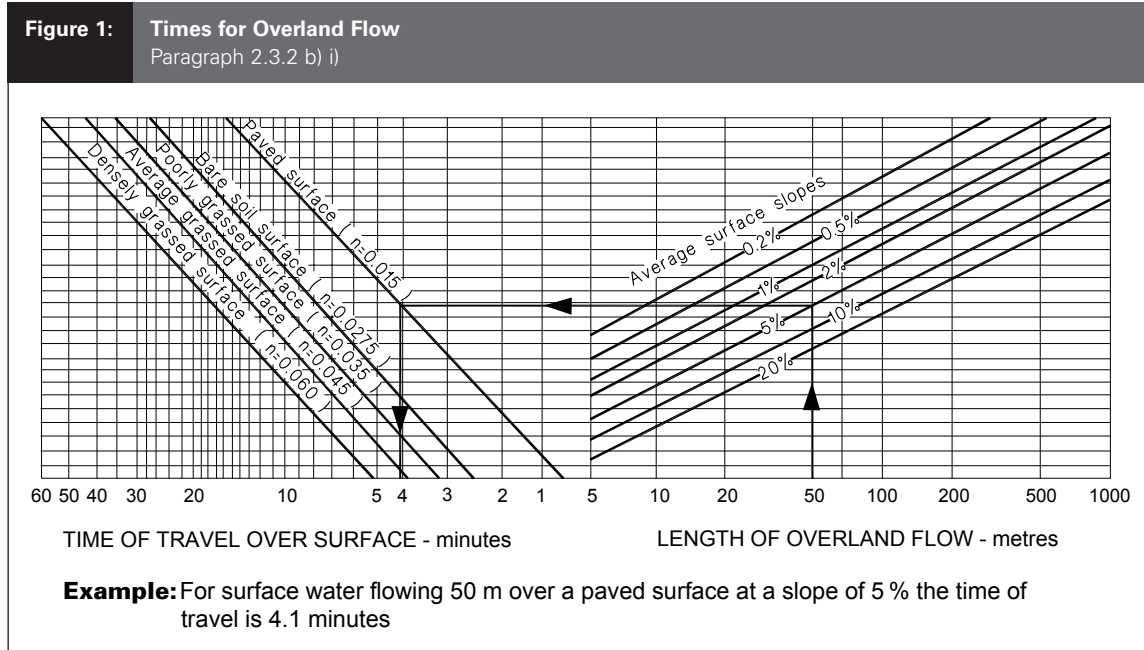
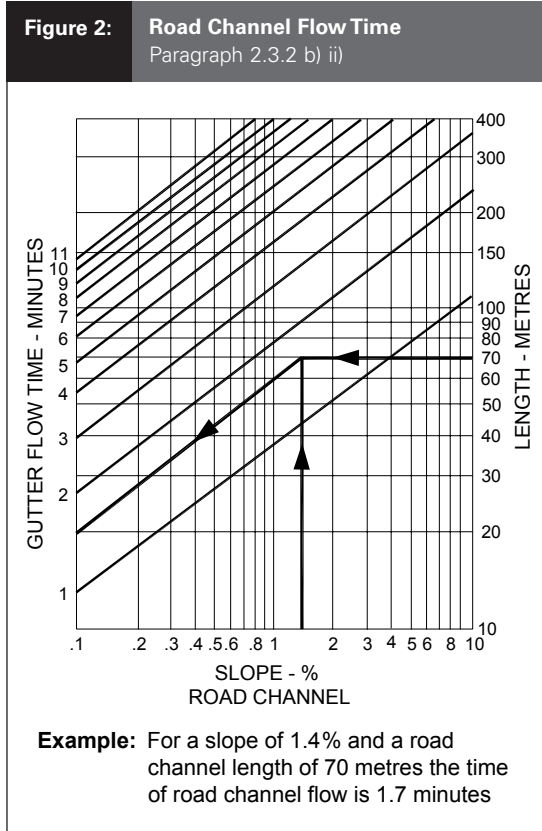
- ii) The time of road channel flow, which is the time taken for water to flow from the point of entering the road channel, to the point of discharge to a *sump*, catchpit, *drain* or other outlet, shall be determined from Figure 2.

**2.3.3 Time of network flow**

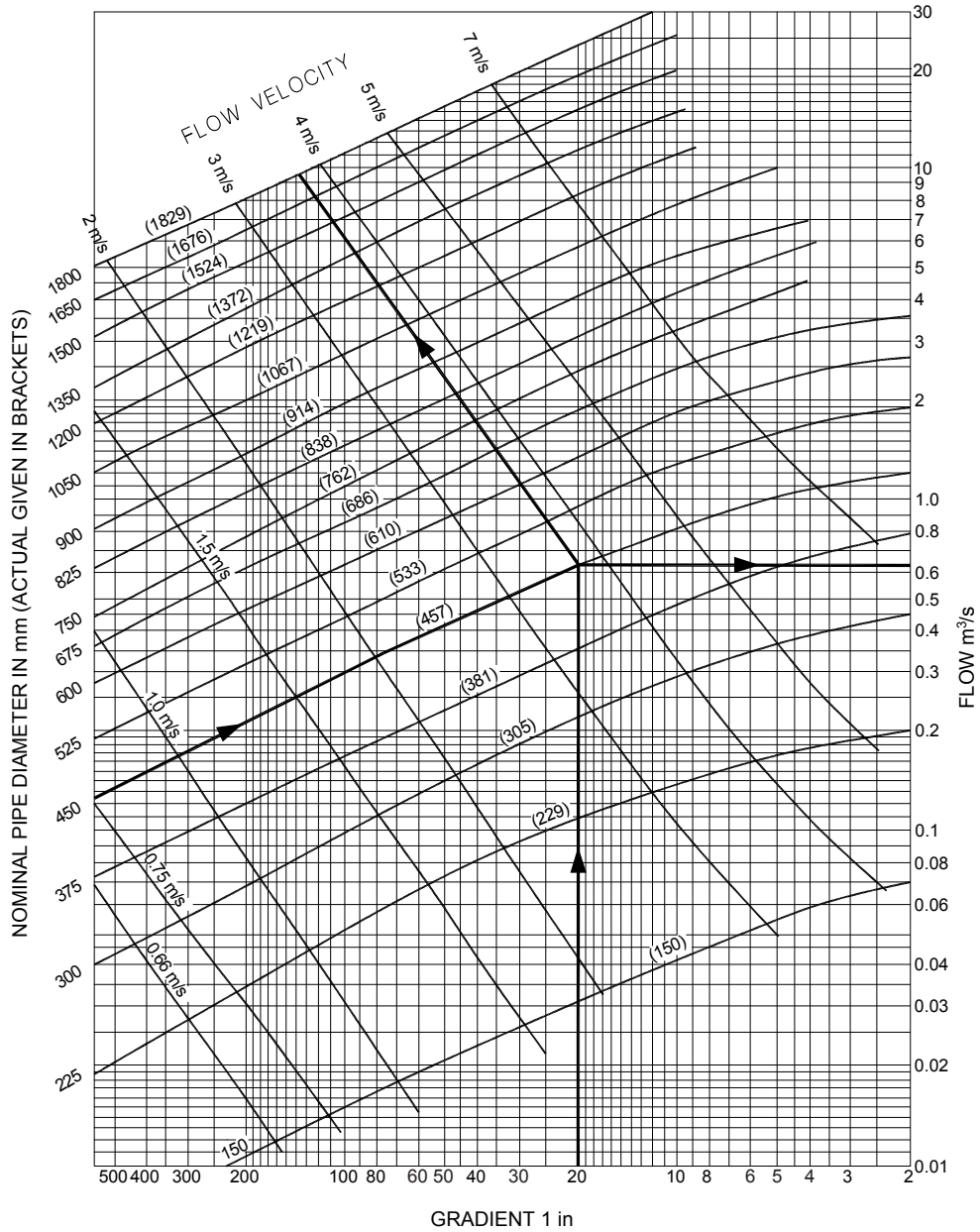
The time of network flow  $t_f$  shall be determined from the sum of the travel times within pipes and open channels.

**2.3.4 Time of pipe flow**

The time of pipe flow shall be calculated from the velocity as determined from Figure 3. Where the pipe changes in material, diameter or gradient the time taken in each section of the pipe shall be calculated and the component times summed. For pipes with Manning's 'n' other than 0.013 the velocity determined from Figure 3 shall be multiplied by the ratio of 0.013/n. Other values of Manning's 'n' for different pipe materials are given in Table 3.



**Figure 3: Pipe Flow Relationships for Different Combinations of Internal Diameter, Velocity and Gradient**  
 (Based on Manning's formula using  $n = 0.013$  with an allowance for air entrainment)  
 Paragraphs 2.3.4 and 3.2.1



**Example:** A 450 internal diameter pipe with a gradient of 1 in 20 will have a flow of 0.63  $m^3/s$  at a velocity of 3.75 m/s

Amend 12  
Nov 2023

**Table 3: Mannings 'n'**  
Paragraphs 2.3.4, 3.2.1, 4.1.6, 4.1.8, 4.1.11 and 4.2.1

Description	Value of 'n'
<b>Circular pipes</b>	
HDPE and uPVC	0.011
Ceramic and concrete	0.013
<b>Culverts</b>	
Cast-in-situ concrete	0.015
Corrugated metal	0.025
<b>Open stream</b>	
Straight uniform channel in earth and gravel in good condition	0.0225
Unlined channel in earth and gravel with some bends and in fair condition	0.025
Channel with rough stoney bed or with weeds on earth bank and natural streams with clean straight banks	0.03
Winding natural streams with generally clean bed but with some pools and shoals	0.035
Winding natural stream with irregular cross-section and some obstruction with vegetation and debris	0.045
Irregular natural stream with obstruction from vegetation and debris	0.06
Very weedy irregular winding stream obstructed with significant overgrown vegetation and debris	0.1

**2.3.5 Time of open channel flow**

The time of flow in open channels (either watercourses or lined channels), shall be calculated by means of Manning's formula as given by Paragraph 3.0.

**2.3.6 Alternative method to determine time of concentration**

Where there are significant changes in gradient along the channel slope or where the open channel is in a rural area, the time of concentration  $t_c$  may be determined from:

$$t_c = 0.0195 (L^3 / H)^{0.385}$$

where

- $t_c$  = time of concentration (minutes).
- L = length of catchment (m) measured along the flow path.
- H = rise from bottom to top of catchment (m).

**2.3.7** If the actual catchment slope varies significantly from the value H/L (e.g. with a sudden steepening in the upper reaches) the average slope and height h shall be determined from the equal areas method shown in Figure 4. Height h shall be substituted for H in the formula.

**3.0 Sizing of Surface Water System**

**3.1 Minimum size of drains**

**3.1.1** To avoid blockages, *surface water drains* shall have an internal diameter of no less than 85 mm.

**3.1.2** Except as allowed by Paragraph 5.0.2, the internal diameter of a *drain* shall not decrease in size in the direction of flow.

**3.2 Hydraulic design**

**3.2.1** The cross-sectional area of the *drain* conveying surface water run-off  $Q_c$  to the *outfall* shall be determined by:

$$A_p = Q_c / v$$

where

$A_p$  = cross-sectional area of *drain* (m<sup>2</sup>).

$Q_c$  = *surface water* run-off (m<sup>3</sup>/s).

v = flow velocity (m/s).

The flow velocity v shall be determined from Manning's formula:

$$v = R^{2/3} S^{1/2} n^{-1}$$

where

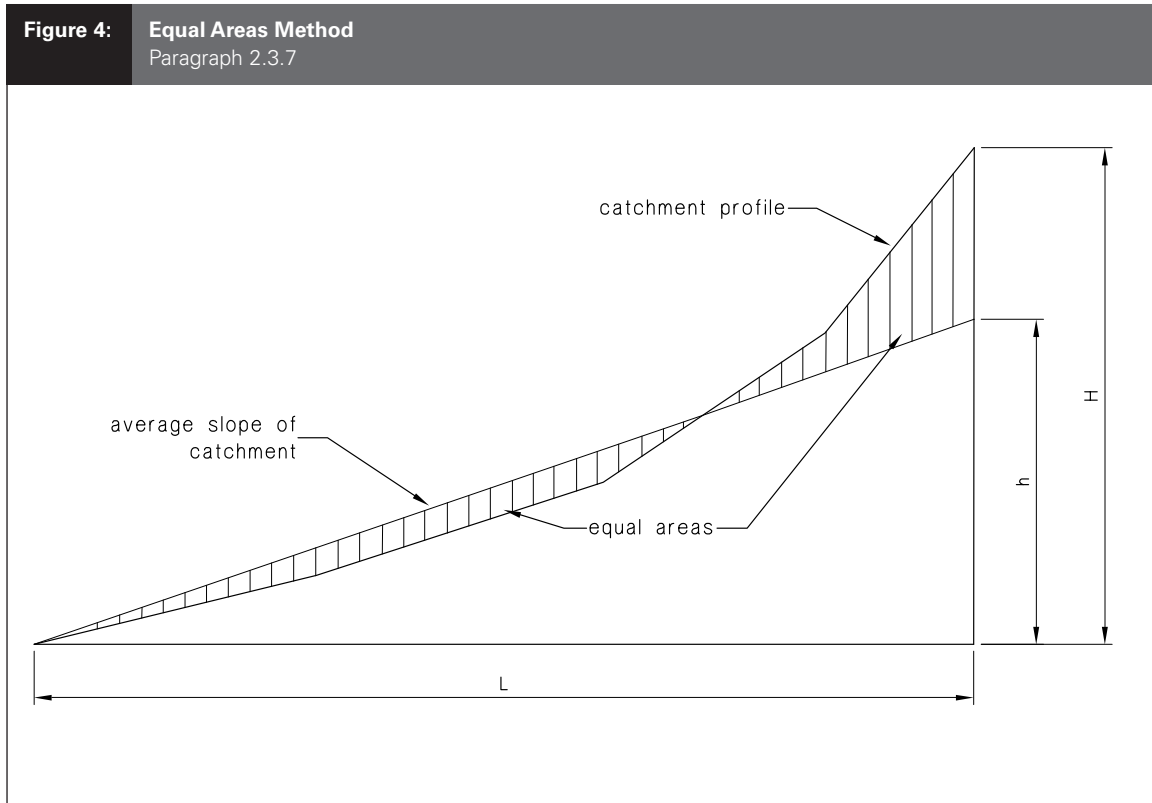
R = hydraulic radius (m) =  $A_p / P$ .

P = wetted perimeter of the cross-section of the flow (m).

S = slope = vertical rise/horizontal distance.

n = Manning's 'n' (roughness coefficient). See Table 3.

Where the *drain* is to be constructed using a piped section, Figure 3 may be used to determine pipe size instead of the above calculation procedure. Where the pipe material has a Manning's 'n' of 0.013, Figure 3 can be used directly. For other values of Manning's 'n', the flow in the pipe  $Q_p$  shall be modified



by multiplying it by the ratio of  $n/0.013$  before entering the Figure.

**3.2.2** The designer shall estimate the headwater depth  $H_w$  (height of water level above inlet invert, refer to Figure 5 (a)) for the size of *drain* (determined from Paragraph 3.2.1), and confirm that there is sufficient ground depth available at the inlet to the *drain* to contain  $H_w$  without causing flooding to the *building* site or secondary flow from the inlet. If there is insufficient depth to contain the headwater the *drain* size shall be increased until  $H_w$  is less than the ground depth available at the *drain* inlet.

**3.2.3** The headwater depth  $H_w$  (m) for the *drain* shall be determined from:

- a) Figure 6 for a circular piped system, or
- b) Figure 7 for a box culvert system.

**3.2.4** Where a *drain* gradient exceeds 1 in 10 an allowance for the bulking of the flow due to air entrainment shall be made by multiplying the area of the pipe by:

$$(1 + kv^2/gR)$$

where

- $k$  = coefficient of entrainment  
= 0.004 for smooth concrete pipes, or  
= 0.008 for cast-in-situ concrete culverts.
- $v$  = flow velocity (m/s).
- $R$  = hydraulic radius (m).
- $g$  = acceleration due to gravity =  $9.8 \text{ m/s}^2$ .

### 3.3 Pipe materials

Pipe materials shall comply with Table 1 of Acceptable Solution E1/AS1.

### 4.0 Secondary Flow

**4.0.1** Secondary flow occurs where *surface water* arrives at the site from an overflowing drainage system upstream in the catchment. Where there is a drainage system, being a pipe, culvert or open water course, upstream of the *building* site, the potential for a

secondary flow path between the drainage system and the site shall be assessed. This shall involve determination of the capacity of the drainage system in conjunction with assessment of the ground levels in the general area.

**COMMENT:**

Secondary flow is not likely to cause flooding at the building site if the surface water run-off from the catchment above the site is less than 0.3 m<sup>3</sup>/s unless the site is in a depression capable of ponding water.

#### 4.1 Secondary flow from a piped surface water drainage system upstream of the site

**4.1.1** This method applies to the assessment of secondary flow upstream of inlet controlled, and some outlet controlled, pipes and culverts (see Figure 5), provided that free flow occurs at the outlet (i.e. the outlet is not restricted by hydraulic obstructions such as control gates, a pump station or submerged outlets in a river or lake).

**4.1.2** The method does not apply to outlet controlled pipes or culverts where the tailwater depth  $T_w$  (m) is less than the height  $D$  (m) of the pipe or culvert (see Figure 5 (f) i.e. outlet not flowing full), and where the estimated headwater depth  $H_w$  (m) is no greater than 0.75  $D$ . Such situations shall be subject to specific design.

**4.1.3** The headwater depth  $H_w$  shall be determined for both the inlet and outlet controlled flow conditions and the maximum value shall be used to assess secondary flow.

#### 4.1.4 Assessment of $H_w$ for inlet controlled pipe or culverts, see Figures 5 (a) and (b)

The headwater depth  $H_w$  for a system with inlet control shall be determined from:

- Figure 6 for a circular piped system, or
- Figure 7 for a box culvert system.

#### 4.1.5 Assessment of $H_w$ for outlet controlled pipes or culverts, see Figures 5 (c), (d) and (e)

The tailwater depth  $T_w$  shall be determined from Paragraphs 4.1.6 and 4.1.7, and the headwater depth  $H_w$  from Paragraph 4.1.8.

**4.1.6** Tailwater depth  $T_w$  (m) shall be calculated by an iterative process from the formula:

$$Q_c = A_f S^{1/2} R^{2/3} / n$$

where

$Q_c$  = catchment surface water run-off or that portion arriving at the pipe or culvert (m<sup>3</sup>/s).

$A_f$  = cross-sectional area of the flow immediately downstream of the pipe or culvert outlet (m<sup>2</sup>).

$S$  = slope of the stream (vertical fall/horizontal distance) immediately downstream of the outlet.

$R$  = hydraulic radius of the stream (m) =  $A_f/P$ .

$P$  = wetted perimeter (m) of the stream flow.

$n$  = Manning's 'n' (roughness coefficient). See Table 3.

**4.1.7** Firstly a tailwater depth  $T_w$  (m) is assumed and, from knowledge of the stream cross-section, the corresponding values of  $A_f$ ,  $P$  and  $R$  are determined. These values are then used in the above formula to calculate  $Q_c$  which is compared to the actual value of  $Q_c$  known to arrive at the pipe. If the calculated value of  $Q_c$  is less than the actual value then the assumed tailwater depth shall be increased and the value of  $Q_c$  recalculated. The procedure shall be repeated until such time as the tailwater depth  $T_w$  used gives two values of  $Q_c$  that agree.

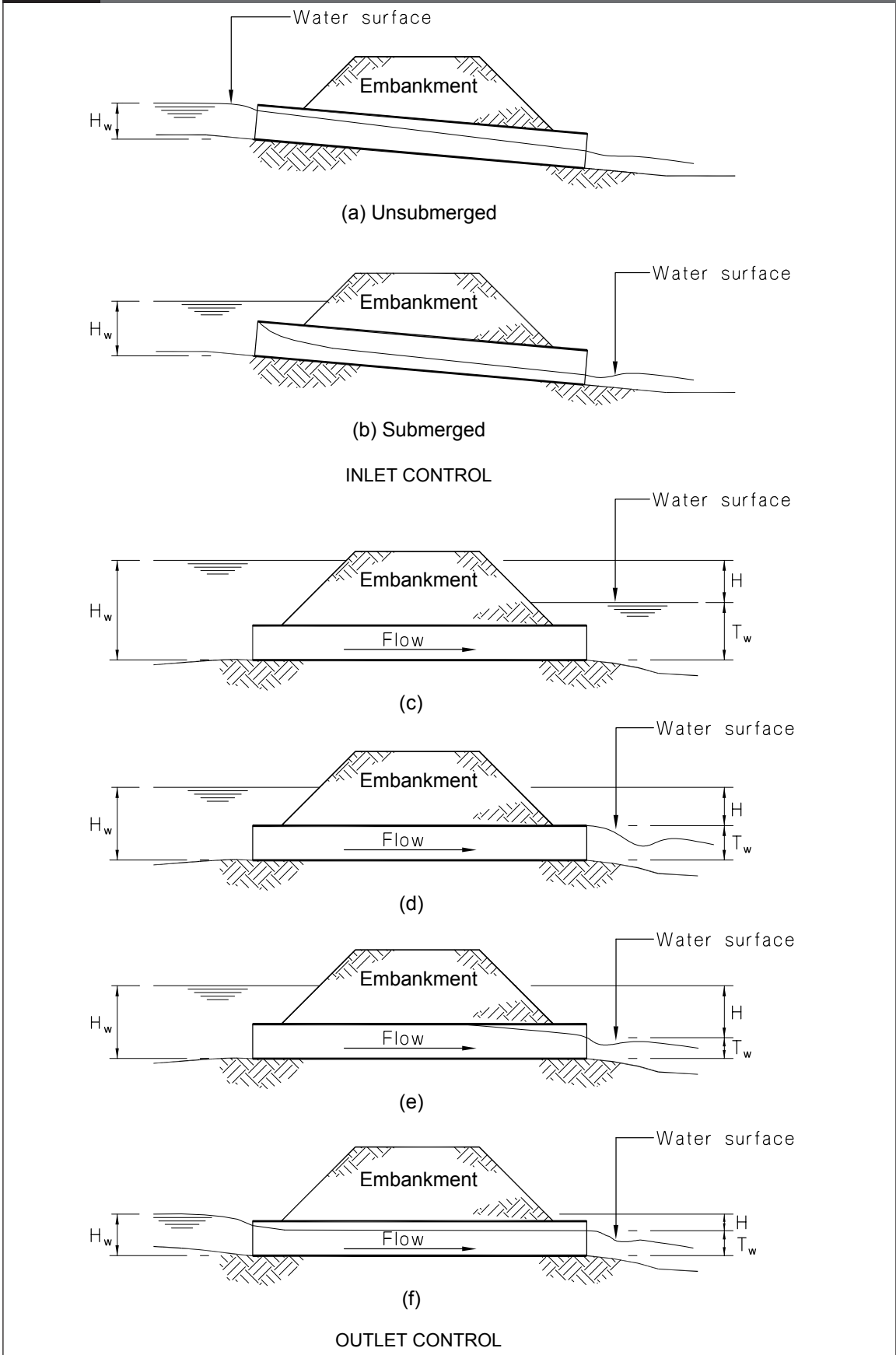
If  $T_w < D$  then  $T_w$  shall be this value or  $(d_c + D)/2$  whichever is the greater, where:

$d_c$  = critical depth (m) and is determined by Figures 8 and 9.

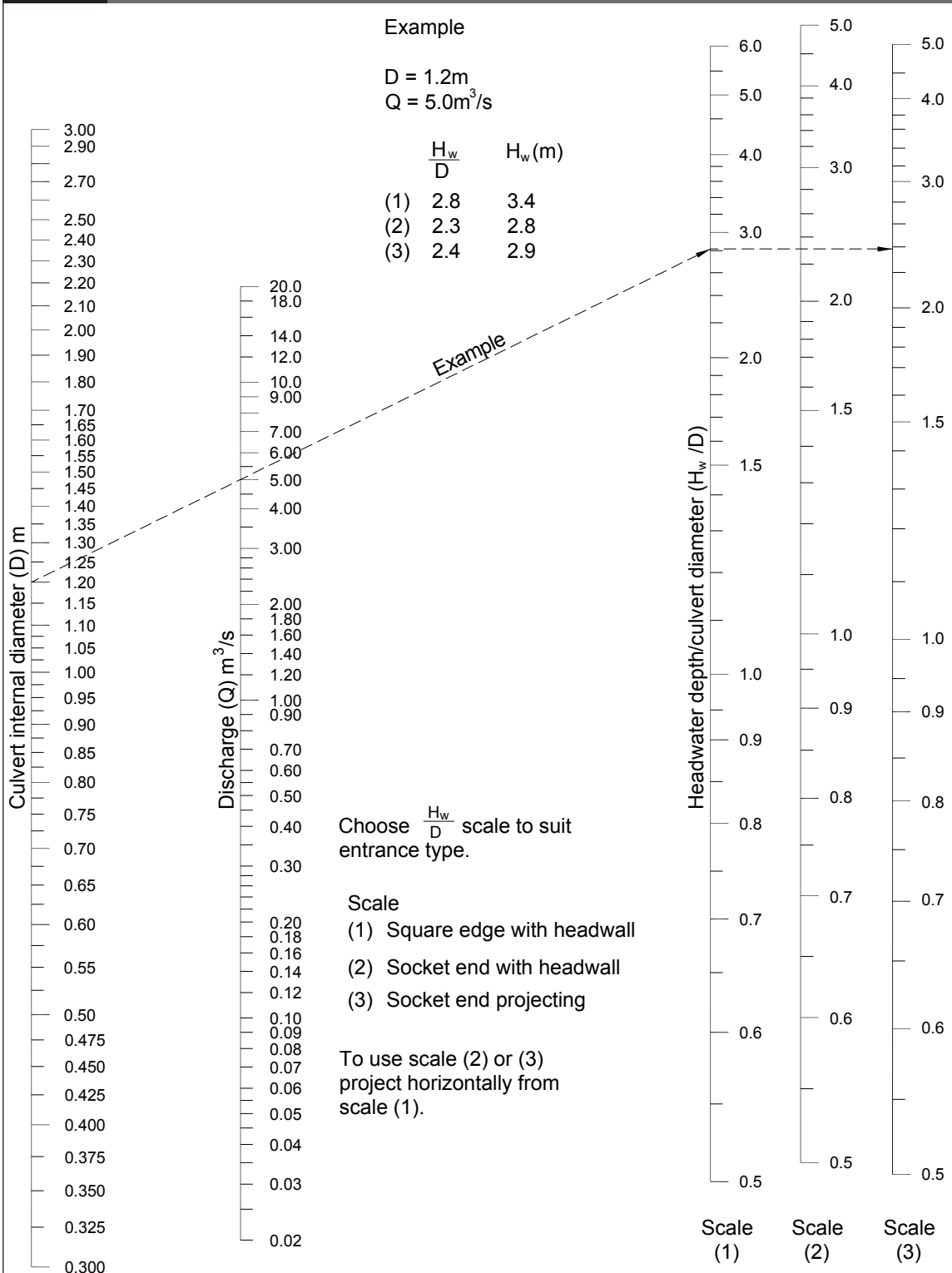
$D$  = internal pipe diameter (m) for Figure 8.

$B$  = culvert width (m) for Figure 9.

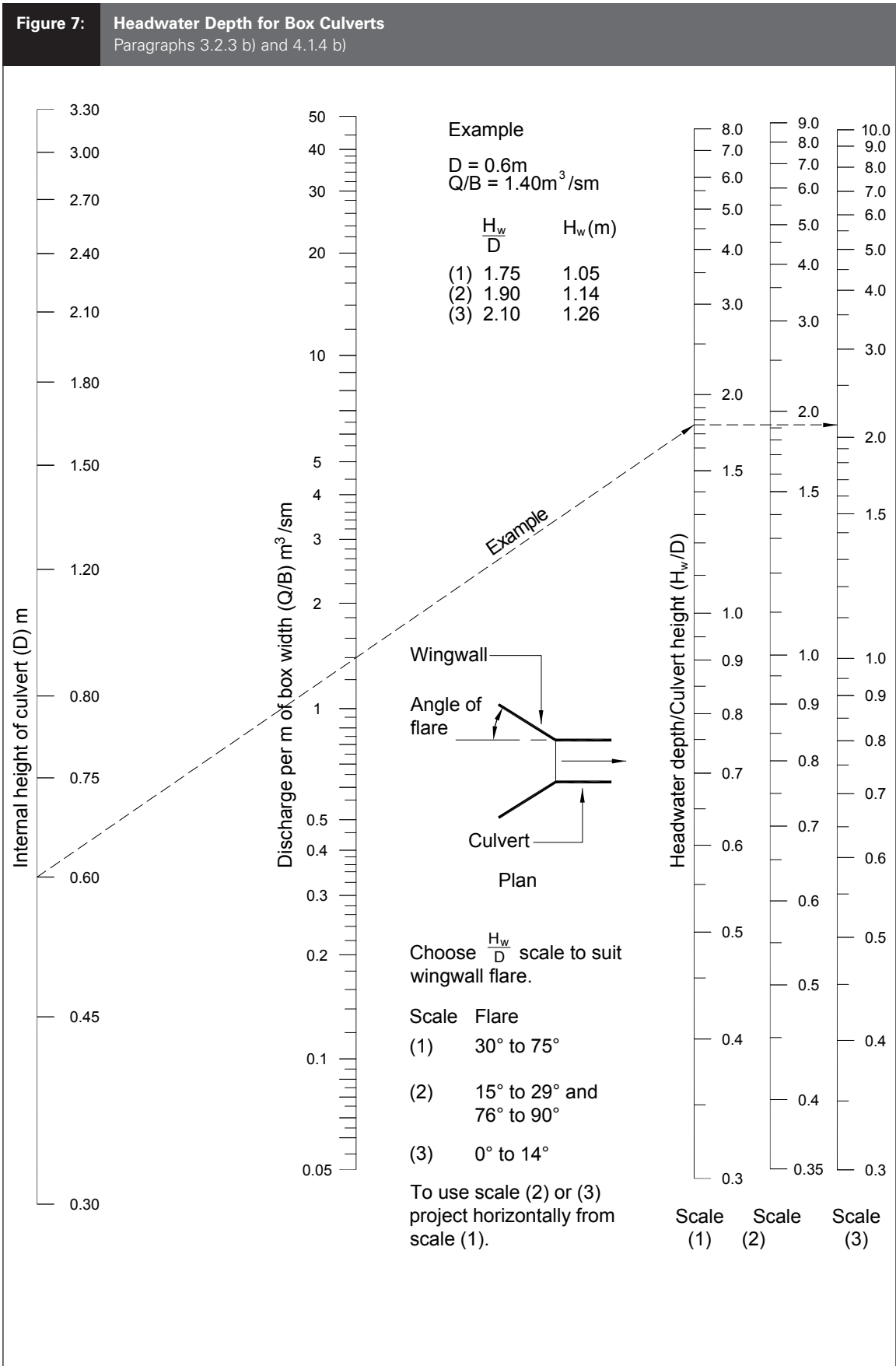
**Figure 5: Pipe Flow Conditions for Inlet and Outlet Control**  
 Paragraphs 3.2.2, 4.1.1, 4.1.2, 4.1.4 and 4.1.5

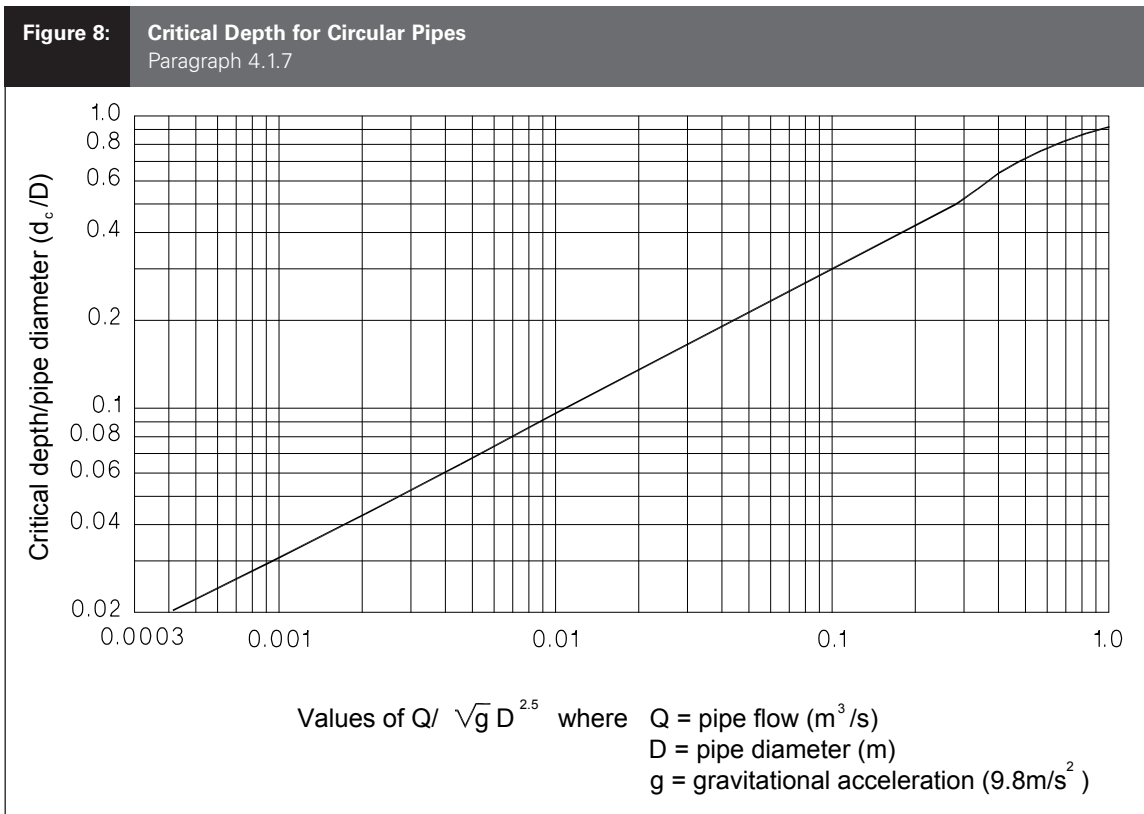


**Figure 6: Headwater Depth for Circular Pipes**  
Paragraphs 3.2.3 a) and 4.1.4 a)









**4.1.8** The headwater depth  $H_w$  (m) shall be calculated by:

$H_w = H + T_w - LS$ , and

$H = \frac{v^2(1 + k_e)}{2g} + \frac{Q_c n}{R^{2/3} A_p} L$

where

$T_w$  = tailwater depth (m).

$H$  = downstream head (m).

$L$  = length of the pipe or culvert (m).

$S$  = slope of the pipe or culvert (vertical fall/horizontal distance) with the vertical fall being measured between the intake and outlet invert levels. If gravels or sand are present in the pipe or culvert then the surface of the gravel or sand shall be taken as the invert level.

$v$  = flow velocity in the pipe or culvert (m/s).

$k_e$  = entrance loss coefficient as given by Table 4.

$Q_c$  = catchment *surface water* run-off or that portion arriving at the pipe ( $m^3/s$ ).

$n$  = Manning's 'n' (roughness coefficient) as given in Table 3.

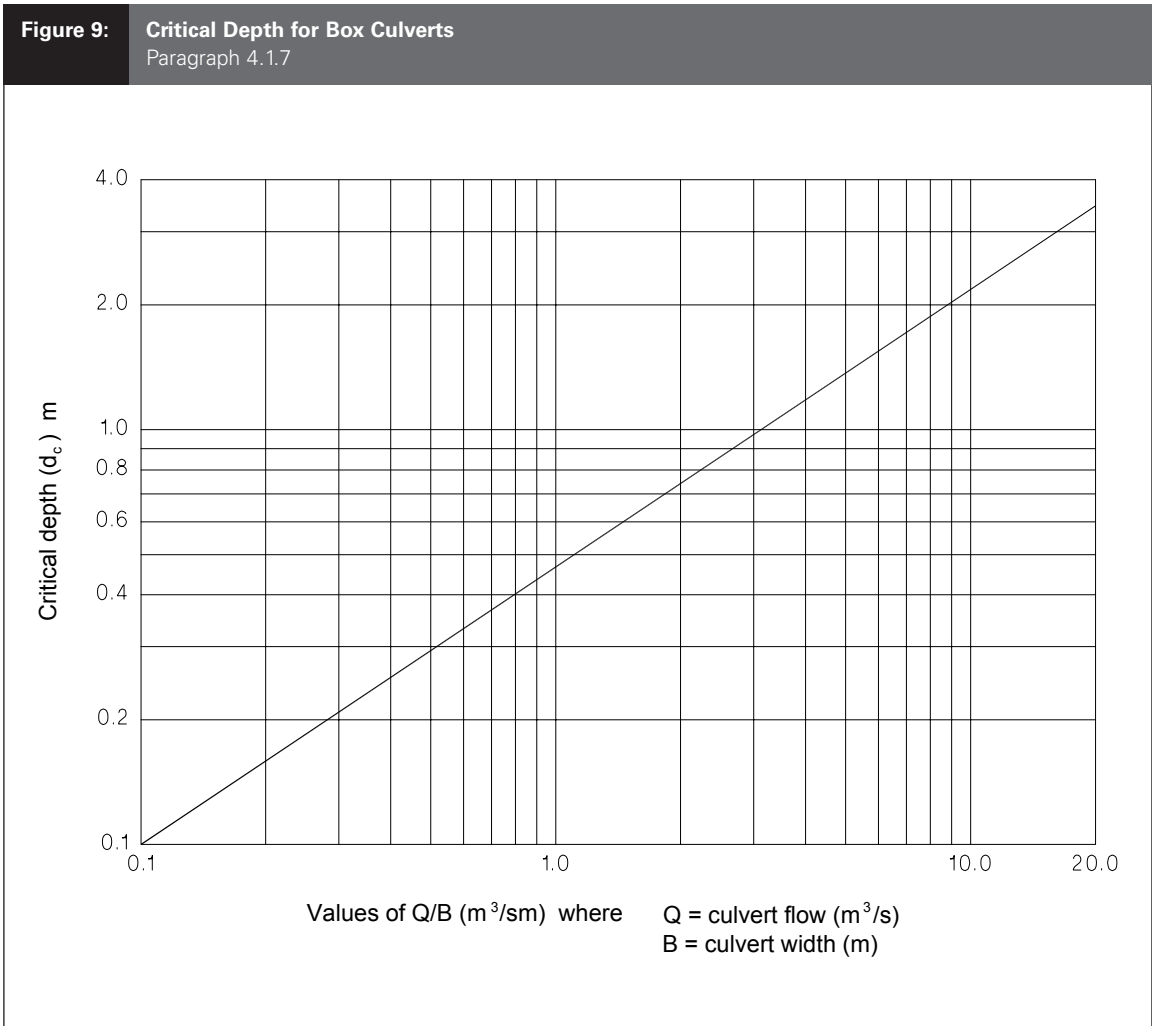
$R$  = hydraulic radius (m).

$A_p$  = cross-sectional area of the pipe or culvert ( $m^2$ ).

**4.1.9** As an alternative to the formula given in Paragraph 4.1.8, Figures 10 and 11 may be used directly to determine downstream  $H$  applying the values of Manning's 'n' and  $k_e$  given in those Figures.

**4.1.10 Determination of secondary flow quantity**

The estimated water surface level, determined from  $H_w$  (m), is the actual water surface if all the *surface water* run-off  $Q_c$  ( $m^3/s$ ) flows through the pipe or culvert. This level shall be compared to the ground levels upstream of the pipe intake to determine if a possible *secondary flow path* exists. If the ground level upstream of the intake is higher than the



water surface level ( $H_w$ ) no secondary flow will occur. If the water surface is higher than the ground level upstream of the intake and the ground contours provide a *secondary flow path* between the possible overflow point and the *building site*, an estimate of the secondary flow volume likely to arrive at the site shall be made using the formula:

$$Q_c = Q_p + Q_{sf}$$

where  $Q_p$  and  $Q_{sf}$  ( $m^3/s$ ) are determined from an iterative process where:

$Q_p$  = flow in the pipe or culvert determined from Paragraphs 4.1.4 and 4.1.5 using an assumed headwater surface level  $H_w$  which allows for secondary flow, and

$Q_{sf}$  = the secondary flow down the *secondary flow path* corresponding to the assumed headwater surface level  $H_w$ .  $Q_{sf}$  shall be determined from Paragraph 4.1.11 provided there is no restriction downstream of the secondary flow overflow point which could cause a backwater effect on either  $Q_p$  or  $Q_{sf}$  capable of ponding water to a height sufficient to reach the level of  $H_w$ . Specific design is required where such restrictions occur.

If the summation of  $Q_p$  and  $Q_{sf}$  is less than  $Q_c$  then a higher  $H_w$  shall be used to recalculate  $Q_p$  and  $Q_{sf}$ . If it is greater than  $Q_c$  then a lower  $H_w$  shall be used to recalculate  $Q_p$  and  $Q_{sf}$ . The designer shall refine the water surface level  $H_w$  until  $Q_c = Q_p + Q_{sf}$ .

**Table 4: Entrance Loss Coefficients**  
Paragraph 4.1.8

Design of entrance	Entrance loss coefficients $k_e$
<b>Pipe culverts</b>	
Pipe projecting from fill:	
square cut end	0.5
socket end	0.2
Headwall with or without wing walls	
square end	0.5
socket end	0.2
Pipe mitred to conform with fill slope	
precast end	0.5
field cut end	0.7
<b>Box culverts</b>	
No wing walls, headwall parallel to embankment	
square edge on three edges	0.5
three edges rounded to 1/12 of barrel dimensions	0.2
Wing walls at 30° to 75° to barrel	
square edge at crown	0.4
crown rounded to 1/12 of culvert height	0.2
Wing walls at 10° to 30° to barrel	
square edge to crown	0.5
Wing walls parallel (extension of sides)	
square edge at crown	0.7

**4.1.11** The secondary flow  $Q_{sf}$  shall be determined from a) or b) as appropriate.

a) Where the flow over the secondary flow point operates as a weir (such as a flow over a culvert headwall, kerb, footpath, crown in the road, driveway entrance, etc.) then  $Q_{sf}$  shall be determined by:

$$Q_{sf} = 1.6 B H_{sf}^{3/2}$$

where

$$Q_{sf} = \text{secondary flow (m}^3/\text{s)}.$$

$B$  = width (metres) of the *secondary flow path* at the point of overflow over the weir, from the channel to the *secondary flow path*.

$H_{sf}$  = secondary flow water depth (metres), being the difference between the assumed headwater surface level

$H_w$  and the average ground level over width  $B$ , at the point of overflow into the *secondary flow path*.

b) Where the flow over the secondary flow point operates as a pipe or channel flow (such as directly down a side channel or pipe) then  $Q_{sf}$  shall be determined by:

$$Q_{sf} = A_{sf} R_{sf}^{2/3} S_{sf}^{1/2} n_{sf}^{-1}$$

where

$$Q_{sf} = \text{secondary flow (m}^3/\text{s)}.$$

$A_{sf}$  = cross-sectional area (m<sup>2</sup>) of the flow down the secondary flow channel or pipe.

$$R_{sf} = \text{hydraulic radius (m)} = A_{sf} / P_{sf}$$

$P_{sf}$  = wetted perimeter (m) of the cross-section of the secondary flow in the channel or pipe.

$S_{sf}$  = slope of the ground (vertical fall/ horizontal distance) along the *secondary flow path* at the overflow point.

$n_{sf}$  = Manning's 'n' (roughness coefficient). See Table 3.

**4.2 Secondary flow from an open water course upstream of the site**

**4.2.1** Where the surface run-off from a catchment at a possible overflow point  $Q_c$  is flowing at subcritical flow, i.e. where:

$$v_c \leq (gH_c)^{0.5}$$

where

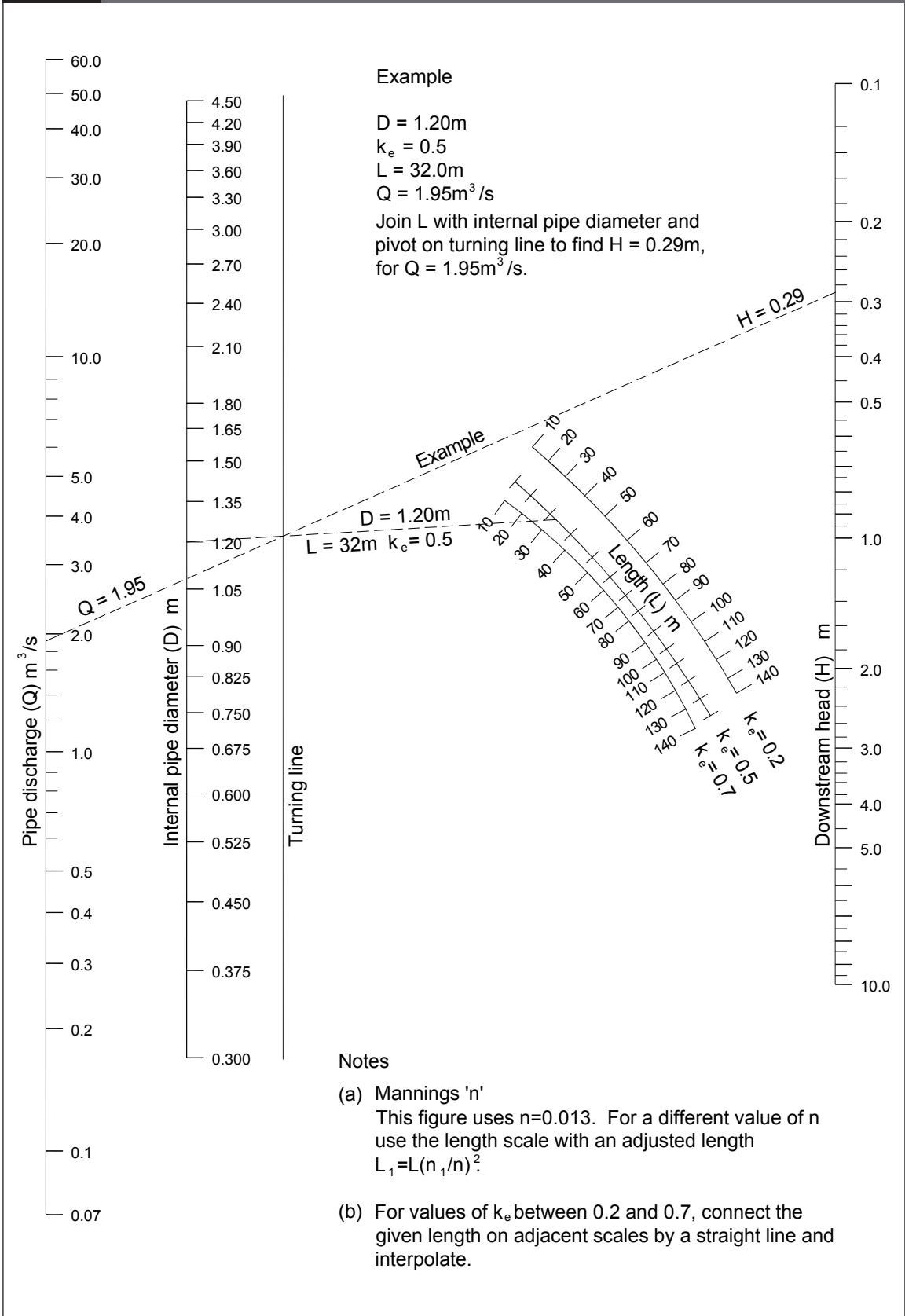
$v_c$  = velocity (m/s) in the stream at the possible overflow point.

$H_c$  = depth of flow (m) in the stream at the possible overflow.

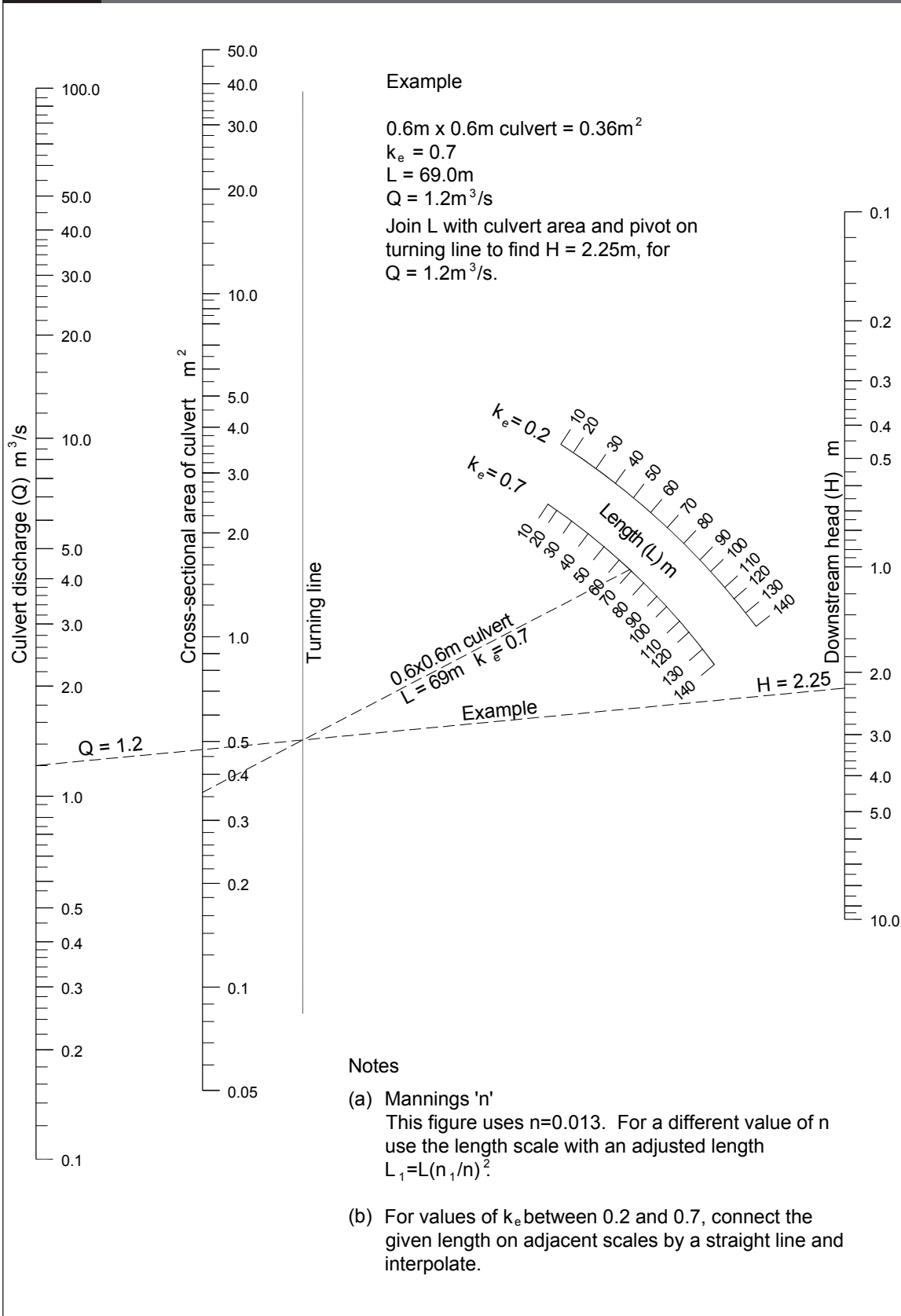
then an assessment of secondary flow  $Q_{sf}$  shall be made by the procedure set out below. If the surface run-off from the catchment, at the possible overflow point  $Q_c$  is flowing at super critical flow (i.e.  $v_c > (gH_c)^{0.5}$ ) then specific design shall be used to assess  $Q_{sf}$ .

*Continued on page 27*

**Figure 10: Downstream Head for Circular Pipe Culverts**  
Paragraph 4.1.9



**Figure 11: Downstream Head for Box Culverts**  
Paragraph 4.1.9



Secondary flow from an open water course upstream of the site shall be determined by an iterative process similar to that described in Paragraph 4.1.10 for pipes and culverts but using the formula:

$$Q_c = Q_{strm} + Q_{sf}$$

where

$Q_c$  = surface run-off from catchment upstream of possible overflow point ( $m^3/s$ ),

$Q_{strm}$  = that portion of surface water run-off ( $m^3/s$ ) flow down the stream channel downstream of the possible overflow point, and

$$Q_{strm} = R_{strm}^{2/3} S_{strm}^{1/2} n_{strm}^{-1} A_{strm}$$

where  $R_{strm}$  and  $A_{strm}$  are determined from an assumed water surface and

$R_{strm}$  = hydraulic radius of stream (m) downstream of the possible overflow point.

$S_{strm}$  = slope of stream (vertical fall/horizontal distance) downstream of the possible overflow point.

$n_{strm}$  = Manning's 'n' (roughness coefficient). See Table 3.

$A_{strm}$  = cross-sectional area of the stream ( $m^2$ ), and

$$Q_{sf} = R_{sf}^{2/3} S_{sf}^{1/2} n_{sf}^{-1} A_{sf}$$

where  $R_{sf}$  and  $A_{sf}$  are determined from the secondary flow depth being the difference between the assumed water surface and the ground level at the point of overflow into the *secondary flow path*.

The designer shall refine the level of water surface until  $Q_c = Q_{strm} + Q_{sf}$ .

### 4.3 Secondary flow from site to downstream drainage system

**4.3.1** The secondary flow estimated to arrive on the site shall be directed into the *surface water* drainage system designed for the site. The height of the secondary flow shall be used as a basis for determining the *building* floor level necessary to comply with the requirements of NZBC E1.3.2.

The level of the floor shall be set at the height of the secondary flow plus an allowance for freeboard. The freeboard shall be:

- 500 mm where *surface water* has a depth of 100 mm or more and extends from the *building* directly to a road or car park, other than a car park for a single dwelling.
- 150 mm for all other cases.

#### COMMENT:

The 500 mm freeboard allows for waves generated by vehicles. Such waves will not be sustained unless there is at least 100 mm depth of water and an unobstructed path from the point where the wave is generated to the *building*.

## 5.0 Energy Losses Through Structures

**5.0.1** Hydraulic design shall make allowance for energy losses at *access chamber* structures where a change in direction of the flow occurs. An additional fall shall be provided through the *access chamber* to allow for these losses. This fall  $H_L$  (m) is in addition to the fall produced by the gradient of the pipe line, and shall be calculated using the formula:

$$H_L = Kv^2/2g$$

where

$K$  = energy loss coefficient for change in direction determined from Figure 12.

$v$  = flow velocity (m/s).

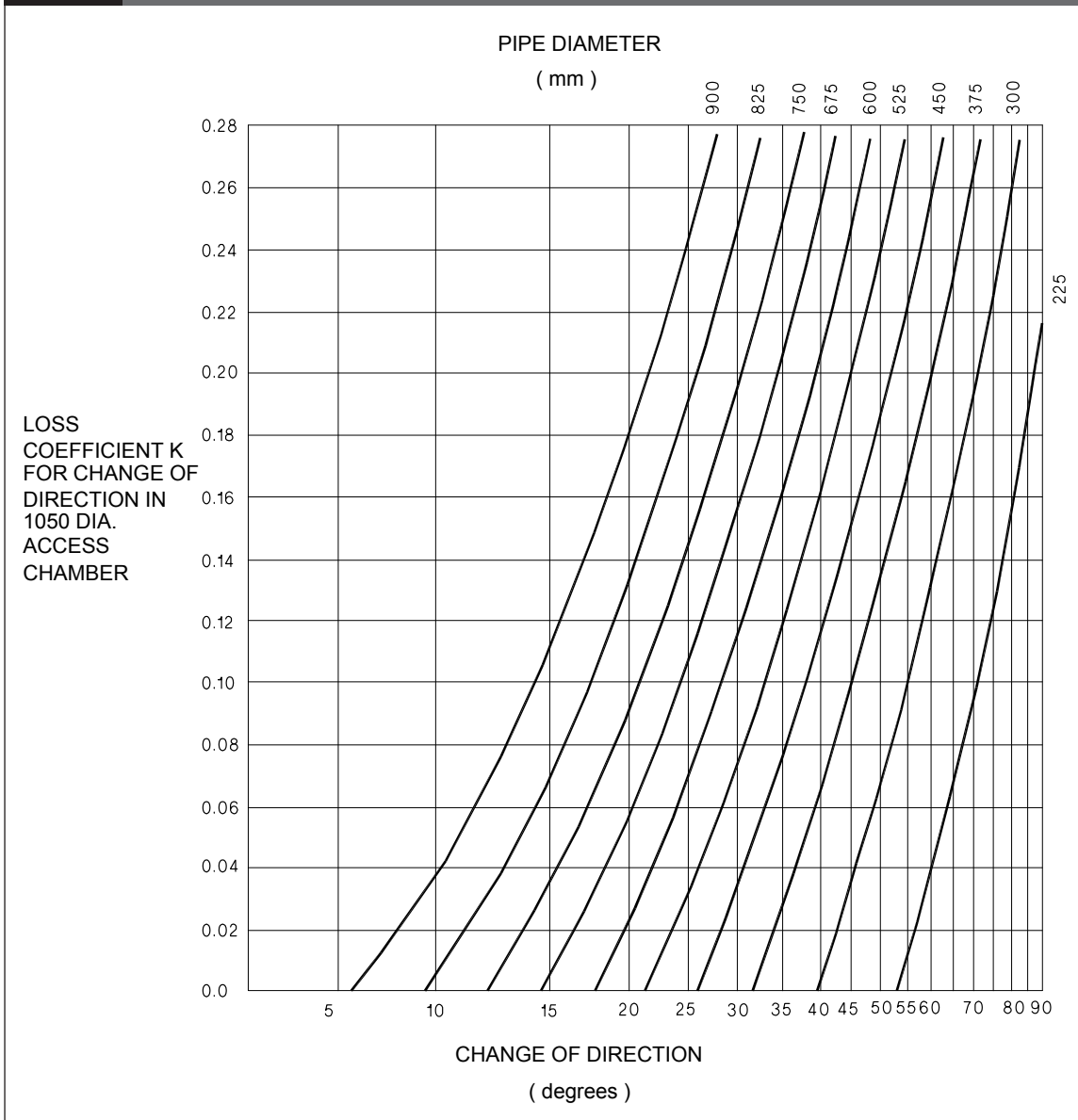
$g$  = gravitational acceleration =  $9.8 \text{ m/s}^2$ .

**5.0.2** In cases where a reduction in *drain* size is justified by a large increase in gradient, an additional head loss of  $0.5 v_e^2/2g$  shall be allowed for ( $v_e$  = exit velocity). Such reductions in size are only permissible where the exit pipe has an internal diameter of 300 mm or greater.

## 6.0 Minimum Velocity

**6.0.1** A *drain*, shall have a minimum flow velocity of 0.6 m/s when *sumps* are incorporated and 0.9 m/s when no *sumps* are used.

**Figure 12: Energy Loss Coefficient**  
Paragraph 5.0.1





## 7.0 Outfall Protection

**7.0.1** Unless more stringent requirements are imposed by the *network utility operator* the following shall apply to the flow discharging from the site into the *outfall*:

- a) The exiting velocity shall not exceed the values given in Table 5, and
- b) Where the *outfall* is a pipe, culvert or stream the volume discharged shall not exceed 20% of the flow in the *outfall* immediately upstream of the discharge point.

**COMMENT:**

- 1. The *outfall*, be it a pipe, culvert, stream, lake or the sea, needs to be protected from erosion or scour to meet the requirements of Clause E1.3.3 (e).
- 2. If exit velocities exceed those given in Table 5 protective structures to dissipate the energy and reduce the velocities are required. These require specific design which is outside the scope of this document.
- 3. Discharge to some *outfalls* will require a resource management consent.

**Table 5: Maximum Exit Velocities of Flow from Pipes and Culverts Discharging to Outfalls**  
Paragraph 7.0.1

Outfall material	Velocity m/s
Precast concrete pipes to NZS 3107	8.0
Precast concrete culverts	8.0
In-situ concrete and hard packed rock (300 mm minimum)	6.0
Beaching or boulders (250 mm minimum)	5.0
Stones (100-150 mm)	2.5 – 3.0
Grass covered surfaces	1.8
Stiff, sandy clay	1.3 – 1.5
Coarse gravel	1.3 – 1.8
Coarse sand	0.5 – 0.7
Fine sand	0.2 – 0.5

## 8.0 Drain Leakage Tests

**8.0.1** The materials and workmanship used in *surface water drains* shall pass one of the following tests:

- a) Water test.
- b) Low pressure air test.
- c) High pressure air test.

**8.0.2** Regardless of test method the pipeline to be tested shall be sealed with suitably restrained plugs (at both ends and at all branch connections) and, where the pipe material is porous (such as ceramic or concrete), it shall be soaked for 24 hours prior to testing.

**COMMENT:**

Soaking is necessary as porous pipes can absorb water or transmit air through their walls.

### 8.1 Water test

- a) Fill pipe with water, ensuring all air is expelled.
- b) Top up water to test head level. The minimum head shall be 1.5 m above the top of the pipe or ground water level whichever is the higher. The maximum head at the lower end of the pipeline shall not exceed 6.0 m.
- c) Leave for 30 minutes then measure water loss.
- d) The pipeline is acceptable if water loss does not exceed 2 ml per hour, per mm of internal diameter, per m of pipeline length.

### 8.2 Low pressure air test

- a) Introduce air to the pipeline till a pressure of 300 mm water gauge is reached. (This may be measured by a manometer such as a 'U' tube, connected to the system.)
- b) Wait until the air temperature is uniform. (Indicated by the pressure remaining steady.)
- c) Disconnect the air supply.
- d) Measure pressure drop after 5 minutes.
- e) The pipeline is acceptable if the pressure drop does not exceed 50 mm.

**COMMENT:**

1. The low pressure air test is highly susceptible to temperature fluctuations during the test period. A 1°C change during the 5 minute test period will cause a pressure change of 30 mm water gauge or 60% of the permitted change.
2. Failure to soak ceramic and concrete pipes can cause highly variable results.

**8.3 High pressure air test**

- a) Pressurise pipeline to 25 kPa.
- b) Wait at least 2 minutes to ensure temperature stabilisation.
- c) Disconnect air supply.
- d) Measure the time taken (minutes) for the pressure to drop to 17 kPa.
- e) The pipeline is acceptable if the time taken exceeds that given for the appropriate pipe size in Table 6.

**Table 6: Time For Pressure Drop Versus Internal Pipe Diameter**  
Paragraph 8.3 e)

Internal pipe diameter (mm)	Time for permissible pressure drop (minutes)
90	3
100	3
150	4
225	6

**9.0 Disposal to Soak Pit**

**9.0.1** Where the collected *surface water* is to be discharged to a soak pit, the suitability of the natural ground to receive and dispose of the water without causing damage or nuisance to neighbouring property, shall be demonstrated to the satisfaction of the *territorial authority*.

**COMMENT:**

Means of demonstrating the suitability of the ground are outside of the scope of this Verification Method. Disposal of *surface water* to a soak pit may also require a resource management consent.

**9.0.2** Field testing of soakage shall be carried out as follows:

- a) Bore test holes of 100 mm to 150 mm diameter to the depth of the proposed soak pit. If groundwater is encountered in the bore test hole then this depth shall be taken as the depth of the soak pit.
- b) Fill the hole with water and maintain full for at least 4 hours, (unless the soakage is so great that the hole completely *drains* in a short time).
- c) Fill the hole with water to within 750 mm of ground level, and record the drop in water level against time, at intervals of no greater than 30 minutes, until the hole is almost empty, or over 4 hours, whichever is the shortest.
- d) Plot the drop in water level against time on a graph, and the soakage rate in mm/hr is determined from the minimum slope of the curve. If there is a marked decrease in soakage rate as the hole becomes nearly empty, the lower rates may be discarded and the value closer to the average can be adopted.

**9.0.3** The soak pit shall be designed utilising soakage and storage in accordance with 9.0.5 and 9.0.6 to ensure that *surface water* is discharged without overflowing. The rainfall intensity used in the design of the soak pit shall be that of an event having a duration of 1 hour and a 10% probability of occurring annually. Either local rainfall intensity curves produced by the *territorial authority* or rainfall frequency duration information produced by NIWA shall be used to determine the rainfall intensity.

**COMMENT:**

This Verification Method does not cover the design of soak pits with overflows discharging to *outfalls*. Such soak pits are often provided to retain water until peak flows in the *outfall* have passed and it is normally considered sufficient to design them for an event having a 10 minute duration and a 10% probability of occurring annually.

**9.0.4** The soak pit shall comprise either a rock filled hole (see Figure 13 (a)) or a lined chamber (see Figure 13 (b)). Both of these options shall be enclosed in filter cloth

complying with AS 3706.1. The filter cloth shall have a mass per unit area of 140 grams/m<sup>2</sup> and a minimum thickness of 0.45 mm.

**9.0.5** The volume of storage required in the soak pit,  $V_{stor}$  (m<sup>3</sup>), shall be calculated by:

$$V_{stor} = R_c - V_{soak}$$

where

$R_c$  = run-off discharged from catchment to soak pit in 1 hour (m<sup>3</sup>).

$V_{soak}$  = volume disposed of by soakage in 1 hour (m<sup>3</sup>).

and

$$R_c = 10CIA$$

where

$C$  = run-off coefficient (see Table 1).

$I$  = rainfall intensity (mm/hr) based on 1 hour duration of an event having a 10% probability of occurring annually.

$A$  = area (hectares) of the catchment discharging to the soak pit.

and

$$V_{soak} = A_{sp}S_r/1000$$

where

$A_{sp}$  = area of the base of the soak pit (m<sup>2</sup>).

$S_r$  = soakage rate (mm/hr) determined from 9.0.2.

Amend 5  
Jul 2001

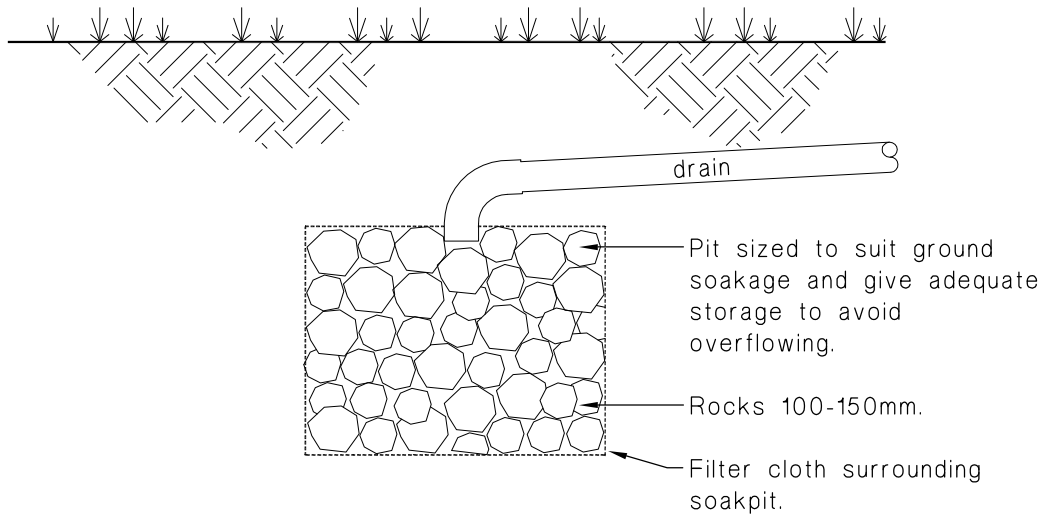
**COMMENT:**

Generally where the test results show a soakage rate of greater than 500 mm/hour, soakage rather than storage will be the main mechanism to remove the water. Where the soakage rate is significantly less than 500 mm/hour, storage will become the dominant factor. Intermediate soakage rates will require a design utilising both in the proportions necessary to ensure the water will dissipate before it overflows from the pit.

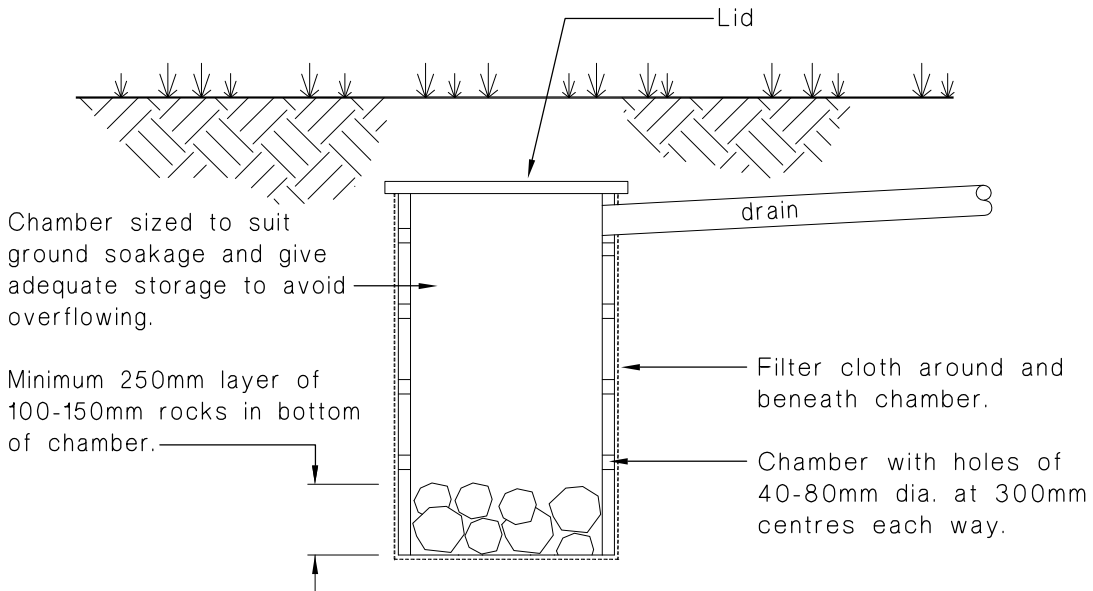
**9.0.6** Where the soak pit comprises a rock filled hole (see Figure 13 (a)) then the volume of the hole shall be calculated as  $V_{stor}$  divided by 0.38.

Amend 10  
Jan 2017

**Figure 13: Soak Pit for Surface Water Disposal**  
Paragraph 9.0.4



(a) Rock soak pit



(b) Chamber soak pit

# Acceptable Solution E1/AS1

## 1.0 Limitations of the Solution

**1.0.1** This Acceptable Solution is limited to *buildings* and *sitework* having a catchment area of no more than 0.25 hectares and which are:

- a) Free from a history of flooding,
- b) Not adjacent to a watercourse,
- c) Not located in low lying area, and
- d) Not located in a *secondary flow path*.

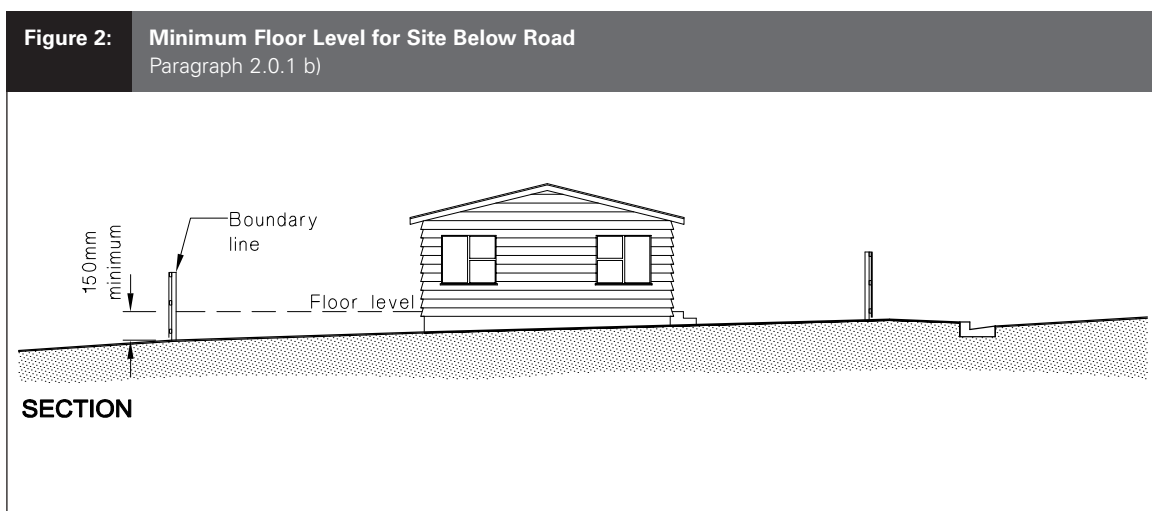
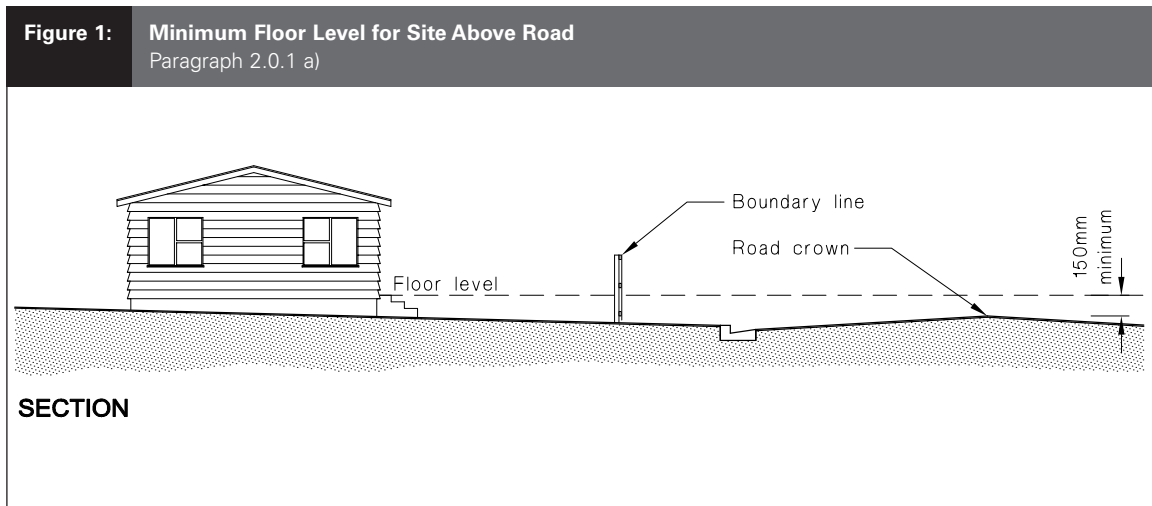
**COMMENT:**

Boundary fences and other site development must not significantly hamper the flow of *surface water* from the site.

## 2.0 Minimum Acceptable Floor Level

**2.0.1** Suspended floors and slabs on ground shall be at least 150 mm above the finished level of the surrounding ground immediately adjacent to the *building*, and:

- a) For sites level with or above the road, no less than 150 mm above the road crown on at least one cross-section through the *building* and roadway (see Figure 1).
- b) For sites below the road, no less than 150 mm above the lowest point on the site boundary (see Figure 2).



**3.0 Drainage System Materials and Construction**

**3.1 Materials**

**3.1.1** Pipe materials shall comply with the standards given in Table 1.

**Table 1: Acceptable Pipe Materials**  
Paragraphs 3.1.1 and 3.9.2

Concrete	AS/NZS 4058
Vitrified clay	AS 1741
Steel	NZS 4442 or AS 1579
Ductile iron	AS/NZS 2280
PVC-U	AS/NZS 1260 or AS/NZS 1254
Polyethylene	AS/NZS 4130 or AS/NZS 5065
Polypropylene	AS/NZS 5065

Amend 7  
Sep 2010

Amends  
8 and 11

**3.2 Sizing of drains**

**3.2.1** *Drains* shall be of sufficient size and gradient to transport *surface water* from the site, and be capable of handling the rainfall calculated to fall on roof and paved areas of the site during a storm with a 10% probability of occurring annually. No *drain* shall have an internal diameter of less than 85 mm.

Amend 1  
Sep 1993

**3.2.2** Figure 3 provides a method for selecting the correct pipe size for a calculated modified catchment area, given as:

Modified catchment area = 0.01 A<sub>I</sub>,

where

A = area being drained comprising plan roof area (m<sup>2</sup>) plus paved area (m<sup>2</sup>). Paved area includes paving blocks, concrete, asphalt or metalised surfaces.

I = rainfall intensity for a storm with a 10% probability of occurring annually and a 10 minute duration (mm/hr).

The rainfall intensity (I) shall be obtained from the *territorial authority* or from the Table in Appendix A.

**COMMENT:**

Where there are differences between the design rainfall intensities obtained from the above sources for a particular location, the most conservative rainfall intensity should be used for design calculations.

Amend 11  
Nov 2020

Territorial Authorities may refer to any available Regional Council rainfall data to establish design rainfall intensities for their city or district.

Amend 11  
Nov 2020

**3.2.3** The modified catchment area method is only suitable for the combination of pipe sizes, gradients and areas indicated in Figure 3. For other combinations specific design is required.

**3.3 Alignment and gradient of drains**

**3.3.1** *Drains* shall be laid on a uniform line and gradient between points of access (see Paragraph 3.7). The change in direction of a *drain* shall not exceed 90° at any point, and where practical should be kept to less than 45° as illustrated in Figure 4.

**3.3.2** Where two *drains* intersect, the directions of flow as shown in Figure 5 shall be at an angle of 60° or less.

**3.4 Minimum gradients**

**3.4.1** Minimum acceptable gradients for *surface water drains* are given in Table 2.

**Table 2: Minimum Gradients**  
Paragraph 3.4.1

Drain internal diameter	Minimum gradient
85 mm	1 in 90
100 mm	1 in 120
150 mm	1 in 200
225 mm	1 in 350

Amend 1  
Sep 1993

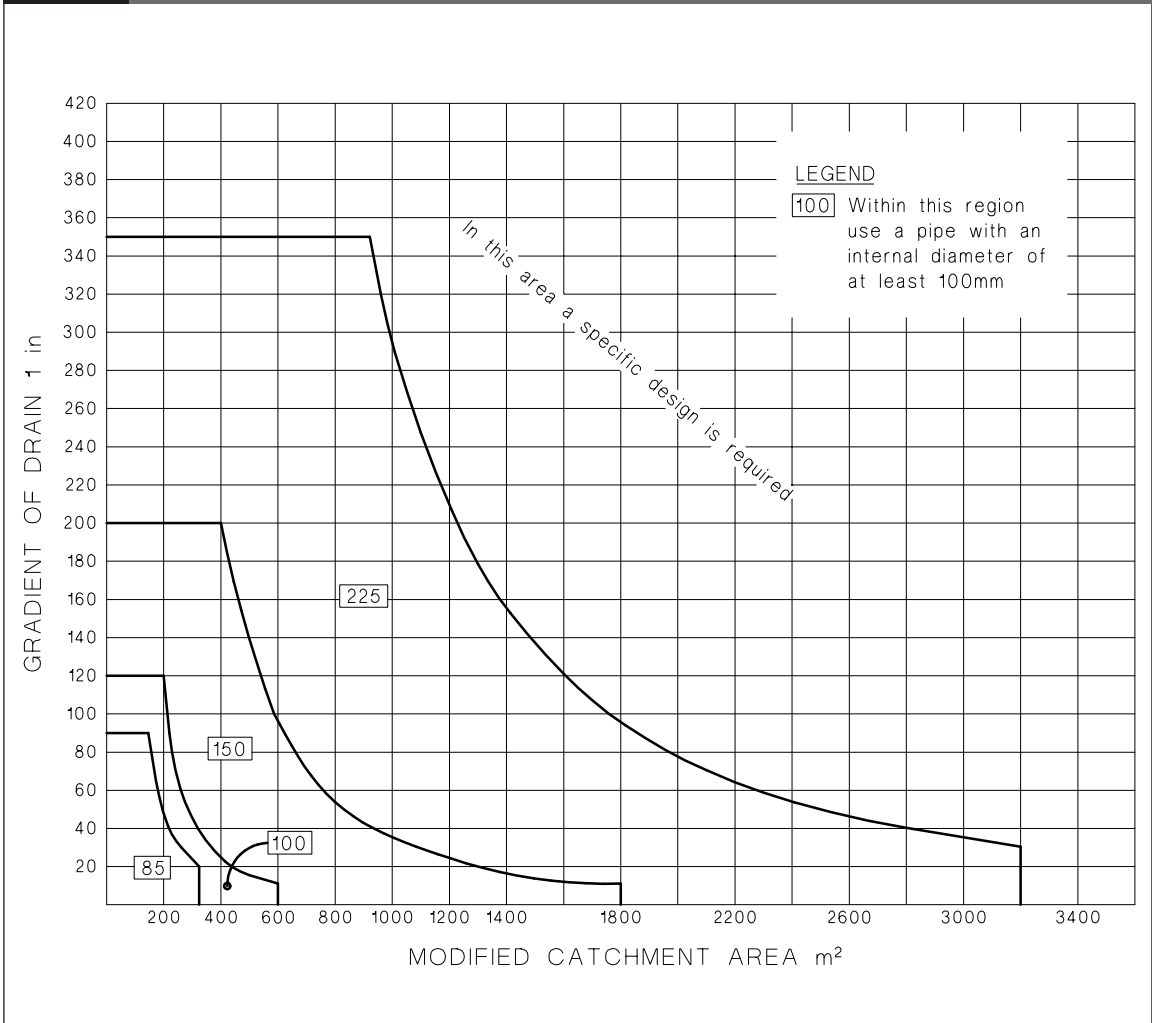
**3.4.2 Restricted fall to outlet**

Where the *surface water sewer*, road channel or other *outfall* is at too high a level to allow the gradient required by Table 2, the bubble-up chamber system shown in Figures 6 and 7 may be used provided that:

- a) The ground level adjacent to any downpipe discharging to the bubble-up chamber is at least 150 mm higher than the level of the top of the chamber outlet.
- b) The connections between the *drain* and downpipes are sealed.

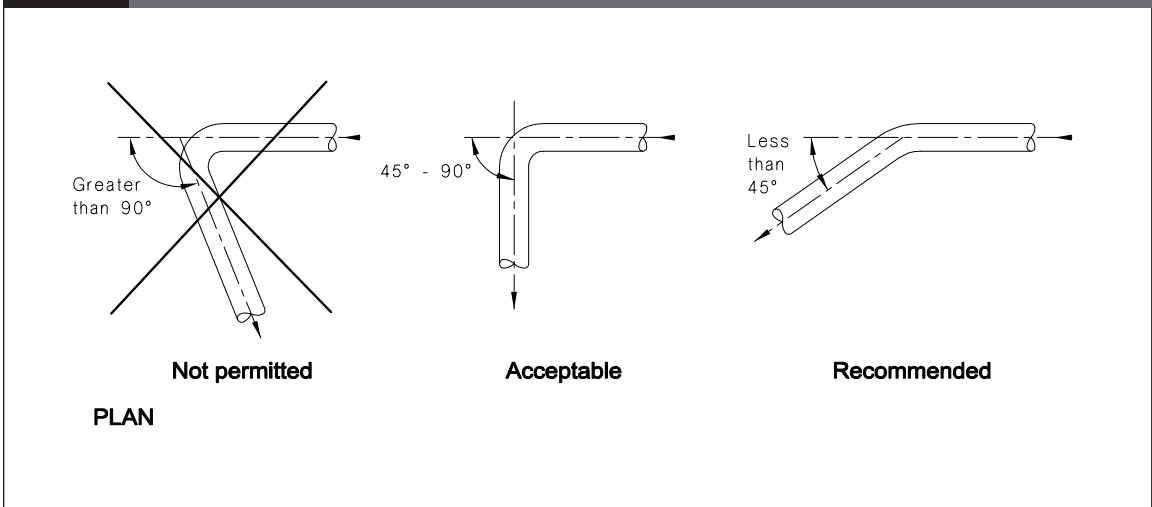
*Continued on page 36*

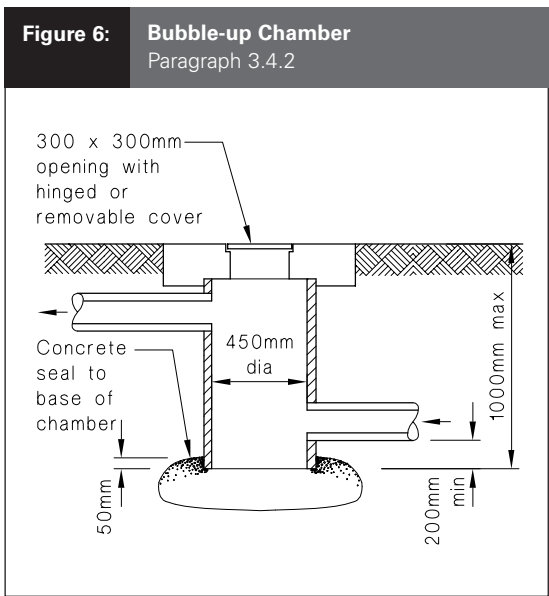
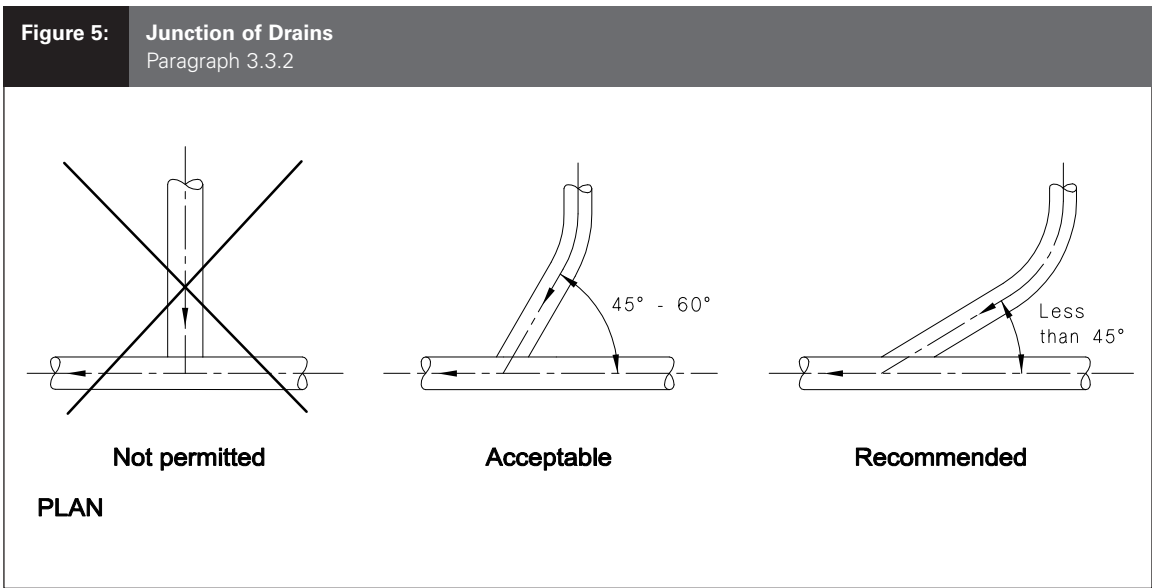
**Figure 3: Sizing of Surface Water Drains**  
Paragraphs 3.2.2 and 3.2.3



Amend 1  
Sep 1993

**Figure 4: Changes of Direction**  
Paragraph 3.3.1





c) The total chamber depth does not exceed 1.0 m.

**COMMENT:**

The bubble-up chamber allows the water to be discharged through pipes laid at the allowable minimum gradients, and for the convenient collection and removal of any silts or debris which might enter the system.

**3.5 Jointing of drains**

**3.5.1** All joints in *drains* shall be watertight and prevent the infiltration of groundwater and the intrusion of tree roots.

**3.5.2** Acceptable jointing methods and the relevant standards are given in Table 3. Jointing of *drains* shall be subject to the tests called for in Paragraph 3.8.

**3.5.3** Where a *drain* consists of concrete, ceramic, vitrified clay or rubber ring jointed steel or uPVC, a flexible joint shall be installed within 225 mm of the outside wall of any *access chamber* or *inspection chamber*, but outside the line of the base (see Figures 11 and 12).

**COMMENT:**

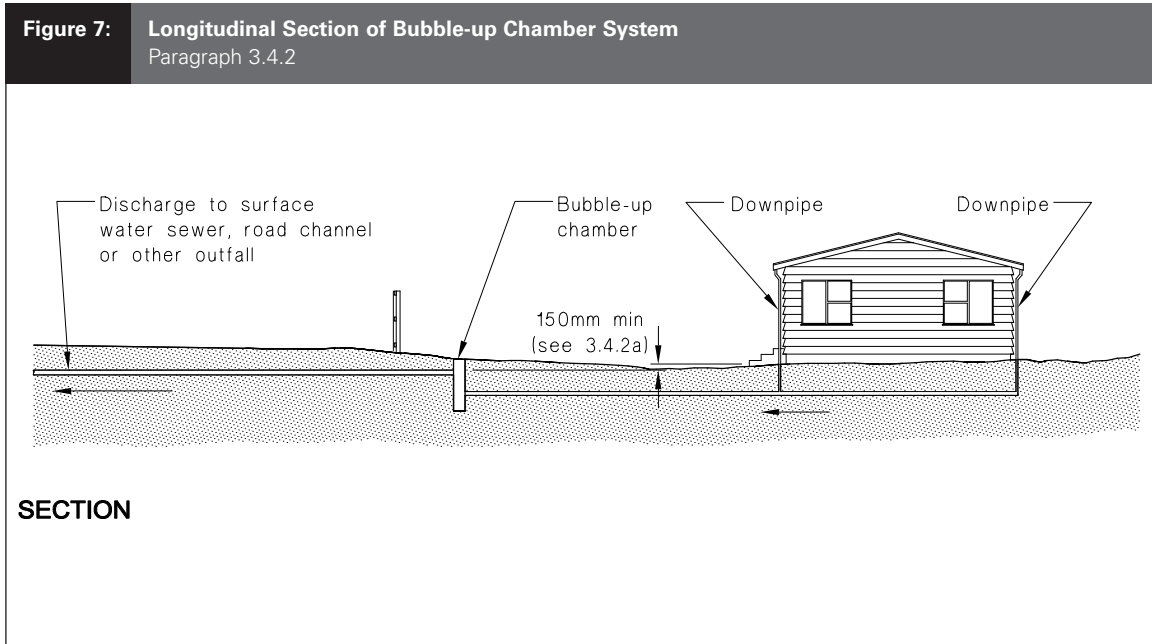
This allows for differential settlement between the *access chamber*, or the *inspection chamber*, and the pipeline while minimizing damage to the pipeline.

**3.6 Surface water inlets to drains**

**3.6.1** All *surface water*, except that collected directly from a roof, shall enter the *drain* via a *sump* which has:

- a) A grating, hinged or removable for maintenance access. The grating shall comprise at least 35% openings. The smaller dimension of any individual opening shall not exceed 35 mm,
- b) Capacity at the bottom for settlement of silt and debris, and
- c) A submerged (or trapped) outlet which prevents floatable solids entering the *drain*.





**Table 3: Acceptable Jointing Methods**  
Paragraph 3.5.2

Pipe material	Jointing method	Standard
Concrete	Elastomeric ring	AS 1646
Steel	Elastomeric ring, welded or flanged	NZS 4442, BS EN 1759.1
Ductile iron	Elastomeric ring or flanged	AS/NZS 2280
PVC-U	Electromeric ring or solvent welded	AS 1646, AS/NZS 2032, AS/NZS 1254
Polyethylene	Heat welded or flanged	AS/NZS 2033
Polypropylene		AS/NZS 2566.2

Amend 7  
Sep 2010

Amend 8  
Oct 2011

**COMMENT:**

For compliance with this Acceptable Solution, *surface water* collected directly from a roof should discharge directly to a *drain*, and should not enter the *drain* via a *sump*.

Amend 11  
Nov 2020

**3.6.2** Two different *sumps* are shown in Figures 8 and 9. The *sump* shown in Figure 8 is suitable for an area of up to 4500/l m<sup>2</sup> and the *sump* illustrated by Figure 9 is suitable for an area up to 40,000/l m<sup>2</sup>, where l is the rainfall intensity for a storm with a 10% probability of occurring annually. (See Paragraph 3.2.2.)

**COMMENT:**

Example sump selection calculation for a site in Manukau, Auckland.  
 I = 93 mm/hr (obtained from Appendix A)  
 Maximum catchment area for a Type-one sump in Manukau, Auckland: 4,500 / 93 = 48.4 m<sup>2</sup>.  
 Maximum catchment area for a Type-two sump in Manukau, Auckland: 40,000 / 93 = 430.1 m<sup>2</sup>.

Amend 12  
Nov 2023

**3.7 Access for maintenance**

**3.7.1** Access for maintenance shall be provided on all *drains*. Access is to be achieved via an *inspection point*, *rodding point*, *inspection chamber* or *access chamber*, complying as appropriate with Figures 10, 11 or 12.

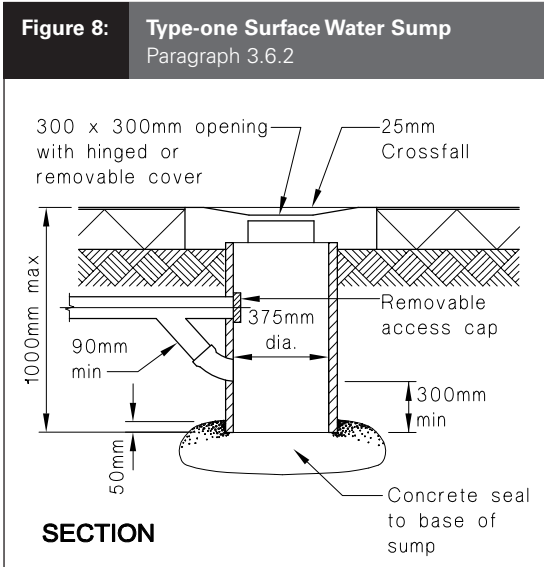
**COMMENT:**

*Rodding points* rather than *inspection points* are preferred in landscaped or sealed areas.

**3.7.2** Points of access shall be spaced at no further than:

- a) 50 m where *rodding points* are used.
- b) 100 m where *inspection points*, *inspection chambers* or *access chambers* are used.

Amend 1  
Sep 1993



**3.7.3** Points of access are required at:

- a) Changes in direction of greater than 45°,
- b) Changes in gradient of greater than 45°, and
- c) Junctions of drains other than a drain, serving a single downpipe, that is less than 2.0 m long.

**3.7.4** Inspection chambers or access chambers (see Figures 11 and 12) shall be provided where changes in both gradient and direction occur and where either is greater than 22.5°.

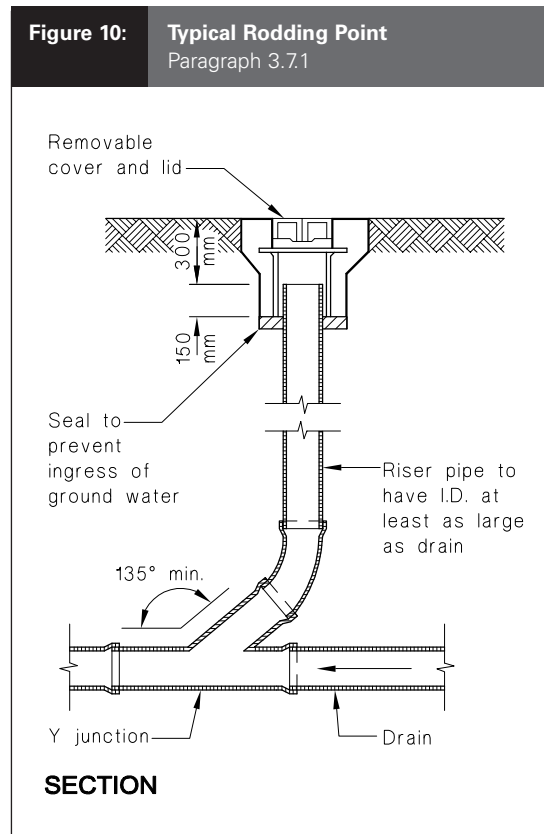
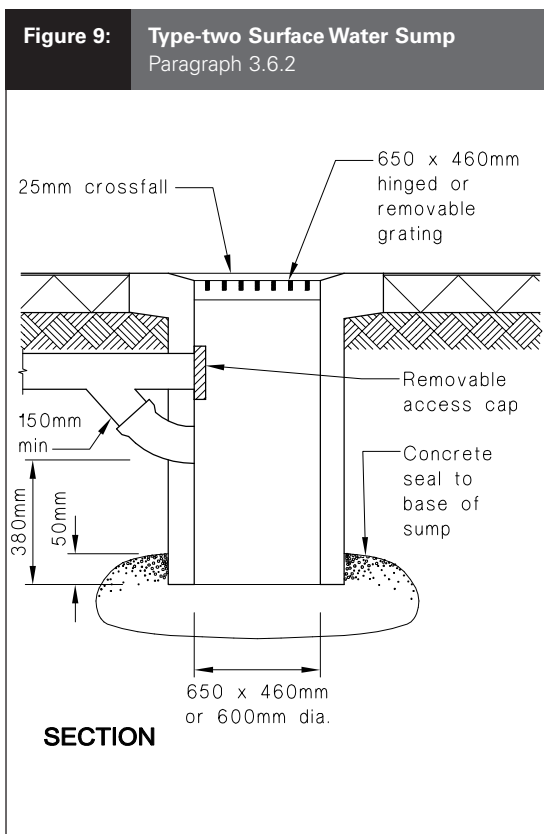
**3.7.5** Where the depth to the invert of the drain exceeds 1.0 m, an inspection chamber is not acceptable and an access chamber shall be used.

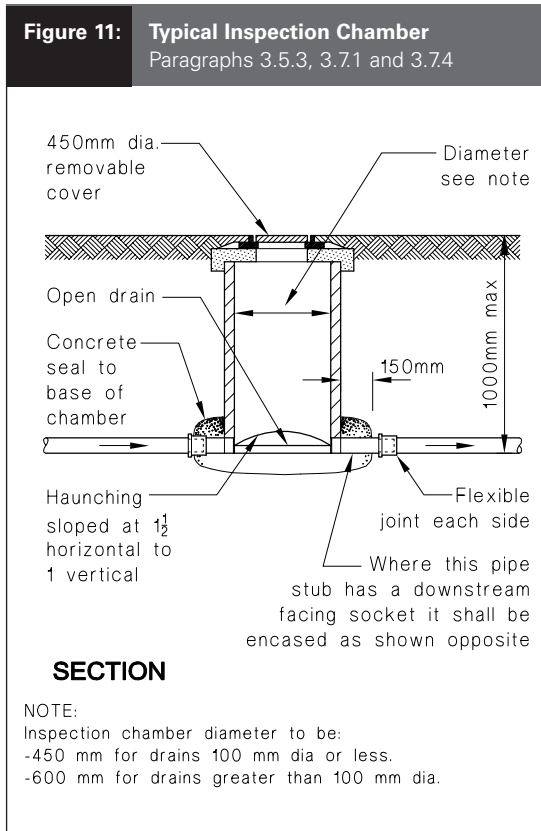
**3.7.6 Drain under buildings**

Any drain laid under a building shall be run in a straight line from one side to the other.

**3.7.7** Access to a drain laid under a building shall be provided immediately outside the building. These points of access shall be located within 2.0 m of an exterior wall.

**3.7.8** Under a building the only acceptable inlets to a drain are from sealed roof-water downpipes. Access shall be provided to the drain via a sealed access point in the downpipe immediately above ground floor level.





### 3.8 Testing of drains

**3.8.1** Surface water drains shall be capable of passing one of the tests described in E1/VM1 Paragraph 8.0.

Amend 5  
Jul 2001

### 3.9 Bedding and backfilling

#### 3.9.1 General

NZBC B1 requires all *drains* be constructed to withstand the combination and frequency of loads likely to be placed upon them without collapse, undue damage, undue deflection or undue vibration. In addition, *adequate* support needs to be provided to prevent gradients becoming less than those required by Paragraph 3.4.1 as a result of:

- a) Differential settlement, or
- b) Deflection of an unsupported span.

#### 3.9.2 Bedding and backfilling

Figure 13 gives acceptable methods for the bedding and backfilling of the drainage pipes listed in Table 1 except where:

Amend 12  
Nov 2023

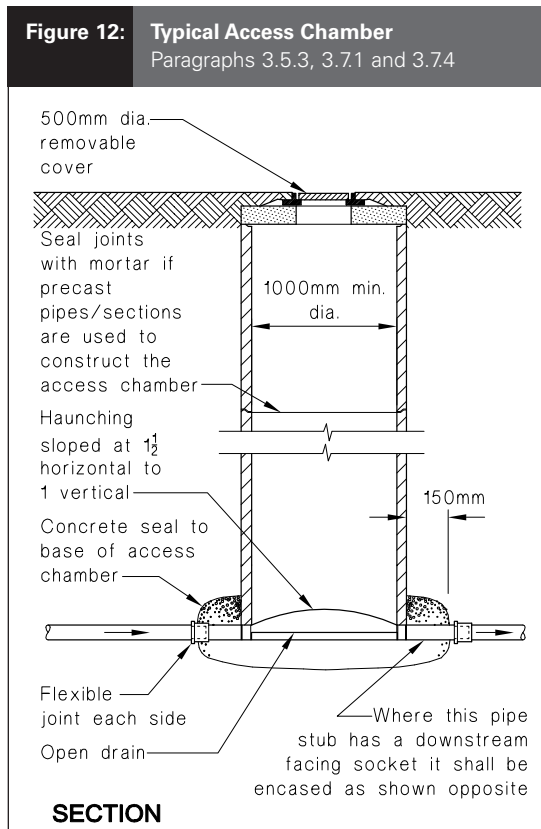
- a) The trench is located within or above peat, or
- b) Scouring of the trench is likely due to unstable soils, or
- c) The horizontal separation between any *building* foundation and the underside of the pipe trench is less than that required by Paragraph 3.9.7, or
- d) The cover H to the pipe is more than 2.5 m.

#### 3.9.3 Trench slope

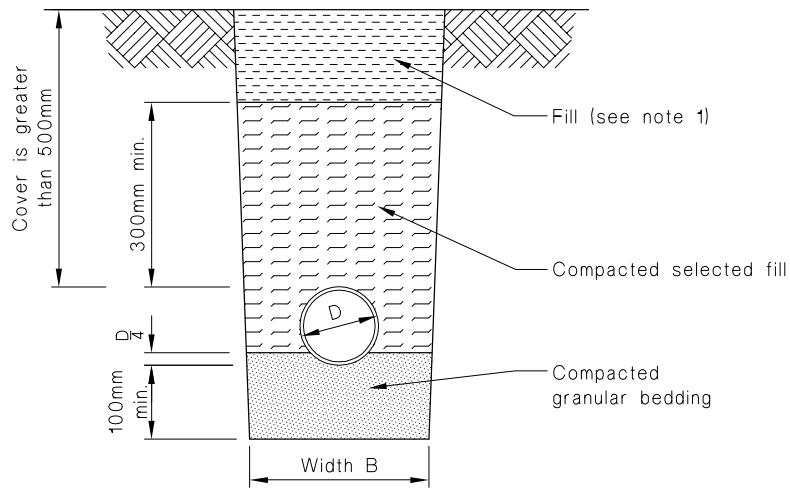
Where the slope of the trench is 1 in 8 or greater, anti-scour blocks shall be provided. These anti-scour blocks shall be:

- a) Constructed from 150 mm thick concrete (17 MPa),
- b) Keyed into the sides and floor of the trench by 150 mm,
- c) Extended to 300 mm above the *drain* or to ground level where the *drain* cover is less than 300 mm, and

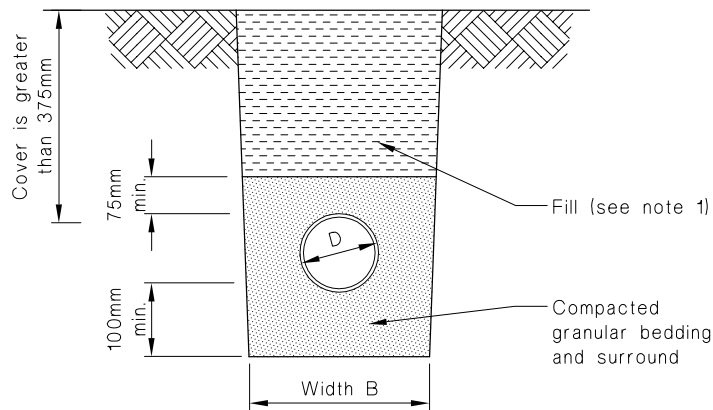
Continued on page 41



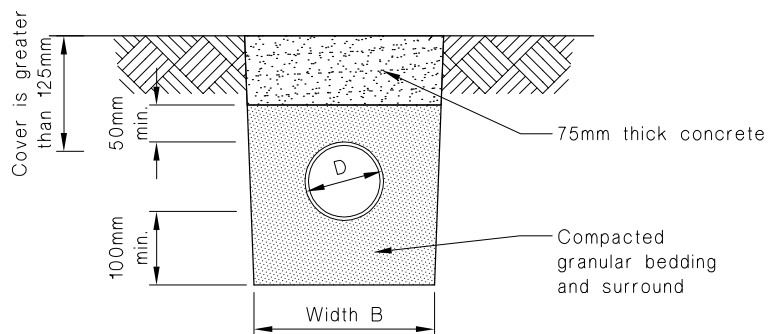
**Figure 13: Bedding and backfilling**  
Paragraphs 3.9.2, 3.9.4 and 3.9.5



**(a) Cover greater than 500mm**



**(b) Cover greater than 375mm**



**(c) Cover greater than 125mm**

**NOTE:**

1. Fill shall be:
  - Ordinary fill where drains are located below gardens and open country.
  - Compacted selected fill where the drains are located below residential driveways and similar areas subjected to light traffic.

Amends 1 and 11

Amend 1 Sep 1993

Amends 1 and 11

Amend 1 Sep 1993

Amends 1 and 11

Amend 1 Sep 1993

- d) Spaced at:
- i) 7.5 m centres for trench slopes between 1 in 8 and 1 in 5, or
  - ii) 5.0 m centres for trench slopes greater than 1 in 5.

**COMMENT:**

The anti-scour blocks partition off the trench and prevent ground or *surface water* running along the trench and causing scouring.

**3.9.4 Trench width**

The width B of the trench shall be no less than the pipe diameter D plus 200 mm. Trench width at the top of the pipe shall be no more than 600 mm unless the pipe(s) in the trench are covered with concrete, as shown in Figure 13 (c).

**3.9.5 Acceptable materials**

Acceptable fill materials shown in Figure 13 are:

- a) Bedding material of clean granular non-cohesive material with a maximum particle size of 20 mm, or
- b) Selected compacted fill of any fine-grained soil or granular material which is free from topsoil and rubbish and has a maximum particle size of 20 mm, or
- c) Ordinary fill which may comprise any fill or excavated material.

**3.9.6 Placing and compacting**

- a) Granular bedding and selected fill shall be placed in layers of no greater than 100 mm loose thickness and compacted.
- b) Up to 300 mm above the pipe, compaction shall be by tamping by hand using a rod with a pad foot (having an area of  $75 \pm 25$  mm by  $75 \pm 25$  mm) over the entire surface of each layer to produce a compact layer without obvious voids.
- c) More than 300 mm above the pipe, compaction shall be by at least four passes of a mechanical tamping foot compactor (whacker type) with a minimum weight of 75 kg.

**3.9.7 Proximity of trench to building**

For light timber frame and concrete masonry *buildings* constructed to NZS 3604 or NZS 4229 in accordance with B1/AS1, pipe trenches which are open for no longer than 48 hours shall be located no closer than distance 'V' (see Figure 14) to the underside of any *building* foundation. Where the trench is to remain open for periods longer than 48 hours, the minimum horizontal separation shall increase to 3V in all ground except rock.

Amend 9  
Feb 2014

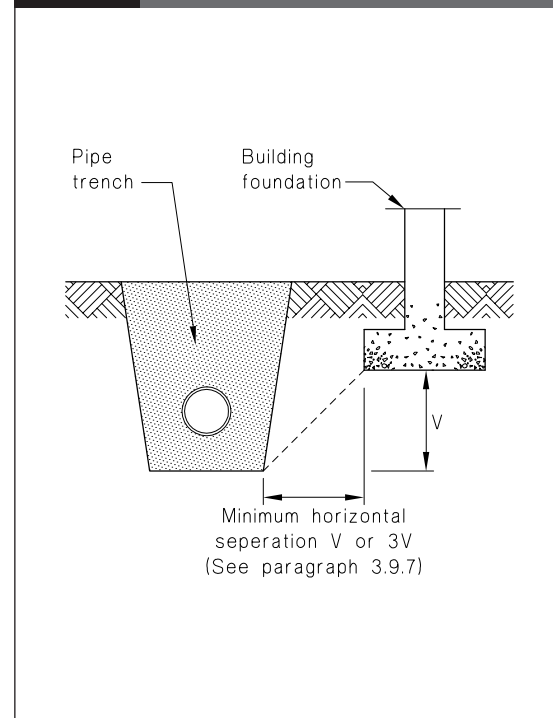
**3.9.8** AS/NZS 2032, AS/NZS 2566.1 and AS/NZS 2566.2 provide other acceptable solutions.

Amend 7  
Sep 2010

**COMMENT:**

These provisions may exceed New Zealand Building Code minimum requirements.

**Figure 14:** Relationship of Pipe Trench to Building Foundation  
Paragraph 3.9.7



Amend 1  
Sep 1993

**4.0 Downpipes**

**4.1 Materials**

**4.1.1** Materials for downpipes shall comply with Table 4.

**Table 4: Acceptable Material Standards for Downpipes**  
Paragraph 4.1.1

PVC-U pipe	AS/NZS 1260 or AS/NZS 1254
Galvanised steel sheet	AS 1397
Copper sheet	BS EN 1172 or AS 1566
Copper pipe	NZS 3501 or AS 1432
Aluminium sheet	AS/NZS 1734
Aluminium pipe	AS 1866
Stainless steel sheet	ASTM A240M
Stainless steel pipe	AS 1528
Zinc aluminium sheet	AS 1397
Polyethylene pipe	AS/NZS 4130

Amends 1&2

Amend 8 Oct 2011

Amend 7 Sep 2010

Amend 7 Sep 2010

Amend 7 Sep 2010

Amend 12 Nov 2023

**4.1.2** Downpipes, gutters, roofing, fastenings and all adjoining components shall be of the same or a compatible material to eliminate the risk of galvanic corrosion.

**4.2 Sizing of downpipes**

**4.2.1** Downpipes sized using Table 5 are acceptable. Other downpipes are acceptable provided their cross-sectional area is no less than that required by Table 5, and they permit passage of a 50 mm diameter sphere.

**4.3 Installation of downpipes**

**4.3.1** Where thermal movement of downpipes cannot be accommodated by movement of the guttering, expansion joints shall be incorporated.

**4.3.2** All internal downpipes shall withstand without leakage, a water test with an applied head of 1.5 m of water, or a high pressure air test as described in E1/MM1 Paragraph 8.3.

Amend 5 Jul 2001

**5.0 Roof Gutters**

**5.1 Size of roof gutters**

**5.1.1** Roof gutters shall discharge to downpipes that are sized as given in Paragraph 4.2.

**5.1.2** Any gutter under consideration shall be divided into sections and each section shall be sized. A section shall comprise the length of gutter between a downpipe and the adjacent high point on one side only of that downpipe. Each section of gutter shall have a cross-sectional area of no less than that determined from Figure 15 or Figure 16 (depending on whether the gutter is external or internal), and increased where required in accordance with Paragraph 5.1.3.

**5.1.3** Figures 15 and 16 are based on a rainfall intensity "I" of 100 mm/hr. Where "I" exceeds 100 mm/hr the required gutter size shall be increased by taking the value read from the figures and multiplying it by the ratio of "I"/100. Paragraph 3.2.2 describes how to determine the value of "I".

Amend 2 Aug 1994

Amend 2 Aug 1994

Amend 1 Sep 1993

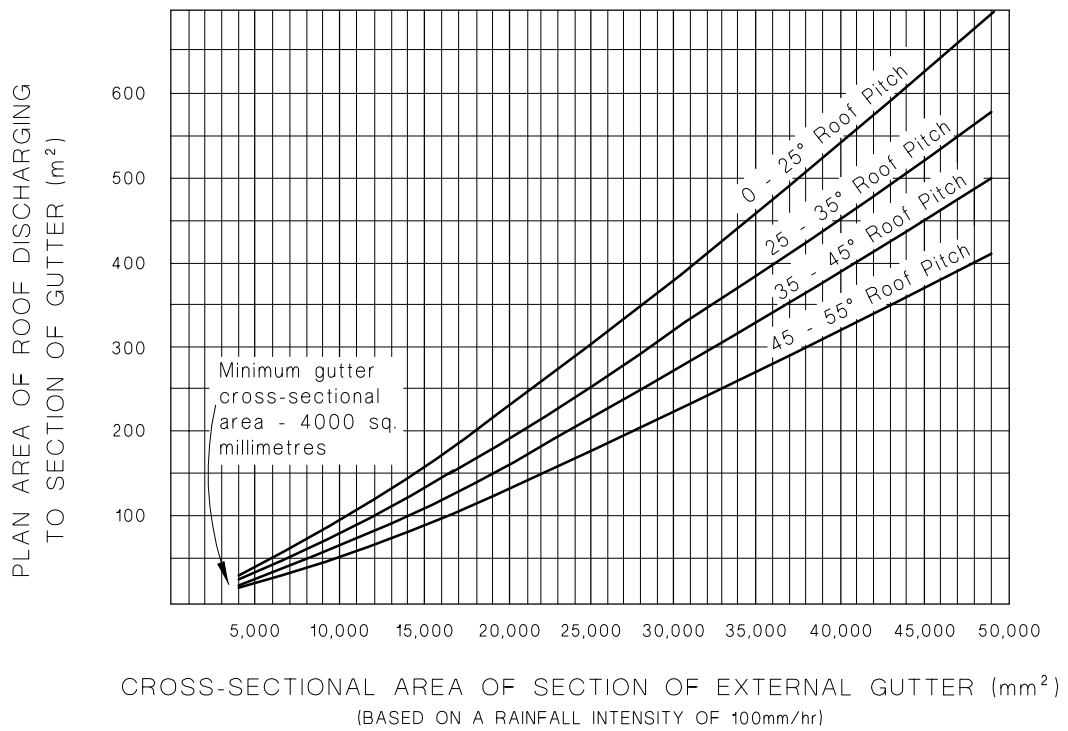
**Table 5: Downpipe Sizes for Given Roof Pitch and Area**  
Paragraph 4.2.1

Downpipe size (mm) (minimum internal sizes)	Roof pitch			
	0-25°	25-35°	35-45°	45-55°
<b>Plan area of roof served by the downpipe (m<sup>2</sup>)</b>				
63 mm diameter	60	50	40	35
74 mm diameter	85	70	60	50
100 mm diameter	155	130	110	90
150 mm diameter	350	290	250	200
65 x 50 rectangular	60	50	40	35
100 x 50 rectangular	100	80	70	60
75 x 75 rectangular	110	90	80	65
100 x 75 rectangular	150	120	105	90

Amend 1 Sep 1993

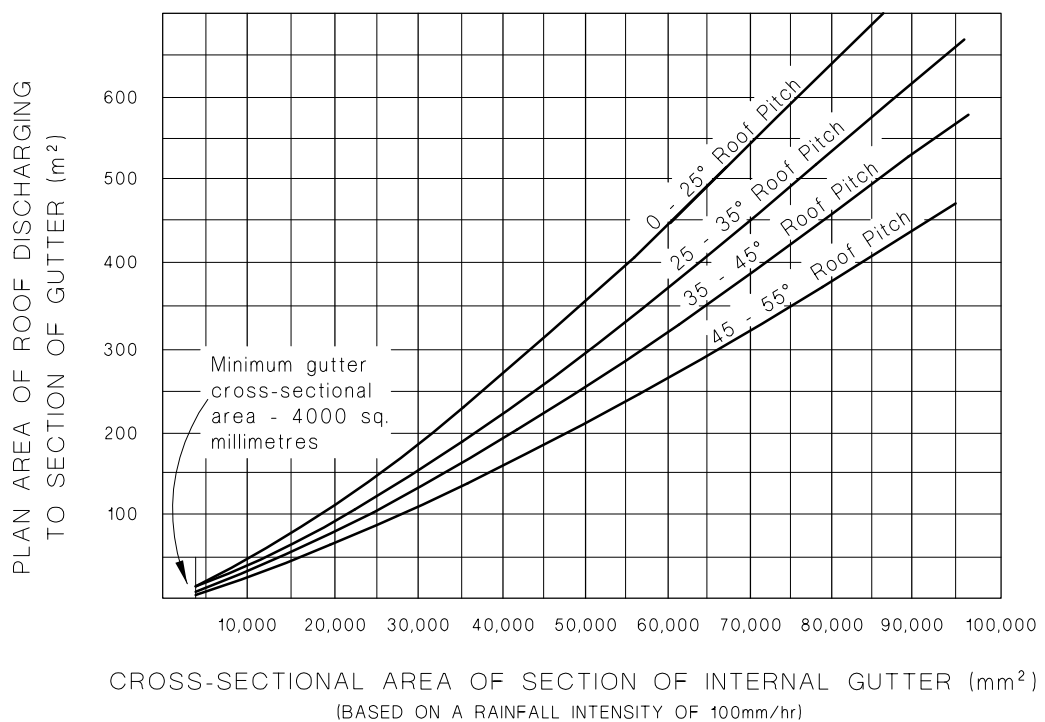
Amend 2 Aug 1994

**Figure 15: Cross-sectional Area of External Gutter**  
 Paragraphs 5.1.2 and 5.1.3



Amend 1  
 Sep 1993

**Figure 16: Cross-sectional Area of Internal Gutter**  
 Paragraphs 5.1.2 and 5.1.3



Erratum 1  
 Sep 2010  
 Amend 1  
 Sep 1993



Amend 1  
Sep 1993

**5.1.4** In no case shall the cross-sectional area of any gutter be less than 4000 mm<sup>2</sup>.

**5.1.5** Internal gutters shall be constructed with:

- a) A minimum width of 300 mm, and
- b) Freeboard allowance of at least 30 mm greater depth than that determined from Figure 16 in situations where overtopping could enter a *building*.

**COMMENT:**

Refer to Acceptable Solution E2/AS1 for the design of valley gutters.

Amend 11  
Nov 2020

**5.2 Materials**

**5.2.1** Roof gutter materials shall comply with the standards stated in Table 6.

**COMMENT:**

Proprietary membrane systems using bitumen, rubber or epoxy resins may also be acceptable.

**Table 6: Acceptable Material Standards for Roof Gutters**  
Paragraph 5.2.1

PVC-U	AS 1273
Galvanised steel	AS 1397
Copper	BS EN 1172 or AS 1566
Aluminium	AS/NZS 1734
Stainless steel	ASTM A240M
Zinc aluminium	AS 1397

Amends  
2, 11, 12

Amend 12  
Nov 2023

Amend 7  
Sep 2010

**5.3 Gradients**

**5.3.1** Roof gutters shall fall to an outlet.

**5.4 Thermal movement**

**5.4.1** Allowance shall be made for the thermal expansion and contraction of gutters. Table 7 shows for different materials the change in length of 5.0 m of guttering when subjected to a 50°C change in temperature.

**COMMENT:**

The provision of expansion joints is particularly important where both ends of a gutter are restrained against movement, and on PVC-U guttering due to its relatively high rate of thermal expansion.

Amend 7  
Sep 2010

**Table 7: Thermal Expansion of 5 m length over 50°C**  
Paragraph 5.4.1

Material	Expansion (mm)
PVC-U	17.5
Zinc	5.0
Galvanised steel	2.5
Copper	4.5
Aluminium	5.8
Stainless steel	3.8

Amend 7  
Sep 2010

**5.5 Overflow outlets**

**5.5.1** All internal gutters shall be fitted with overflow outlets which drain to the exterior of the *building*. The top of the outlet shall be set at least 50 mm below the top of the gutter. The cross-sectional area of the outlet shall be no less than the cross-sectional area of the downpipes (determined by Paragraph 4.2.1) serving the gutter.

**COMMENT:**

An internal gutter overflow outlet should be located to give an early, conspicuous warning to the *building* occupier that maintenance is required.

**5.5.2** External gutters do not require overflow outlets but shall be installed to ensure any overflow from the gutter spills to the outside of the *building*.

**COMMENT:**

Although specific overflow provision is not necessary it is nevertheless important to ensure any overflowing water cannot track back inside the *building* where it could cause problems.

Amend 9  
Feb 2014



# E1/AS1 Appendix A Rainfall Intensities

**Table A: Rainfall Intensities**  
10 minute duration rainfall intensities for various locations in New Zealand

Location	Latitude degrees	Longitude degrees	10% AEP intensity mm/hr	2% AEP intensity mm/hr
<b>NORTHLAND</b>				
Taipa Bay-Mangōnui	-35	173.5	86	117
Awanui	-35.05	173.25	85	116
Kaeo	-35.1	173.78	91	123
Kaitaia	-35.11	173.26	86	117
Ahipara	-35.17	173.17	86	116
Kerikeri	-35.23	173.95	101	135
Russell	-35.27	174.12	109	147
Paihia	-35.29	174.09	110	148
Ōkaihau	-35.32	173.77	97	130
Ōhaeawai	-35.35	173.88	99	132
Moerewa	-35.38	174.02	108	144
Kawakawa	-35.38	174.07	110	147
Rawene	-35.4	173.5	85	114
Kaikohe	-35.41	173.81	94	125
Ōmāpere and Opononi	-35.51	173.4	85	114
Whangārei	-35.72	174.3	103	140
Maungatāpere	-35.75	174.2	101	137
Dargaville	-35.95	173.87	82	110
Te Kōpuru	-36.03	173.92	83	112
Mangawhai Heads	-36.05	174.59	94	130
Kaiwaka	-36.1	174.39	90	123
Maungaturoto	-36.12	174.35	89	121
Ruawai	-36.13	174.03	83	112
<b>AUCKLAND</b>				
Leigh	-36.19	174.63	95	130
Snells Beach	-36.21	174.69	93	127
Algies Bay-Mahurangi	-36.26	174.76	92	124
Wellsford	-36.3	174.52	100	135
Parakai	-36.38	174.45	95	128
Warkworth	-36.4	174.66	99	134
Muriwai Beach	-36.52	174.69	98	129
Helensville	-36.68	174.45	95	125
North Shore	-36.81	174.79	98	129
Waiheke Island	-36.81	175.12	102	137
Auckland	-36.87	174.77	97	127
Waitākere	-36.91	174.69	97	128
Manukau	-36.97	174.82	93	121
Bombay	-37.05	174.95	97	129
Pukekohe	-37.2	174.9	97	131
Waiuku	-37.25	174.73	92	122

Amend 11  
Nov 2020

Amend 11  
Nov 2020**Table A: Rainfall Intensities continued**  
10 minute duration rainfall intensities for various locations in New Zealand

Location	Latitude degrees	Longitude degrees	10% AEP intensity mm/hr	2% AEP intensity mm/hr
<b>WAIKATO</b>				
Coromandel	-36.74	175.5	96	132
Pauanui	-37.02	175.86	97	137
Te Puru-Thornton Bay	-37.04	175.52	91	127
Thames	-37.14	175.53	88	124
Whangamatā	-37.21	175.86	97	137
Ngatea	-37.27	175.5	88	123
Kerepehi	-37.3	175.53	87	121
Meremere	-37.32	175.07	96	132
Paeroa	-37.38	175.67	88	125
Te Kauwhata	-37.4	175.15	92	127
Waihi	-37.4	175.83	107	152
Te Aroha	-37.53	175.7	94	135
Huntly	-37.56	175.16	91	125
Waitoa	-37.6	175.63	90	129
Morrinsville	-37.65	175.53	91	130
Waharoa	-37.75	175.75	89	129
Hamilton	-37.78	175.27	92	129
Raglan	-37.8	174.86	89	121
Matamata	-37.82	175.77	89	129
Cambridge	-37.89	175.45	91	129
Te Awamutu	-38.02	175.32	92	129
Putāruru	-38.05	175.78	85	121
Mamaku	-38.06	176.05	102	143
Otorohanga	-38.18	175.19	94	132
Tokoroa	-38.23	175.84	85	121
Te Kuiti	-38.33	175.17	96	136
Mangakino	-38.38	175.74	75	107
Piopio	-38.47	175.02	95	134
Reporoa	-38.5	176.36	84	121
Taupō	-38.7	176.07	73	107
Tūrangi	-38.99	175.79	71	103
<b>BAY OF PLENTY</b>				
Waihi Beach	-37.4	175.93	99	141
Island View - Pios Beach	-37.46	175.99	95	136
Katikati	-37.56	175.9	93	133
Tauranga	-37.68	176.17	101	145
Maketu	-37.77	176.45	109	156
Te Puke	-37.78	176.33	103	148
Paengaroa	-37.82	176.42	106	152
Te Kaha	-37.82	177.67	96	136
Matatā	-37.89	176.75	116	163

**Table A: Rainfall Intensities continued**  
10 minute duration rainfall intensities for various locations in New Zealand

Location	Latitude degrees	Longitude degrees	10% AEP intensity mm/hr	2% AEP intensity mm/hr
Edgecumbe	-37.97	176.83	112	160
Whakatāne	-37.97	176.99	100	142
Ōpōtiki	-38.01	177.28	102	146
Te Teko	-38.03	176.8	98	139
Tāneatua	-38.07	176.98	95	135
Kawerau	-38.1	176.7	95	136
Rotorua	-38.14	176.26	96	136
Kaingaroa Forest	-38.36	176.68	91	128
Murupara	-38.45	176.7	84	119
<b>GISBORNE</b>				
Ruatoria	-37.9	178.32	80	119
Tokomaru Bay	-38.12	178.3	68	103
Patutahi	-38.38	177.53	59	83
Tolaga Bay	-38.37	178.3	61	93
Manutuke	-38.41	177.55	52	74
Te Karaka	-38.47	177.87	47	73
Gisborne	-38.66	178.02	67	102
<b>MANAWATU-WHANGANUI</b>				
Ōhura	-38.85	174.98	86	124
Taumarunui	-38.88	175.26	84	123
Ohakune	-39.41	175.41	77	111
Raetihi	-39.42	175.27	90	130
Waiouru	-39.47	175.67	62	91
Taihape	-39.68	175.78	65	97
Whanganui	-39.93	175.03	68	100
Hunternville	-39.93	175.57	70	103
Rātana	-40.03	175.17	66	96
Marton	-40.08	175.38	69	101
Halcombe	-40.13	175.48	73	107
Bulls	-40.17	175.38	71	102
Sanson	-40.22	175.42	70	102
Feilding	-40.22	175.57	69	101
Dannevirke	-40.21	176.09	77	119
Rongotea	-40.3	175.42	67	97
Himatangi Beach	-40.32	175.24	66	93
Woodville	-40.33	175.87	66	99
Palmerston North	-40.36	175.62	65	94
Pahiatua	-40.45	175.83	61	91
Foxton	-40.47	175.28	71	100
Tokomaru	-40.47	175.5	68	98
Shannon	-40.55	175.4	70	100
Levin	-40.61	175.27	74	104

Amend 11  
Nov 2020

Amend 11  
Nov 2020**Table A: Rainfall Intensities continued**  
10 minute duration rainfall intensities for various locations in New Zealand

Location	Latitude degrees	Longitude degrees	10% AEP intensity mm/hr	2% AEP intensity mm/hr
Te Horo	-40.63	175.19	76	107
Eketāhuna	-40.65	175.7	73	105
<b>HAWKES BAY</b>				
Tuai	-38.82	177.15	69	98
Frasertown	-38.97	177.4	70	103
Wairoa	-39.04	177.42	82	121
Nūhaka	-39.03	177.75	84	126
Napier	-39.5	176.89	69	105
Hastings	-39.64	176.83	62	95
Ōtāne	-39.9	176.62	69	106
Waipawa	-39.95	176.57	67	104
Waipukurau	-40	176.56	65	100
Takapau	-40.03	176.35	72	113
<b>TARANAKI</b>				
Waitara	-39	174.23	98	136
Urenui	-39	174.38	95	133
New Plymouth	-39.05	174.07	100	138
Egmont Village	-39.14	174.12	114	158
Inglewood	-39.15	174.2	117	163
Ōkato	-39.2	173.88	111	153
Rahotu	-39.28	173.78	99	137
Stratford	-39.35	174.27	99	138
Kaponga	-39.43	174.15	94	132
Eltham	-39.43	174.3	97	137
Ōpunake	-39.46	173.84	87	121
Manaia	-39.55	174.12	83	117
Hāwera	-39.59	174.28	84	119
Pātea	-39.75	174.47	79	112
Waverley	-39.77	174.63	80	115
<b>TASMAN</b>				
Tākaka	-40.85	172.8	78	108
Riwaka	-41.05	173	77	108
Motueka	-41.11	173.02	68	94
Brightwater	-41.38	173.1	80	115
Wakefield	-41.4	173.05	81	117
Murchison	-41.8	172.33	56	85
<b>WELLINGTON</b>				
Ōtaki	-40.75	175.13	82	114
Kapiti	-40.94	174.99	75	103
Masterton	-40.95	175.67	54	80
Carterton	-41.02	175.52	57	83
Greytown	-41.08	175.45	57	82

**Table A: Rainfall Intensities continued**  
10 minute duration rainfall intensities for various locations in New Zealand

Location	Latitude degrees	Longitude degrees	10% AEP intensity mm/hr	2% AEP intensity mm/hr
Upper Hutt	-41.12	175.07	72	99
Featherston	-41.12	175.32	63	88
Porirua	-41.13	174.83	76	105
Mākara-Ohariu	-41.2	174.75	74	102
Lower Hutt	-41.21	174.91	72	100
Martinborough	-41.22	175.44	54	77
Wellington	-41.28	174.77	70	97
<b>WEST COAST</b>				
Hector-Ngakawau	-41.63	171.87	84	122
Westport	-41.75	171.58	101	145
Reefton	-42.11	171.87	71	103
Blackball	-42.3	171.49	92	132
Dobson	-42.39	171.44	93	133
Greymouth	-42.45	171.21	95	133
Hokitika	-42.72	170.97	104	144
Ross	-42.9	170.82	110	149
Franz Josef/Waiiau	-43.38	170.17	92	124
Fox Glacier	-43.42	170.05	99	133
<b>NELSON</b>				
Nelson	-41.27	173.3	77	107
<b>MARLBOROUGH</b>				
Havelock	-41.28	173.77	70	98
Picton	-41.3	174.01	59	83
Blenheim	-41.52	173.95	48	69
Seddon	-41.67	174.07	49	70
<b>CANTERBURY</b>				
Kaikōura	-42.4	173.69	53	79
Hanmer Springs	-42.52	172.83	46	72
Culverden	-42.77	172.85	43	67
Cheviot	-42.81	173.26	45	70
Amberley	-43.15	172.72	42	65
Rangiora	-43.3	172.6	46	71
Oxford	-43.3	172.18	60	93
Woodend	-43.32	172.67	42	65
Cust	-43.32	172.37	53	84
Darfield	-43.48	172.12	47	75
Christchurch	-43.53	172.62	39	62
Rolleston	-43.58	172.38	48	77
Lyttelton	-43.60	172.72	26	41
Burnham Military Camp	-43.61	172.32	47	75
Lincoln	-43.63	172.48	51	82
Methven	-43.63	171.63	54	83

Amend 11  
Nov 2020

**Table A: Rainfall Intensities continued**  
10 minute duration rainfall intensities for various locations in New Zealand

Location	Latitude degrees	Longitude degrees	10% AEP intensity mm/hr	2% AEP intensity mm/hr
Dunsandel	-43.67	172.2	46	74
Tai Tapu	-43.68	172.54	41	65
Aoraki/Mount Cook	-43.66	170.17	72	102
Rakaia	-43.75	172.02	48	76
Leeston	-43.77	172.3	47	75
Akaroa	-43.81	172.97	45	69
Southbridge	-43.82	172.25	46	72
Ashburton	-43.88	171.76	52	80
Lake Tekapo	-44	170.5	33	53
Geraldine	-44.1	171.23	48	75
Fairlie	-44.1	170.83	55	86
Temuka	-44.23	171.27	44	71
Pleasant Point	-44.27	171.13	47	75
Twizel	-44.25	170.1	37	58
Timaru	-44.4	171.26	46	73
Pareora	-44.47	171.22	48	77
Omarama	-44.48	169.97	35	57
Otematata	-44.6	170.18	38	61
Waimate	-44.74	171.06	42	65
Kurow	-44.73	170.47	42	65
<b>OTAGO</b>				
Wanaka	-44.7	169.13	26	40
Arrowtown	-44.93	168.83	32	50
Oamaru	-45.09	170.98	42	65
Cromwell	-45.05	169.2	36	59
Queenstown	-45.04	168.65	34	53
Ranfurly	-45.12	170.1	52	85
Kakanui	-45.18	170.9	42	65
Clyde	-45.18	169.32	45	75
Alexandra	-45.25	169.38	44	73
Hampden	-45.33	170.82	43	67
Palmerston	-45.48	170.72	45	71
Roxburgh	-45.53	169.32	53	90
Waikouaiti	-45.6	170.68	44	69
Karitane	-45.63	170.65	44	70
Warrington	-45.72	170.59	43	68
Waitati	-45.75	170.57	43	69
Outram	-45.87	170.23	51	81
Dunedin	-45.89	170.5	47	73
Lawrence	-45.92	169.68	54	87
Tapanui	-45.95	169.27	54	90

**Table A: Rainfall Intensities continued**  
10 minute duration rainfall intensities for various locations in New Zealand

Location	Latitude degrees	Longitude degrees	10% AEP intensity mm/hr	2% AEP intensity mm/hr
Milton	-46.12	169.97	56	88
Clinton	-46.2	169.38	53	86
Balclutha	-46.23	169.73	55	87
Stirling	-46.25	169.78	54	85
Kaitangata	-46.28	169.85	54	85
Owaka	-46.45	169.65	49	77
<b>OTAGO</b>				
Te Anau	-45.42	167.72	48	75
Manapouri	-45.57	167.62	51	78
Lumsden	-45.73	168.43	52	87
Riversdale	-45.9	168.73	50	84
Ohai	-45.93	167.95	50	80
Gore	-46.1	168.93	57	95
Winton	-46.15	168.32	47	76
Tuatapere	-46.13	167.68	45	71
Otautau	-46.15	168	46	74
Edendale	-46.32	168.78	48	80
Wyndham	-46.33	168.85	49	82
Riverton/Aparima	-46.36	168	49	77
Invercargill	-46.41	168.32	54	87
Bluff	-46.49	168.29	51	81

**Notes:**

This table is based on information produced by the National Institute for Water and Atmospheric Research (NIWA) in December 2019, and the rainfall intensities are based on historical rain gauge data.

Rainfall intensity data is also available online in digital form from the National Institute for Water and Atmospheric Research (NIWA) High Intensity Rainfall Design System (HIRDS).

HIRDS provides rainfall intensity estimates for any location in New Zealand based on historical rain gauge data and projections of future rainfall intensities for various climate change scenarios.

Amend 11  
Nov 2020

# Acceptable Solution E1/AS2

(Included in Amendment 11)

## 1.0 AS/NZS 3500.3 Stormwater drainage

**1.0.1** AS/NZS 3500.3, as modified by Paragraph 1.0.4, is an Acceptable Solution for the design and installation of *surface water* drainage systems.

### COMMENT:

Comparable terminology	
AS/NZS 3500.3	E1/AS1
Eaves gutter	External gutter
Box gutter	Internal gutter
Inlet pit	Surface water sump
Stormwater pit	Access/Inspection chamber

**1.0.2** This Acceptable Solution is limited to *buildings* and *sitework* where *surface water* results only from rainfall, and which are:

- Free from a history of flooding,
- Not adjacent to a watercourse,
- Not located in low lying area, and
- Not located in a secondary flow path.

**1.0.3** *Buildings* to which this Acceptable Solution is applied shall comply with the requirements of Acceptable Solution E1/AS1 Section 2.0 Minimum Acceptable Floor Level.

**1.0.4** Modifications to AS/NZS 3500.3

**Clause 3.6** Delete and replace with:

"Refer to NZBC Acceptable Solution E2/AS1 for the design of valley gutters."

**Clause 4.5.6** Insert:

"(f) *Connections to drains* Downpipes shall discharge directly into a site stormwater drain, and should not discharge via an inlet pit."

**Clause 5.4.5 (b)** Insert:

NOTE 3 Where there are differences between the design rainfall intensities obtained using sources (i) and (ii) for a particular location, the most conservative rainfall intensity should be used for design calculations.

**Clause 6.2.3** Insert:

"Alternatively, trenches shall be no less than 300 mm wide for pipes DN 100 or smaller."

**Clause 6.3.1.1 (d)** Delete and replace with:

- "(d) using 45°, sweep or oblique junctions; and  
(e) with changes in direction not exceeding 90° at any point."

**Clause 6.4 Subsoil drains** Insert:

"In New Zealand, this Clause is informative only."

**Clause 6.4.1 NOTES** Insert:

- "4 Subsoil drains should discharge to the site stormwater drainage system via an inlet pit or silt arrester.  
5 Subsoil drains should be laid at grade with a uniform fall of not less than 1:300."

**Clause 7.4.1** Delete and replace with:

**"7.4.1 Location**

For other than single dwellings, inspection openings for the maintenance of site stormwater drains shall be installed at —

- each point of connection;
- even spacings not more than 30 m apart;
- each end of any inclined jump-up that exceeds 6 m in length;
- each connection to an existing site stormwater drain; and
- at any change of direction greater than 45°.

NOTES:

- Inspection openings may be replaced by a stormwater pit.

Amend 12  
Nov 2023

Amend 12  
Nov 2023

Amend 12  
Nov 2023

Amend 12  
Nov 2023

Amend 12  
Nov 2023

Amend 12  
Nov 2023



- 2 No inspection opening is needed at a connection to a site stormwater drain where the branch drain serves only a single external downpipe or an inlet pit."

**Clause 7.4.3** Delete and replace with:

**"7.4.3 Access**

Access to below-ground inspection openings shall be either by—

- (a) a stormwater pit,
- (b) a sealed riser terminated at ground level or floor level in an accessible position; or
- (c) a removable cap at drain level for drains of DN 150 or smaller.

NOTE: Options (a) or (b) are preferred in landscaped or sealed areas, or where the depth of an inspection opening would be greater than 1000 mm below finished ground level."

**Clause 7.5.1.1 (b)** Delete.

**Clause 7.5.1.2** Delete and replace with:

**"7.5.1.2 Inlet pits**

Inlet pits shall be installed —

- (a) to allow the collection and ingress of surface water to a site stormwater drain,
- (b) with sufficient capacity at the bottom for the settlement of silt and debris, and
- (c) with a submerged (or trapped) outlet which prevents floatable solids entering the site stormwater drain.

NOTES:

1. Inlet pits should not receive discharge from stormwater drains.
2. Refer to NZBC Acceptable Solution E1/AS1 Figure 8 and Figure 9 for examples of surface water sumps (inlet pits) which incorporate submerged outlets and provide sufficient capacity for the settlement of silt and debris."

**Clause 7.7.1 (a)** Delete and replace with:

"(a) a 45° junction, a sweep junction or an oblique junction at an upstream angle not greater than 60°, as shown in Figure 7.7.1(A);"

**Clause 7.10 On-Site Stormwater Detention (OSD) Systems** Insert:

"In New Zealand, this Clause is informative only."

**Section 8 Pumped Systems** Insert:

"In New Zealand, this Section is informative only."

**Section 10 Siphonic Drainage Systems**

Insert: "In New Zealand, this Section is informative only."

**Appendix C – C.2.2 New Zealand** Delete and replace with:

"The procedure for the determination of rainfall intensities, in mm/hr, for the site considered is as follows:

- (a) Use the applicable rainfall intensity values provided by the local territorial authority, or
- (b) Use the applicable rainfall intensity values listed in Table E.1, or
- (c) Use the applicable rainfall intensity values provided by the National Institute for Water and Atmospheric Research (NIWA) High Intensity Rainfall Design System (HIRDS).

NOTES:

- 1 Where there are differences between the design rainfall intensities obtained using sources (a), (b) and (c) for a particular location, the most conservative rainfall intensity should be used for design calculations.
- 2 Territorial Authorities may refer to any available Regional Council rainfall data to establish design rainfall intensities for their city or district."

Amend 12  
Nov 2023

# Index E1/VM1 & AS1/AS2

(Revised by Amendment 4)

All references to Verification Methods and Acceptable Solutions are preceded by **VM** or **AS** respectively.

<b>Building site</b> .....	<b>VM1</b> 3.2.2, 4.0.1, 4.1.10, <b>AS1</b> 1.0.1
evaluation .....	<b>VM1</b> 1.0.3
<b>Buildings</b> .....	<b>AS1</b> 1.0.1
minimum floor level .....	<b>AS1</b> 2.0, Figures 1 and 2
<b>Catchment</b>	
characteristics .....	<b>VM1</b> 1.0.2, 2.0.1, 2.1, 2.3, 4.2.1
<b>Downpipes</b> .....	<b>AS1</b> 3.4.2 b), 3.7.8, 4.0, 5.1.1
installation .....	<b>AS1</b> 4.3
materials .....	<b>AS1</b> 4.1, Table 4
sizing .....	<b>AS1</b> 4.2, Table 5
<b>Drainage</b>	
access points .....	<b>AS1</b> 3.7, 3.7.3, 3.7.7, 3.7.8
access chambers .....	<b>VM1</b> 5.0.1, <b>AS1</b> 3.7.1, 3.7.2 b), 3.7.4, 3.7.5, Figure 12
inspection chambers .....	<b>AS1</b> 3.7.1, 3.7.2 b), 3.7.4, 3.7.5, Figure 11
inspection points .....	<b>AS1</b> 3.7.1, 3.7.2 b)
rodding points .....	<b>AS1</b> 3.7.1, 3.7.2 a), Figure 10
alignment .....	<b>AS1</b> 3.3, 3.7.3 a), Figures 4 and 5
bedding and backfilling .....	<b>AS1</b> 3.9, 3.9.2, Figure 13
other Acceptable Solutions .....	<b>AS1</b> 3.9.8
materials .....	<b>AS1</b> 3.9.5
placing and compacting .....	<b>AS1</b> 3.9.6
proximity to buildings .....	<b>AS1</b> 3.9.7, Figure 14
trench slope .....	<b>AS1</b> 3.9.3
trench width .....	<b>AS1</b> 3.9.4
bubble-up chamber system .....	<b>AS1</b> 3.4.2, Figures 6 and 7
downstream water systems .....	<b>VM1</b> 4.3
drains under buildings .....	<b>AS1</b> 3.7.6, 3.7.7, 3.7.8
gradient .....	<b>AS1</b> 3.3.1, 3.7.3 b)
minimum gradient .....	<b>AS1</b> 3.4, Table 2
joints .....	<b>AS1</b> 3.5, Table 3
leakage tests .....	<b>VM1</b> 8.0, <b>AS1</b> 3.8
high pressure air test .....	<b>VM1</b> 8.3
low pressure air test .....	<b>VM1</b> 8.2
water test .....	<b>VM1</b> 8.1
materials .....	<b>AS1</b> 3.1, Table 1
open water, upstream of site .....	<b>VM1</b> 4.2
piped water, upstream of site .....	<b>VM1</b> 4.1
quantity .....	<b>VM1</b> 4.1.10
tailwater depth .....	<b>VM1</b> 4.1.6, 4.1.7

Amend 7  
Sep 2010

Drainage (*continued*)

secondary flow . . . . . **VM1** 4.0, **AS1** 1.0.1 d)  
 downstream drainage . . . . . **VM1** 4.3  
 flow . . . . . **VM1** 4.1.11  
 headwater depth . . . . . **VM1** 4.1.4, 4.1.5, 4.1.8,  
 4.1.9, Figures 5, 6, 7, 10 and 11  
 site – outfall protection . . . . . **VM1** 7.0  
 sizing . . . . . **VM1** 3.0, **AS1** 3.2, Figure 3  
 energy losses . . . . . **VM1** 5.0  
 hydraulic design of drains . . . . . **VM1** 1.0.4, 3.2, Figures 6 and 7  
 air entrainment . . . . . **VM1** 3.2.4  
 headwater depth . . . . . **VM1** 3.2.2, Figure 5 a)  
 minimum size . . . . . **VM1** 3.1  
 minimum velocity . . . . . **VM1** 6.0  
 pipe size decrease . . . . . **VM1** 5.0.2  
 soak pits . . . . . **VM1** 9.0, Figure 13  
 stormwater . . . . . **AS2** 1.0  
 sumps . . . . . **AS1** 3.6.1, 3.6.2, Figures 8 and 9  
 surface water inlets . . . . . **AS1** 3.6  
 upstream water systems . . . . . **VM1** 4.1, 4.2

Amend 11  
 Nov 2020

**Flooding**

flood risk assessment . . . . . **VM1** 3.2.2  
 historical information . . . . . **AS1** 1.0.1  
 protection from . . . . . **VM1** 3.2.2

**Gutters**

gradients . . . . . **AS1** 5.0  
 materials . . . . . **AS1** 5.3  
 overflow outlets . . . . . **AS1** 5.5  
 sizing . . . . . **AS1** 5.1, Figures 15 and 16  
 thermal movement . . . . . **AS1** 5.4, Table 7

**Run-off**

estimation of run-off . . . . . **VM1** 2.0  
 Rational Method . . . . . **VM1** 2.0.1  
 rainfall intensity . . . . . **VM1** 2.2, **AS1** Appendix A  
 run-off coefficient . . . . . **VM1** 2.1, Table 1  
 slope correction . . . . . **VM1** 2.1.3, Table 2  
 time of concentration . . . . . **VM1** 2.2.1, 2.3  
 alternative procedure . . . . . **VM1** 2.3.6, 2.3.7  
 catchment slopes . . . . . **VM1** 2.3.7  
 open channel flow . . . . . **VM1** 2.3.5  
 pipe flow . . . . . **VM1** 2.3.4, Table 1  
 time of entry . . . . . **VM1** 2.3.2  
 overland flow . . . . . **VM1** 2.3.2 b), Figure 1  
 road channel flow . . . . . **VM1** 2.3.2 b), Figure 2  
 time of network flow . . . . . **VM1** 2.3.3